

# A3FE BLUE BIRD ALL AMERICAN A3RE

2013

DRIVERS HANDBOOK

COUNT ON BLUE BIRD



BLUE BIRD







# **ALL AMERICAN**

10026202  
Edition A

© 2011 Blue Bird Corporation. All rights reserved.

All Blue Bird products sold for use in the United States of America and its insular areas comply with all applicable Federal Motor Vehicle Safety Standards (FMVSS) and applicable Federal ADA requirements.

Many of the components of Blue Bird buses are obtained from outside suppliers. Where maintenance and/or service information conflicts with the component manufacturer's documentation, the manufacturer's documentation prevails.

In the event of any conflict between the requirements of this publication and any applicable legal requirement, the legal requirement prevails. Technical requirements that exceed the legal requirements are not considered to conflict.

Blue Bird Corporation continually endeavors to improve its products and reserves the right to change specifications without notice and without incurring obligation. Text, illustrations, photographs, and specifications in this manual are based on information available at the time of printing. Some equipment and features shown may be optional.



# CONTENTS

## **INTRODUCTION**

- About This Manual / 7
- Reporting Safety Defects / 8
- Noise Emissions / 8
- About 2010 Emission Standards / 9
- Regarding Modifications / 10
- Before Placing the Bus in Service / 12

## **ORIENTATION**

- Vehicle Identification / 13

## **ENTRANCE AND EXIT**

- Outward Opening Door / 14
- Outward Opening (Air Door) / 14
- Power Jackknife Doors / 14
- Emergency Pneumatic Power Door Release / 14
- Electric Outward Opening Door / 15
- Emergency Electric Power Door Release / 15
- Security Lock (Outward Opening Door) / 15
- Jackknife Door Security Lock / 16
- Emergency Door Vandal Lock / 16
- Wheelchair Lifts / 17

## **DRIVER'S AREA**

- Driver's Compartment / 18
- Dash And Instrument Panel / 19
- Warning Bank / 20
- Switch Panel / 21
- Mirror And Adjustment / 22

## **SEATING**

- Standard Driver's Seat / 24
- Premium Driver's Seat / 24
- Driver's Seat Belt With Shoulder Harness / 25
- Passenger Seat Belts (Optional) / 25
- Child Restraint Seats / 26

## **COMPARTMENTS & ACCESS PANELS**

- All American Front Engine / 28
- All American Rear Engine / 28
- Engine Access; All American Front Engine / 29
- Engine Access; All American Rear Engine / 29
- Rear Side Engine Compartment Doors / 29
- Additional Access Panels / 30

## **ENROUTE EMERGENCIES**

### **EMERGENCY EXITS**

- Transpec™ Safety Vent / 32

### **EMERGENCY EQUIPMENT**

- Fire Extinguisher / 34
- First Aid Kit / 34
- Body Fluid Cleanup Kit / 34
- Fire Axe/Crowbar / 34
- Flare Kit / 35
- Triangular Warning Devices / 35

### **TIRE / WHEEL EMERGENCIES**

- Spare Tire Location And Removal / 36
- Damaged Tires / 37
- Wheel And Rim Safety / 38
- Jacking Instructions / 39
- Changing a Flat Tire / 40
- Schrader Valve / 41
- Releasing Spring Brake Manually / 41
- Towing Or Pushing / 42

## **ROUTINE OPERATION**

### **PRE-ROUTE INSPECTION**

Weekly Inspection / 45

### **ENGINE OPERATION**

Engine Exhaust Caution (Carbon Monoxide) / 46

Diesel Fuel / 46

Diesel Engine Starting Procedure / 47

Starting With Boost Cables / 47

Using The Engine As A Brake / 48

Engine Warning System / 48

Exhaust System / 49

DPF Regeneration In Blue Bird Buses / 50

Levels of Notification / 51

Stationary Regeneration Precautions / 54

SCR System in Blue Bird Buses / 55

### **COMPRESSED NATURAL GAS**

Owner / Operator Responsibilities / 61

National Fire Protection / 61

Fuel System Description / 62

Safety Cautions And Warnings / 63

Compressed Natural Gas Fuel / 65

Compressed Natural Gas Filters / 65

Refueling / 66

Specific Gravity / 67

Fuel Toxicity And Safety / 67

Flammability / 67

Antiknock Properties / 68

Energy Conversions / 68

Vehicle Performance And Emissions / 68

Starting Procedure / 68

Cold Start / 69

Operation And Maintenance Of CNG Vehicle Components / 69

## **TRANSMISSIONS**

Allison Automatic Transmission / 70

Allison Model 3000 Series Transmission / 70

Allison Model 2000 Series Transmission / 72

Range Inhibited Light / 73

Check Transmission Light / 73

Allison Automatic Transmission Driving Tips / 74

Transmission Indicators / 75

Transmission Service Prognostics / 76

Hydraulic Retarder (If Equipped) / 77

## **BRAKING**

Antilock Braking System (ABS) / 78

Hydraulic Brakes / 78

Air Brakes / 81

## **HEATERS**

Heater Operation / 82

Control Panel Outlet Locations / 82

Defrosting / 83

Heater Defroster Location / 83

Driver / Passenger Comfort / 83

Temperature Control / 83

Standard Heater Cut Off Valves / 84

## **CARE & MAINTENANCE**

### **ELECTRICAL**

- Interior Lights / 88
- Exterior Lights / 88
- Doran Warning Light Monitor / 89
- Circuit Breakers / 91

### **DOOR ADJUSTMENT & LUBRICATION**

- Outward Opening Door Adjustment / 92
- Outward Opening (Air Powered) Adjustment / 92
- Jackknife Door Adjustment / 93
- Power Jackknife Door Adjustment / 94
- Sliding Bolt Vandal Lock / 94
- Security Lock Lubrication (Outward Opening Door) / 95
- Access Doors / 95

### **SEATING CARE**

- Seat Belt Inspection And Maintenance / 96
- Seat Inspection And Maintenance / 96

### **SIGNS & SIGNALS**

- Stop Arms / 100
- Destination Signs / 101

### **ENGINE & RUNNING GEAR**

- Air Intake System Inspection / 102
- Engine Cooling System / 103
- Shutters / 105
- Transmission / 106
- Rear Axle / 107
- Hydraulic Brakes / 107

### **WINDSHIELD WIPERS**

- Washer Solution Reservoir / 108
- Wiper Assembly Replacement / 108
- Wiper Refill Replacement / 108

### **CLEANING**

- Exterior Cleaning / 109
- Floor Cleaning / 111

### **HEATER CARE**

- Annual Maintenance / 112
- Cleaning Auxiliary Fans / 113

### **MAINTENANCE SCHEDULE**

- Maintenance Task Schedule, A3FE / 114
- Maintenance Task Schedule, A3RE / 127
- Maintenance Locations / 140
- General Data / 141





# INTRODUCTION

*Thank you for selecting the Blue Bird All American. The All American is the culmination of almost a century of Blue Bird heritage in student and public transportation which began in 1927. As always, the design and construction of the All American reflects Blue Bird's concern for safety, efficiency, and quality.*

## **About This Manual**

This Drivers Handbook has been prepared to acquaint you with the operation of the Blue Bird All American, and should be read by all Drivers before operating the unit. Familiarity with automotive operation and control is assumed to be common knowledge to all who will be operating this bus. This book does not address all driving situations which may arise, and it is not a substitute for proper driver training. It will, however, enable a School Bus driver to more quickly feel at home in this model All American.

Your Blue Bird All American may not have all of the equipment described in this manual. You may find information on optional equipment not installed on your bus. You are encouraged to contact your Blue Bird Dealer if additional information or assistance is needed.

For use as a convenient reference, this Handbook also contains some general maintenance information. Although the Driver will not likely be performing service procedures, this information nonetheless serves to further familiarize the Driver with the bus. The maintenance information contained herein is provided as a reference for systems and components that require periodic service. The intervals given are component manufacturers' recommendations and should be considered maximum intervals; that is, the very minimum maintenance schedules that will afford reasonable care of this vehicle. Service technicians should refer to the Service Manual for more complete service information. If this manual does not address your specific questions or concerns, please contact your Blue Bird Dealer. The Dealer will answer your questions or put you in contact with the proper factory personnel.

Throughout this manual are precautions labeled Warnings and Cautions, and set in the style shown here:

**WARNING** *The Warning designation is generally used for precautions which, if not properly observed while performing the related procedures or handling materials, could result in serious personal injury or death.*

**CAUTION** *The Caution designation is generally used for precautions which, if not properly observed while performing the related procedures or handling materials, could result in damage to the bus or its equipment.*

For the terms of the Limited Warranty of this Blue Bird product, refer to the Warranty certificate provided in the owner's documents that came with the vehicle.

This manual provides you with the most current operation information available. We welcome your comments and suggestions regarding this manual. Please direct all correspondence to:

*Blue Bird Corporation  
Attn: TECHNICAL PUBLICATIONS  
P.O. Box 937  
Fort Valley, GA 31030*

### Reporting Safety Defects

If you believe that your vehicle has a defect which could cause a crash or could cause injury or death, you should immediately inform the National Highway Traffic Safety Administration (NHTSA) in addition to notifying Blue Bird.

If NHTSA receives similar complaints, it may open an investigation and, if it finds that a safety defect exists in a group of vehicles, it may order a recall and remedy campaign. However, NHTSA cannot become involved in individual problems between you, your dealer, or Blue Bird Corporation.

To contact NHTSA, you may call the Vehicle Safety Hotline toll-free at:

**1-888-327-4236 (TTY: 1-800-424-9153)**

or go to:

***<http://www.safercar.gov>***

or write to:

***Administrator, NHTSA,***

***400 Seventh***

***Street, SW, Washington, DC 20590***

You can also obtain other information about motor vehicle safety from:

***<http://www.safercar.gov>***

### Noise Emissions

This vehicle was designed, built, and equipped by Blue Bird to conform to all applicable United States Environmental Protection Agency Noise Control Regulations.

*For replacement parts...*

*Contact your Blue Bird Dealer or Parts Sales at  
Blue Bird Corporation.*



## About 2010 Emission Standards

Buses equipped with 2010 diesel engines are designed to conform to stringent federal emissions standards. These standards affect both the equipment installed at the factory and the fuel at the pump.

Buses powered by 2010 emissions standards engines are equipped with special exhaust systems to reduce emissions. The technical details of the systems employed by various engine manufacturers differ, but share common general principles. The exhaust muffler is replaced by a diesel particulate filter which traps and burns microscopic particles in a process referred to as “regeneration.” When heat in the exhaust is insufficient to fully burn the particulates, the system enters an “active” regeneration mode so the necessary catalytic reaction can take place. During active regeneration events, exhaust temperatures are elevated, and an indicator light on the instrument panel illuminates to notify the Driver that regeneration is active. This regeneration mode is automatic and normal, and requires no special action on the part of the Driver. If driving conditions have resulted in insufficient active regeneration then a “manual” regeneration may be required to clean the filter. If this condition occurs an indicator will alert the driver and a maintenance technician should be notified.

Removing particulate matter (soot) from the exhaust stream through regeneration alone will not satisfy the more stringent 2010 emission standard. This standard requires reduced levels of Nitrogen Oxides (NOx). To achieve this a Selective Catalytic Reduction system (SCR) is added downstream of the diesel particulate filter. The SCR system uses a chemical reactant – Diesel Exhaust Fluid (DEF) – which converts to ammonia in the exhaust stream and reacts with NOx to form harmless nitrogen gas and water.

**Fuel Requirements:** As part of the 2007 emissions standards, effective October 15, 2006 the EPA has required fuel retailers to sell lower-emission fuel, designated “ultra-low-sulfur diesel”. After that date, all commercially-available number 1 and number 2 highway diesel fuels are Ultra-low-sulfur diesel. This fuel must be used in all 2013 model buses powered by a diesel engine, as indicated by a decal located near the fuel filler door, reading:

***Ultra Low Sulfur Diesel Fuel Only.***

For detailed information on recommended fuels and other fluids, always follow your engine manufacturer’s guidelines. Also see, Cummins Bulletin No. 3379001.

## Regarding Modifications

Blue Bird Corporation offers many items as standard and optional equipment to meet federal, state, and local specifications and individual customer requirements. This includes, but is not necessarily limited to, stop arms, crossing guards, warning lights, warning light monitors, mirrors, first aid kits, fire extinguishers, warning reflectors, fuses, directional and brake lights, warning buzzers, security/vandal locks, emergency exits, and seat belts.

Emergency equipment must be checked for proper operation daily. It is the driver's responsibility to report any damage to qualified service technicians, and that the condition be corrected before transporting passengers.

Those interested in modification of this vehicle should consult the Service Manual and Blue Bird Engineering Department for a more complete understanding of the vehicle.

**WARNING** *Vehicle alterations, which may cause non-conformance with the Emission Control and/or Federal Motor Vehicle Safety Standards (FMVSS), are expressly not authorized by Blue Bird Corporation. It is the responsibility of the entity undertaking the modification of this product to ascertain compliance with all applicable regulations. Modification must be accomplished in accordance with strict government standards. The entity completing modification of this product must certify that all applicable regulations are met. To certify a modified vehicle, the upfitter must be a licensed vehicle manufacturer, or obtain the services of a licensed vehicle manufacturer for that purpose. Specifically, Blue Bird does not authorize the following modifications.*

- Do not modify the Front or Rear Suspension
- Do not modify the Wheelbase length
- Do not modify or remove the Body or Chassis Crossmembers
- Do not modify the Frame Rail Flanges
- Do not weld on the Engine, Radiator, Fuel Tank(s), Transmission or any component of those items
- Do not modify the Cooling System / Air Intake
- Do not modify the Exhaust / Emission system
- Do not modify the Brake System
- Do not modify the Steering System
- Do not modify the Electrical System and Lights
- Do not modify or obstruct the Mirrors
- Do not modify the Seats
- Do not install any equipment or component nearer than 2 inches (51mm) to the fuel tank(s), rotating components or "jounce" movement of driveline components
- Do not install any equipment or component that will obstruct the flow of air into, around, or from the cooling system
- Do not install any equipment, components, including flooring and/or carpeting, which will obstruct the functioning of the brake and accelerator pedals



For the terms of the Limited Warranty of this Blue Bird product, refer to the Warranty certificate provided in the owner's documents that came with the vehicle.

In addition to the safety issues involved in the modification of the unit, any "unauthorized" modification may adversely affect the warranty of this product by Blue Bird Corporation.

**CAUTION** *All Blue Bird products are certified to meet or exceed all applicable motor vehicle regulations and standards in the "as purchased" configuration. Any modifications are the responsibility of the entity making those modifications. Blue Bird engineering does not authorize any modification of the vehicle.*

The complete line of Blue Bird Service Parts is available from your Blue Bird Dealer. The use of original Blue Bird replacement parts and components will help ensure that your All American remains true to its original design, best preserving performance, efficiency, and safety.

## Before Placing the Bus in Service

It is the responsibility of the bus Owner/Operator to ensure compliance with all federal, state, and local regulations for school bus operation and equipment. As part of a daily pre-trip inspection, the Driver should consider it his/her responsibility to verify that the vehicle is in satisfactory working order and that all emergency equipment is in place, fully stocked (First Aid Kit), up-to-date (Fire Extinguisher), and in proper working condition.

- Check the suspension U-bolt torque.
- Check the service brake adjustment.
- Check the park brake adjustment on units equipped with hydraulic brake systems.
- Check the torque on all the body “tie-down” capscrews.
- Check the engine oil level.
- Check the transmission fluid level.
- Check the engine coolant level.
- Check the air pressure in all the tires.
- Check the torque on the driveline universal joint straps.

Inspection guidelines from individual state inspection manuals (such as Commercial Driver’s License pre-trip inspection procedures) take precedence over those found in this manual. Guidelines found herein are in addition to those in your state’s inspection requirements.

The Driver is responsible for determining that the loading area is clear before stopping to load passengers. The Driver must ensure that all unloaded passengers are clear before moving the bus.

**WARNING** *Emergency equipment must be checked for proper operation daily. It is the Driver’s responsibility to report any damage to qualified Service Technicians and to ensure that the condition is corrected before transporting passengers.*

# ORIENTATION

*This section is to familiarize the Blue Bird All American Driver with the locations of controls and other bus features with which he or she will interact daily.*

## Vehicle Identification

The **Vehicle Certification Plate** certifies that the vehicle conforms to all applicable Federal Motor Vehicle Safety Standards in effect at the date of manufacture. Do not remove or deface this plate.

The **Body Serial and Service Number Plate** is located on the front upper inner panel above the windshield. Refer to the data on this plate for registration purposes or for replacement part information.

The **Axle Record and Chassis Service Number Plate** is located on the front upper inner panel above the windshield. Refer to the data on these plates for registration purposes or for replacement part information.

MANUFACTURED BY	
<b>BLUE BIRD BODY COMPANY</b>	
DATE OF MFR. _____	
INC. VEH. MFG. BY _____	DATE _____
SUITABLE TIRE - RIM CHOICE	
GVWR _____	
GVWR: FRONT _____	WITH _____ TIRES
_____ RIMS,	AT _____ PSI COLD SINGLE
GVWR: REAR _____	WITH _____ TIRES
_____ RIMS,	AT _____ PSI COLD DUAL
THIS VEHICLE CONFORMS TO ALL APPLICABLE FEDERAL	
MOTOR VEHICLE SAFETY STANDARDS IN EFFECT IN _____	
V.I.N. _____	CLASSIFICATION _____

 <b>BLUE BIRD</b>	<b>BLUE BIRD</b>
	<b>FORT VALLEY</b>
	FORT VALLEY, GEORGIA
	BODY NO. _____
	MODEL YEAR _____
	MFG. BODY DATE _____
	STATE / PROVINCE _____
	EQUIPPED CAPACITY _____
	SPECIFICATION YEAR _____
	MAX. DESIGN CAPACITY _____
BODY SERVICE NO. _____	

FURNISH INFORMATION BELOW WHEN ORDERING AXLE PARTS	
CHASSIS SERIAL _____	ENGINE SERIAL _____
FRONT AXLE _____	BRAKE LINING FMSI NO. & FRICTION CODE _____
BRAKE DRUM _____	
REAR AXLE _____	BRAKE LINING FMSI NO. & FRICTION CODE _____
BRAKE DRUM _____	
REAR AXLE RATIO _____	
CHASSIS SERVICE NO. _____	

## ENTRANCE AND EXIT

### Outward Opening Door

Outward Opening Doors are mounted in a prefabricated framework, which eliminates the effect of body construction variations on door and seal operation. Doors are suspended completely on sealed ball bearings located at the top corners of the framework, inside the body. The interlink connection between the doors is a single assembly with oppositely threaded, spherical bearing rod end connectors at each end, providing simple link length adjustment without disassembly. The geometry of the mechanical link between the doors causes the rear door to close well ahead of the front door, so that the front nosing seal rubber always overlaps the rear. Oil impregnated bronze bearings in the lower corners of the framework serve as pivots (not supports). All controls and mechanisms and the complete lower step tread are sealed inside the bus and out of the weather when the door is closed.

The manual control is the Blue Bird over center locking type with built in Safety Latch. The door's ease of operation allows use of a short handle arm, so the handle is six inches closer to the driver in the open position than with the jack-knife door.

Your bus's outward opening door may be actuated by an optional electric control connected to a lever on the front door panel. Depending on option ordered, some doors have mechanically operated switches which control automatic stop positions as well as stepwell and warning lights. Other options allow you to manually control the open and close positions with the switch.

### Outward Opening (Air Door)

The pneumatic actuator is a cylinder connected to a lever on each door, located inside the header cover. An interconnecting link between the doors controls the operation sequence. A safety release valve is located over the door. Air switches inside the header cover operate Stepwell lights and Warning lights. A three position spring loaded switch signals a valve controlling the flow of air to open or close the doors. Air pressure holds the door either open or closed. The operation speed is adjustable by use of flow control valves located on the actuator

### Power Jackknife Doors

Power doors have an air cylinder in the header, for operation of jackknife entrance and exit doors. The door is operated by a switch on the switch panel and a solenoid controlling air flow to the cylinder.

### Emergency Pneumatic Power Door Release

An emergency release valve is located above the door in the header cover. To use the emergency door release, push the lever in the direction of the arrow. This valve exhausts air pressure in the door cylinder, allowing the door to be opened and closed manually.





### Electric Outward Opening Door

The electrically operated outward opening door has a gear box that moves a lever attached to the front door. To open the door, hold the spring-loaded switch in the driver's area in the "OPEN" position until the door stops moving. A limit switch stops the action of the door when fully open. To close the door, move the switch to the "CLOSE" position; the door will stop by means of another limit switch when fully closed. Depending on option ordered there is a keyed switch on the outside of the body, on the cowl panel by the door, which operates the door from outside the bus.

### Emergency Electric Power Door Release

With the door in the fully closed position, pull the release lever in the header panel toward OPEN as far as possible. The linkage will release and the lever will "snap" into a "park" position so it will not return forward when released. Push the door open to exit the bus. To reset the release mechanism, move the lever to its rearward position, and hold the driver operated spring-loaded switch in the "open" position until it clearly engages, or until door is in the fully open position.



*Electric Door Emergency Release*

### Security Lock (Outward Opening Door)

Outward opening doors have an optional key locking mechanism, accessible from outside the bus. A key operated bolt slides into a hole in the header when the door is in the closed position and locked. This option also requires use of the hinged stop on the door control.

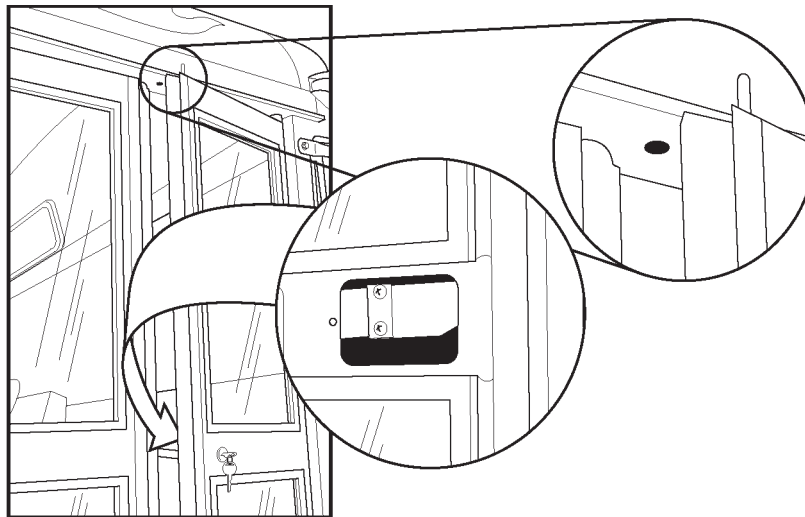

**Manual Security Lock Outward Opening Door**

### Jackknife Door Security Lock

The manual security lock release handle is located in the lower kick panel of the entrance door. It rotates in a counter clockwise direction to latch. It can be locked in the latched position or in the unlatched position. To use the vandal/security lock, the hinged stop on the manual door control cover must be down to prevent the door control arm traveling over center when closing the door.

### Emergency Door Vandal Lock

The emergency door and the rear emergency window may have an optional vandal lock feature, which prevents entry through the emergency exit. There are two types of locking mechanisms; a Cylindrical Key Lock and a Sliding Bolt Latch lock. These locks will prevent the emergency exit from being opened from the outside.

The bus will not start if an emergency exit is locked. An audible buzzer will notify the driver of the locked condition. The Cylindrical Key Lock type mechanism can be unlocked by using the key to remove the cylinder and placing it in the receptacle at the side of the door. For the Slide Bolt Latch lock, simply move the latch to the unlock position. Unlocking the exit in this manner will activate a microswitch which will allow the bus to start. If a lock is activated while the engine is running, an alarm will be activated in the exit and driver's area.

**WARNING** *The bus must not be operated with the emergency exit locked.*

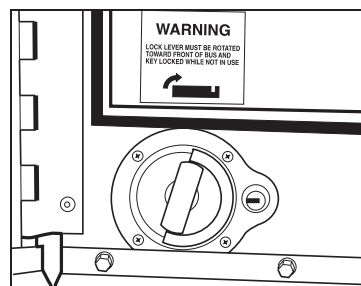

Manual Security Lock Jackknife Door (exterior)

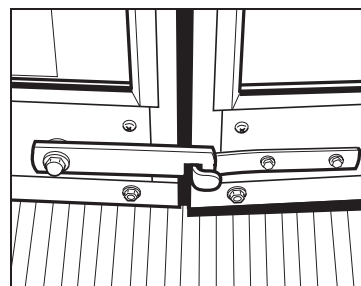

Manual Security Lock Jackknife Door (interior)



## Wheelchair Lifts

Blue Bird All American school buses may be fitted with lifting platforms designed to aid in loading and unloading passengers. There are two optional wheelchair lifts available. The units available are the Ricon™ and the Braun™. Both offer a maximum of 48 inches (122 cm) lift from the ground to the level of the bus floor. For the correct operation and maintenance of the wheelchair lift on your bus, please refer to the operator's manual supplied by the OEM.

**WARNING** *Operators should familiarize themselves with the lift manufacturer's operator's manual prior to loading passengers on the lift. All lifts have maximum weight limits that should never be exceeded.*

These lifts are operated by an independent, electro-hydraulic power system and are controlled by the operator from outside the bus. There is a master switch located in the driver's area that must be activated as well.

The bus electrical system powers a hydraulic pump, internal to the lift, which moves the lift up. The "down" function is gravity type and is controlled by pressure relief valves. Manual operation of the "down" function requires that the operator manually control the pressure relief valves. To provide for the manual "up" function, the lift is fitted with a hand operated hydraulic jack, located on the right-hand (from inside the bus) side of the lift assembly.

A buzzer sounds when the door is unlatched or partially opened. The buzzer stops if the door is completely open.

**DRIVER'S AREA**



- ①
- ②
- ③
- ④

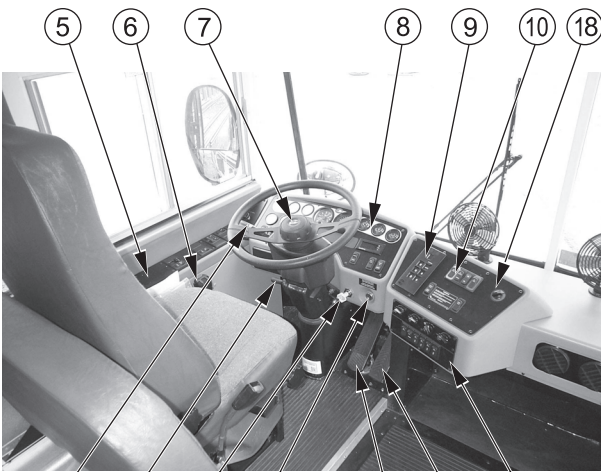

- ⑤
- ⑥
- ⑦
- ⑧
- ⑨
- ⑩
- ⑪
- ⑫
- ⑬
- ⑭
- ⑮
- ⑯
- ⑰
- ⑱

**Driver's Compartment**

1. Auxiliary fans.
2. Radio.
3. Interior mirror.
4. Emergency equipment compartment.
5. Switch panel.
6. PA system.
7. Horn button—sounds electric horn.
8. Instrument panel.
9. Automatic transmission shift control range selector or electronic push button pad location.
10. Warning light, door, and stop arm controls.
11. Hazard light flasher switch (On Steering Column).
12. Tilt/telescopic steering lever (On Steering Column).
13. Parking brake. (Air Brakes)
14. Ignition Switch.
15. Brake pedal or air treadle—applies service brakes.
16. Accelerator pedal—controls engine speed.
17. Heater and defroster controls.
18. Heater Temperature Control



## Dash And Instrument Panel

1. **4 in 1 Gauge.** Consist of the following clockwise from left to right:  
**Fuel Gauge.** Indicates fuel level in tank.  
**Voltmeter.** Indicates electrical system voltage.  
**Coolant Temperature Gauge.** Indicates engine coolant temperature.  
**Oil Pressure Gauge.** Indicates engine oil pressure.
2. **Front Air Gauge.** Indicates air pressure in front brake reservoir.
3. **Rear Air Gauge.** Indicates air pressure in rear brake reservoir.
4. **Speedometer.** Indicates vehicle speed.
5. **Tachometer.** Indicates engine speed.
6. **Diesel Exhaust Fluid Gauge.** Indicates amount of DEF in tank in percentages.
7. **Headlight Switch.** First position activates front park lights and rear taillights. Second position activates front park lights, rear taillights, and headlights.
8. **Dimmer Switch.** Adjusts light level on instrument panel.
9. **High Idle Switch.** Sets engine at high idle speed.
10. Reserved for Special Equipment.
11. **Tire Chains Switch.** Activates on-spot automatic tire chain device. (Optional)
12. **Pedal Adjust Switch.** Two position momentary switch adjusts accelerator pedal to desired position.
13. **Cruise Control On/Off.** Activates or inactivates the cruise standby mode.
14. **Cruise Control Set/Resume.** At the desired cruise speed, set speed by depressing the SET switch. When the brake pedal is depressed, the cruise returns to standby mode. To reactivate to preset speed, depress the RESUME switch after reaching at least 30 mph.
15. **Exhaust Brake.** Activates the exhaust brake to help slow the bus during deceleration.
16. **Warning Bank.** Cluster of indicator lamps. See next page.
17. **Message Display Center.** Displays additional information to the vehicle operator.

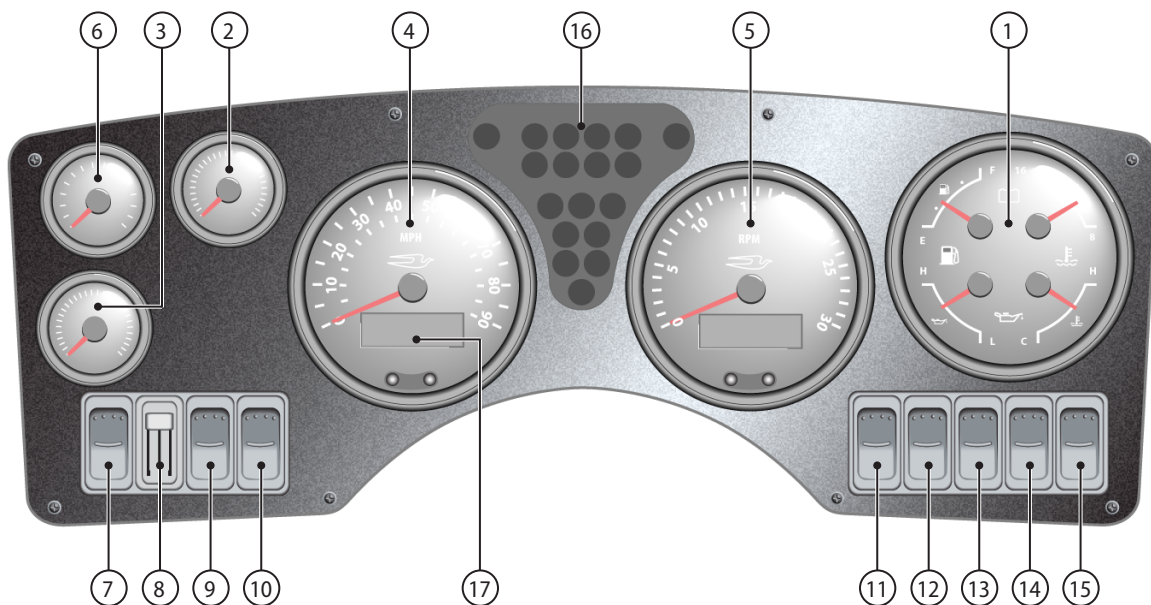

**Warning Bank**

1. **Left Turn.** Flashes with left turn signal.
2. **Brake System.** Indicates a brake system failure. Stop the vehicle and call for assistance.
3. **ABS.** Indicates fault in the anti-lock brakes system. Service as soon as possible.
4. **High Beam.** Headlights are in high beam.
5. **Stop Engine.** The engine ECU has detected a problem which can lead to engine damage. Stop the engine and call for assistance.
6. **Right Turn.** Flashes with right turn signal.
7. **Check Trans.** The transmission needs service.
8. **Trans Temp.** The transmission temperature is beyond normal operating range.
9. **Hydraulic Fluid Temperature.** The hydraulic fluid temperature is beyond normal operating range.
10. **Engine Retard.** The engine retarder is engaged.
11. **Park.** Parking brake is applied.
12. **Low Coolant Level.** Engine coolant is low.
13. **Service Brake.** Lights when service brakes are applied.
14. **Range Inhibit.** The transmission ECU is restricting shifts.
15. **Engine Warn.** The engine needs service.
16. **HEST.** High Exhaust System Temperature.
17. **MIL.** Maintenance Indicator Light.
18. **Wait to Start.** Indicates engine preheating. Wait until indicator goes off before starting engine.

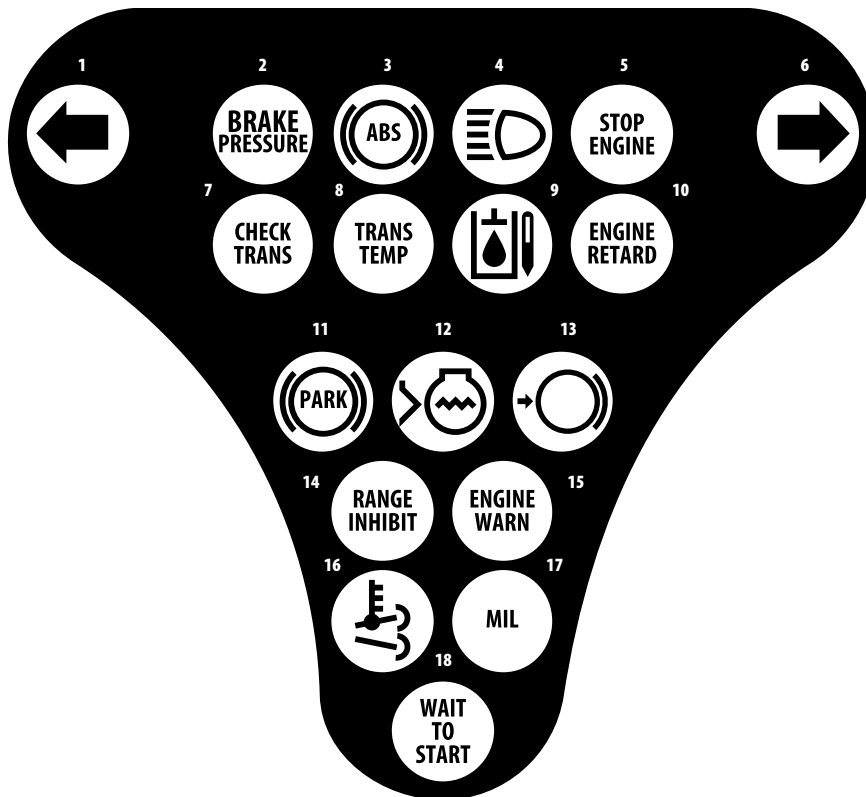



**Switch Panel**

1. Front Dome Lights
2. Rear Dome Lights
3. Driver's Dome Light
4. Fan, Hi-Off-Lo
5. Fan, Hi-Off-Lo
6. Warning Light Master Switch
7. Defroster
8. Noise Suppression Switch

**Note**

*The function of the Noise Suppression Switch is to turn off all heaters and radio to allow the driver to hear sounds outside the bus; for instance, at a railroad crossing. When the switch is in the up position, heater blowers and the radio will not operate. When the switch is down (see illustration), these devices will function in a normal manner.*

## Mirror And Adjustment

**WARNING** The vehicle's mirror system has been designed to comply with all field-of-view requirements, but it is the operator's responsibility to adjust the mirrors properly before placing the vehicle in service and to maintain the adjustment during the service life of the vehicle. Mirrors provide additional driver visibility on buses. To be used effectively, mirrors must be properly adjusted for each driver, and the driver must be aware of the limitations on viewing area that exist even when mirrors are properly used. Mirrors are not a substitute for proper driver training and care that should be exercised when operating the vehicle and loading or unloading passengers. Do not move the bus until you have accounted for each passenger that has disembarked and have confirmed that all passengers are clear of the bus. Failure to follow these procedures could cause serious injury or death.

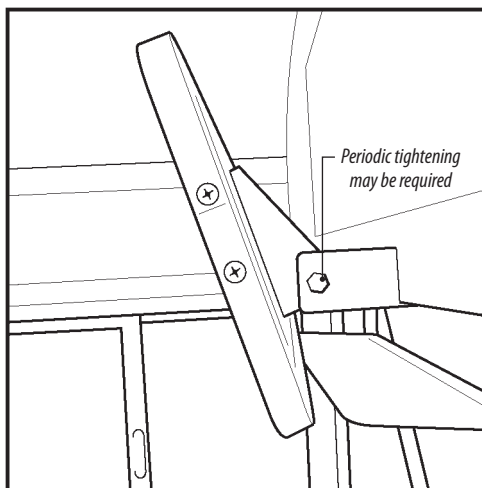

### Interior Mirrors

Inside rearview mirrors can be adjusted by loosening the bolts and nuts in the slotted holes on the mirror brackets. Because this is a friction mount, periodic tightening of these bolts and nuts may be required. Adjust the mirror to give the operator a clear view of the bus interior and the roadway to the rear.

**WARNING** After unloading passengers, do not move the bus until you have confirmed the location of each disembarked passenger, and you are confident all of them are clear of the bus.

### Exterior Rearview Mirrors

Standard equipment on all school buses includes four outside rearview driving mirrors (two per side), and two elliptical cross view mirrors (one per side). The outside rearview driving mirrors include one flat and one convex on each side. The outside rearview driving mirrors are designed to provide the seated driver a view of the roadway to the rear and to the sides of the bus. The elliptical cross view mirrors are designed to allow a seated driver to view all areas around the front of the bus not directly visible. The elliptical cross view mirrors are designed to be used to view pedestrians while the bus is stopped.

**WARNING** Do not use the elliptical cross view mirrors to observe traffic while the bus is moving.

**CAUTION** A convex mirror is designed to provide a wide view with minimum distortion. However, persons or objects seen in a convex mirror will appear farther away than when seen in a flat mirror or viewed directly. Use care judging the size or distance of objects seen in a convex mirror.



Curbside Mirror



Driver Side Mirror



Proper mirror adjustment is necessary for any mirror system to perform as designed. The following adjustment sequence should be used to allow the driver maximum viewing area with the mirror system.

1. Adjust the driver's seat to the desired position.
2. Adjust the right-side, flat, driving mirror so that the tops of the side windows are visible in the upper edge of the mirror, and the right side of the bus body is visible in the inside edge of the mirror.
3. Adjust the right-side, convex, driving mirror so that the view in the top of the mirror overlaps the view provided by the right-side flat driving mirror, and the right side of the bus body is visible in the inside edge of the right-side convex mirror.
4. Adjust the left-side, flat, driving mirror and the left-side, convex, driving mirrors using the same procedures described for the right-side mirrors. Refer to Steps 2 and 3 above.
5. Adjust the elliptical cross view mirrors by positioning each mirror head so that the center of its field of view is aimed at the eyes of the driver.
6. Make a final adjustment to the mirror system so that the seated driver can view the areas required by Federal Motor Vehicle Safety Standard 111 — including the entire top surface of cylinders M and N when located as illustrated, and rearward a minimum of 200 feet (measured from the mirror surface) — using the outside rearview driving mirrors. The elliptical cross view mirrors should be adjusted to provide the seated driver a view of the entire surface of any cylinder A thru P (when located as illustrated) not visible by direct view of the driver. The view provided by the elliptical cross view mirrors must overlap the view provided by the outside rearview driving mirror system.

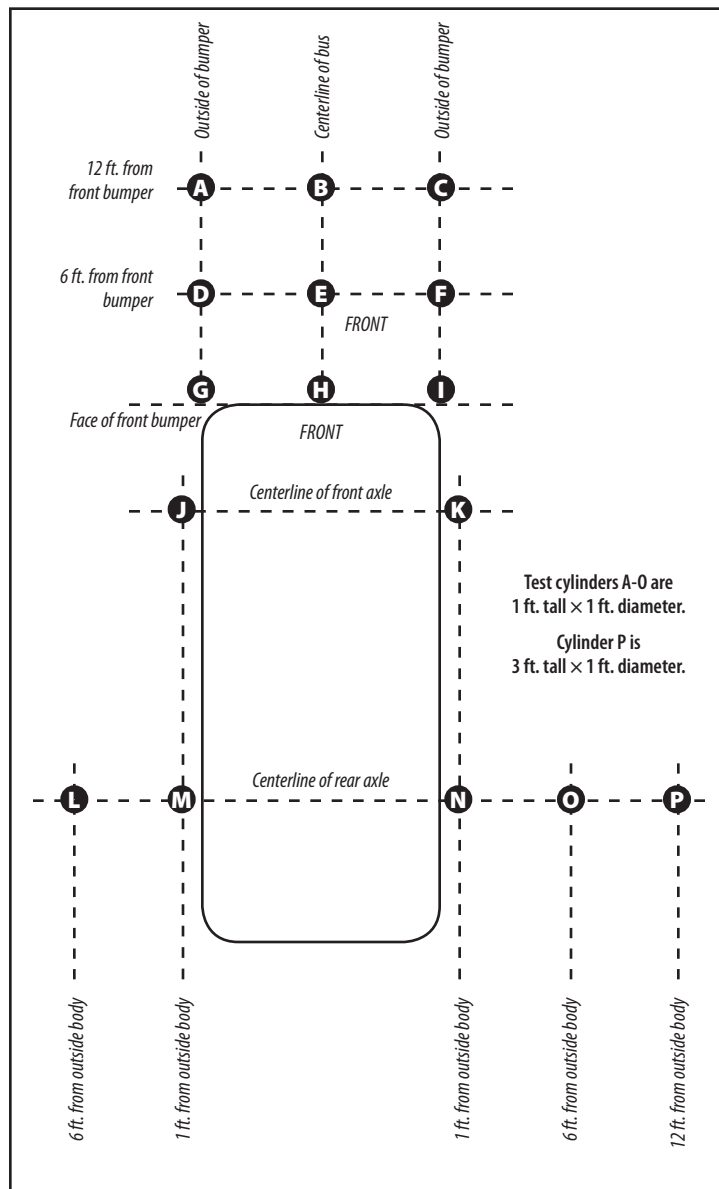

All mirrors should be cleaned once a week (or more if needed), preferably with an ammonia solution. Keep the mounting fasteners tight so that mirrors will not vibrate. Check weekly and tighten, if necessary.

**SEATING**

**Standard Driver's Seat**

To adjust seat position forward or backward, hold lever (A) to the left. Shift the seat forward or rearward to the desired position and release the lever.

A hand operated lever (B) on the right side of the seat allows adjustment of the height of the seat. To raise the seat, crouch in the sitting position but do not apply your weight to the seat. Slide the lever toward the rear. This allows the seat base to raise to the desired position. When in the desired position release the slide handle. To lower the seat apply your weight to the seat while holding the slide handle to the rear. This allows you to leverage your weight to lower the seat. Release the slide handle when seat is in the desired position.

To adjust the back angle, lean forward slightly to remove pressure from seat back and turn adjustment knob at left side of seat cushion. For lumbar support adjust knob at right side of seat back.



**Premium Driver's Seat**

1. Weight and Height Adjustment—to adjust, push in valve knob to raise seat and pull out to lower. When adjusted properly, the seat will not rest against the top, or bottom, limits of vertical motion under normal driving conditions. Adjustment position should also provide for driving visibility and vehicle control.
2. Fore and Aft Adjustment—Hold lever to the left to adjust seat position forward or backward.
3. Back Angle Adjustment—Lean forward slightly to remove pressure from seat back. Hold handle rearward to adjust to any position within range.
4. Cushion Tilt Adjustment—Rotate seat tilt knob to decrease or to increase seat tilt.
5. Lumbar Adjustment—Rotate knob forward to increase, or rearward to decrease, the support in the lumbar area.

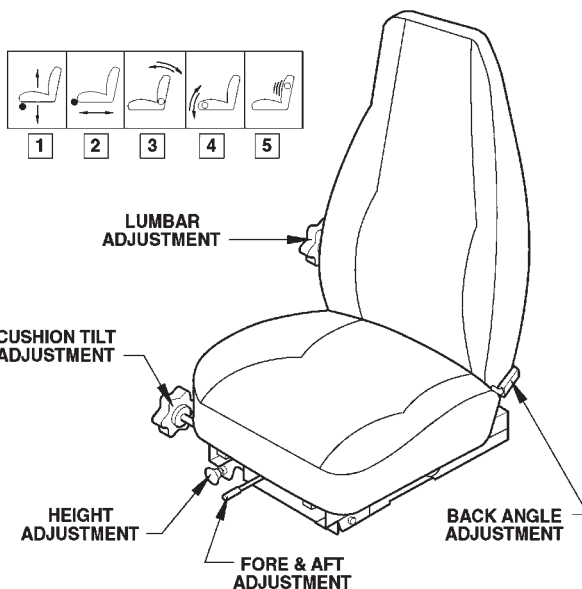

Premium Driver's Seat Controls



**WARNING** Do not attempt to adjust the driver's seat, while the vehicle is in motion. Do not adjust height while sitting in the driver's seat. Keep feet and other items away from height adjustment handles and pedals while vehicle is in motion.

### **Driver's Seat Belt With Shoulder Harness**

The driver's seat belt should be worn at all times when the vehicle is being driven. The driver's shoulder harness locks during emergency stops; the lap belt may be either emergency locking or automatic locking, depending on the option chosen. The emergency locking retractor used for all shoulder harnesses and specified lap belts is dual sensitive. The emergency locking retractor engages when the vehicle tips 15° or if belt payout speed exceeds a preset rate. Automatic locking retractors for specified lap belts are self adjusting. Adjust the shoulder belt bracket for driver comfort.

To use, withdraw an adequate length of belt from the retractor or retractors to allow the buckle. After engaging the buckle halves, let the retractor withdraw the belt to a snug fit. The buckle can be released by pushing the button in its center.

### **Passenger Seat Belts (Optional)**

Individual lap belts for passengers are retractable or non-retractable depending on option ordered. Insert the catch into the buckle, test for positive latch, and pull the loose end of strap until the belt fits snugly across the lower hips. The buckle can be released by pushing the button in its center. The adjustable end can be moved outward on its strap by turning 90° to the strap and pulling.

**WARNING** Be sure the lap belt is fitted snugly around the hips, not the waist. Failure to do so may increase the chance of injury in the event of a collision. Do not bleach or dye the webbing, because such processing may severely weaken the assembly.

## Child Restraint Seats

### Young Children And Infants

Everyone in a vehicle needs protection. This includes infants and all other children. Neither the distance traveled nor the age and size of the traveler changes the need for everyone to use safety restraints. In fact, the law in every state in the United States and in every Canadian province says children up to a certain age must be restrained while in a vehicle.

Every time infants and young children ride in vehicles, they should have the protection provided by the appropriate restraint. Restraints must meet all applicable federal motor vehicle safety standards.

**WARNING** *People should never hold a baby or young child in their arms while riding in a vehicle. During a crash a baby will become too heavy to hold. For example, in a crash at only 25 mph, a 12 lb. baby will suddenly become a 240 lb. force on a person's arms. A baby should always be secured in an infant restraint. Young children must be secured in appropriate child restraints.*

### How Child Restraints Work

A child restraint system is any device designed for use in a motor vehicle to restrain, seat, or position children. A built-in child restraint system is a permanent part of the vehicle. An add-on child restraint system is a portable one that must be installed.

For years, add-on child restraints have used the adult belt system in the vehicle. To help reduce the chance for injury, the child must be secured within the restraint. The vehicle's belt system secures the add-on child restraint, and the add-on child restraint's harness system holds the child in place within the restraint.

When securing an add-on child restraint, refer to the instructions that come with the restraint. These instructions may be labeled on the restraint itself or in a booklet, or both.

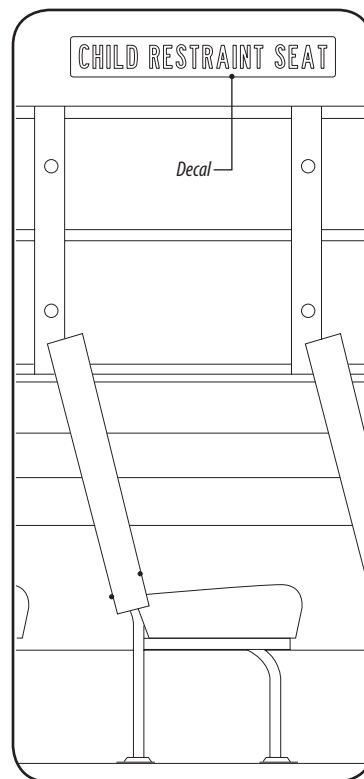



### Universal Child Restraint Anchorage

Seats in this bus equipped with the universal child restraint anchors are identified by a decal located over the seat above the window. (See Decal illustration on the following page.)

This vehicle may be equipped with a universal child restraint anchorage system. If so, you'll find two anchors in the front lower seatback where the bottom of the seatback meets the back of the seat cushion and a third anchor in the lower rear seatback. (See the Universal Child Restraint Anchorage illustration.)

In order to use this system, you need either a forward-facing child restraint that has attaching points (A) at its base and a top tether anchor (B), or a rear-facing child restraint that has attaching points (A) as shown.

Whenever applicable, use the universal child restraint anchorage system instead of the vehicle's safety belts to secure a child restraint.

**WARNING** *If a child restraint isn't attached to its anchorage points, the restraint won't be able to protect a child sitting there. In a crash, the child could be seriously injured or killed. Make sure that the child restraint is properly installed using the anchorage points.*

### Securing A Universal Child Restraint

1. Find the anchors (A) for the seating position you wish to use, where the bottom of the seatback meets the back of the seat cushion. See Universal Child Restraint Anchorage illustration.
2. Put the child restraint on the seat.
3. Attach the anchor points on the child restraint to the anchors in the bus seat. The child restraint instructions will show you how.
4. Attach the top strap to the top strap anchor (B). Tighten the top strap according to the child restraint instructions.
5. Push and pull the child restraint in different directions to ensure it is secure.

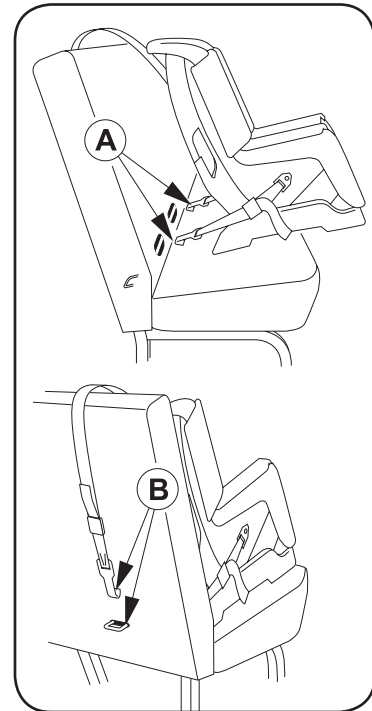

Universal Child Restraint Anchorage

## COMPARTMENTS & ACCESS PANELS

### All American Front Engine

Release the latches on the center panel and allow it to open downward for access to the heater bleeding valve, radiator fill cap, and to view to the radiator sight glass.

Release press button latches on front access doors to the left and right of the center panel for access to windshield wiper motors, windshield wash reservoir (located on the entrance door side), and power steering fluid reservoir (located on driver's side).

### All American Rear Engine

On the Rear Engine models, this allows access to windshield wiper motors, windshield wash reservoir, etc. After closing, press in the larger portion of the latch until it snaps to lock into position.

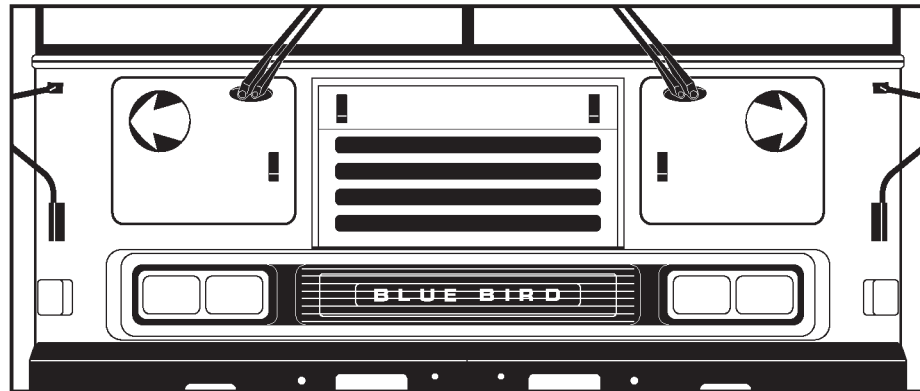



### Engine Access; All American Front Engine

To open the hood, disengage the latch mechanism located in two places on the engine cover. Lift the access cover and allow it to rest fully open on the forward portion of the hood assembly. This will allow access to engine components, such as the oil dipstick, engine oil fill, transmission fluid dipstick, etc.

To remove engine cover assembly for better access to the engine components, loosen the screw type latch mechanisms located at the upper front wall of the engine hood assembly. Open the hood and locate three latches on the inner wall perimeter of the hood assembly. One is located at the rear center and one is located on each side. Releasing these latches will then allow entire hood assembly to be removed for mechanics access.

**CAUTION** *Engine and components can be very hot. If the engine has been running, be careful to avoid burns during engine access and removal process.*

### Engine Access; All American Rear Engine

To open, press the release button on the latches located at the edges of the door (right side shown). Press the upper portion of the handle, located in the lower center of the door for handle access. When the handle swings around, grip and pull to open door. After closing, press in the larger portion of the latch until it snaps to lock into position.

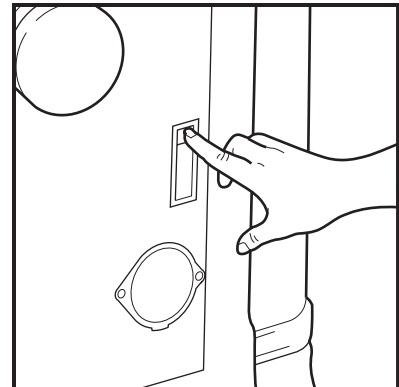

### Rear Side Engine Compartment Doors

To open, press release button latches on the top and the bottom of the rear side access doors. Opening the left side door gives access to the outside of the radiator. Opening the right side door gives access to the right side of the engine. After closing, press in the larger portion of the latch until it snaps, to lock into position.

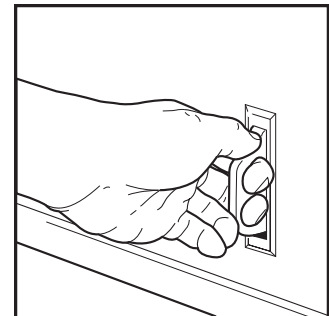
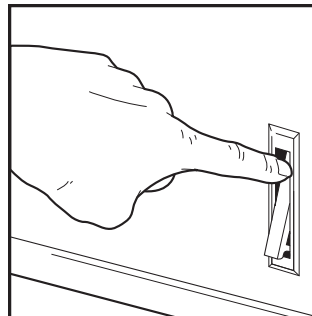

### Additional Access Panels

Other access panels include the electrical access panel, PDU (Power Distribution Unit) access panel, fuel fill, and battery compartment.

The electrical panel access door is located on the outside of the bus below the driver's window. Behind this panel you will find circuit breakers and fuses to the bus *body* electrical circuits. Directly below the electrical panel access is the power distribution unit, accessed from a separate panel. This unit contains circuit breakers and fuses for *chassis* electrical circuits. This unit also has a separate cover with spring latches to help protect the circuits from the elements.

Located behind the front axle on the driver's side is the battery compartment. The latch on this compartment panel is different from the push button type latches on the previous panels. To open, pull the latch handle.

Optional key locks are available on all panel latches.

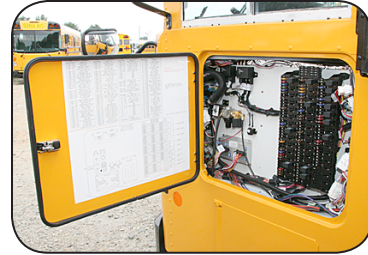

*Body Electrical Panel Access*

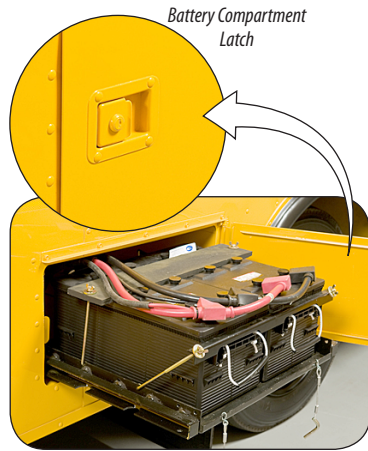

*Battery Compartment*



## **ENROUTE EMERGENCIES**

*Passenger safety is the bus driver's first priority. In the event of enroute emergency or roadside hazard, the driver must be confidently familiar with the location and use of safety devices, emergency equipment and roadside procedures in order to maintain order, guide passengers to safety, and properly position and secure the bus until assistance arrives.*

## EMERGENCY EXITS

Emergency exits are clearly identified by the words “EMERGENCY EXIT.” Operating instructions are printed near each exit. Some units are equipped with an audible alarm which sounds if an emergency exit is unlatched or open. If a buzzer sounds when turning on the ignition switch, check emergency exits to see that they are closed. All emergency exits meet Federal Motor Vehicle Safety Standard 217, “Bus Window Retention and Release.” These illustrations show various types of emergency exits.

**WARNING** All emergency exits should be checked daily to ensure they are clearly labeled and operate properly. Exit windows, doors and hatches must not stick or bind, and must open smoothly and reliably without undue force. Report any damage or defects immediately and repair before transporting passengers.

### Rear Emergency Door

The rear emergency door is opened by lifting the long horizontal handle all the way upward and pushing the door outward. The door is equipped with a hold-open telescoping strut at the top of the opening. When the door is fully opened, a pawl in this strut rotates to prevent the door from falling shut. To close the door, push it outward to the end of the strut’s travel. This causes the pawl to rotate again, allowing the door to close. Close the door smoothly, push it against the frame firmly to compress its seal, and close the handle latch fully.

Rear Emergency Door hold-open strut



### Transpec™ Safety Vent

The roof hatch serves as an important emergency exit. It is important that it is maintained properly and instruction labels are in place and clearly visible. All emergency exits should be inspected and operated daily to ensure that they are labeled and operate according to the instructions provided.

### Maintenance Cautions

Transpec™ Safety Vents are designed to provide years of reliable service with a minimum amount of maintenance. All components are rust proof with lifetime finishes, and moving parts are Teflon™ coated to eliminate need for lubrication. Use of lubricants, paints, or other coatings—such as graffiti-detering spray—is not recommended.

Suggested maintenance includes periodic inspection of attaching fasteners for evidence of loosening due to tampering, and regular cleaning with mild soap and water. Although there are more powerful cleaning solutions available, some of them contain solvents and other chemicals that can attack the high strength materials used in the production of safety vents. It is the customer’s responsibility to ensure that cleaning solutions are compatible with the materials used on safety vents.

Graffiti-removing cleaners often contain acetone, ether, lacquer thinner or other solvents known to destroy the high strength properties of many engineering plastics, and use of these cleaners must be avoided. Graffiti-resisting coatings often leave a sticky residue that interferes with the operation of the ventilator mechanism. Use of these types of chemicals should be avoided.

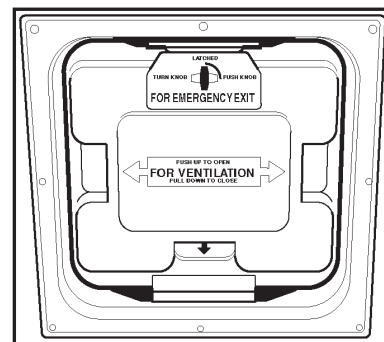

Roof Hatch

Pop up (front or rear) or raise for additional ventilation

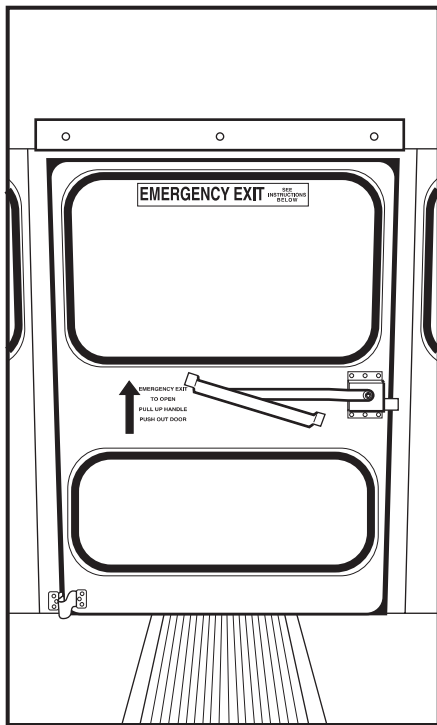

Rear Emergency Door

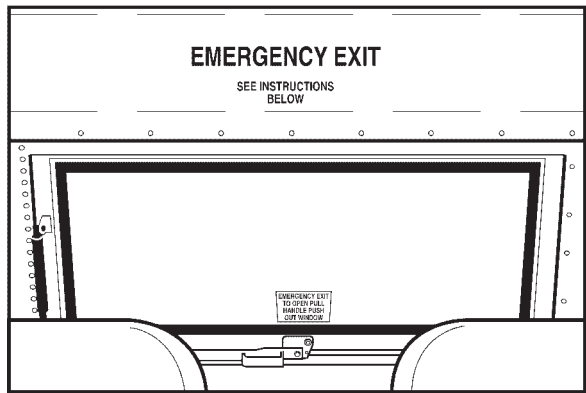

Rear Emergency Window



Split Sash Pushout Window



Side Emergency Door

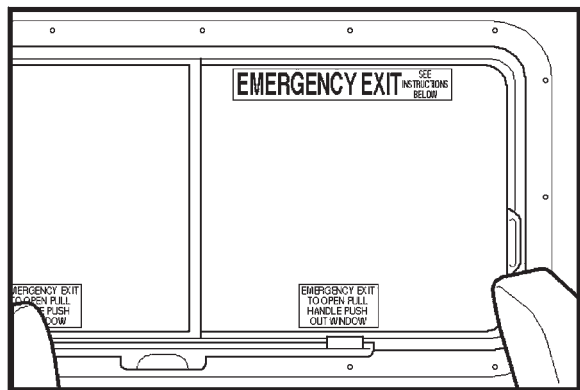

Transit Sliding Pushout Window

**EMERGENCY EQUIPMENT**

Each state or province has unique laws regarding emergency equipment. Your unit may have some or all of the items listed below. Because of variations in option packages, the placement of this equipment inside the bus may vary from one unit to another, but it is important for you to recognize and know the locations of all the emergency equipment on your bus. It is important that you to read, and understand all literature, labels, and other written materials supplied by the equipment manufacturers. Be sure you familiarize yourself with all aspects of the emergency equipment before attempting to drive the bus.

**Fire Extinguisher**

The fire extinguisher is normally located to the left of the entrance door, or in a compartment over the interior rearview mirror, or on the right-hand side of the hood ledge near the stepwell when space is available. Your unit may be equipped with a 2.75, 4.5, 5, or 6 pound extinguisher, depending on the laws of your state or province. Inspect the pressure gauge every 30 days, or as required by individual state fire laws, to be certain the unit is fully charged. Inspect mounting fasteners periodically to be sure they are secure.

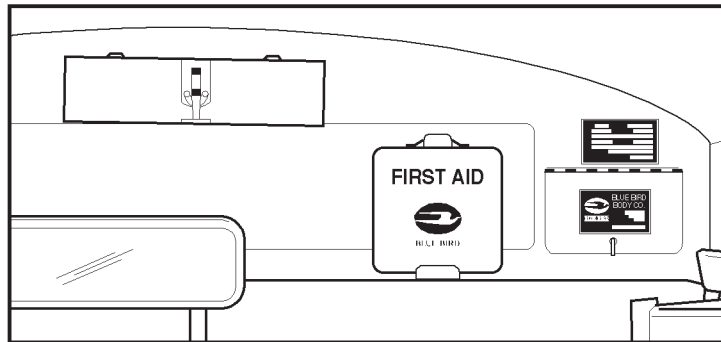

**First Aid Kit**

The first aid kit is mounted in the front of the bus body just above the right windshield. Size and contents of first aid kits vary due to state specifications. The contents of the kit should be inspected weekly or as required by local regulation to ensure that all contents comply with state specifications.

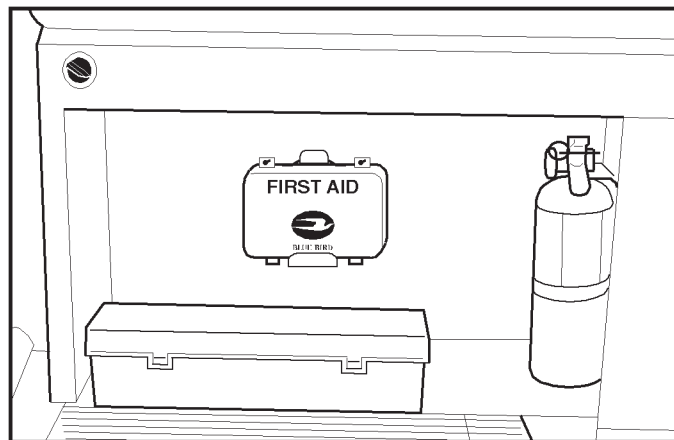

**Body Fluid Cleanup Kit**

The body fluid cleanup kit is designed to contain accidental spillage of biological matter, minimizing risk of exposure to potential health hazards. The contents of the kit should be inspected monthly, or as required by local regulation, to ensure that all contents comply with state specifications.

**Fire Axe/Crowbar**

The fire axe and crowbar are located on the electrical panel access cover to the left of the driver's seat as near to the front as possible. Every 30 days, inspect installation mounting fasteners to ensure that they are secure. Check fire axe and crowbar monthly to ensure that they are easily accessible and unobstructed.



## Flare Kit

The flare kit is mounted on the left-hand side panel behind the driver's seat. Every 30 days or as required by local regulations, ensure that the contents of the flare kit are in place. Inspect mounting fasteners for flare kit box every 30 days to make sure they are tight.

## Triangular Warning Devices

For states requiring the triangular warning devices be located in the driver's compartment, this container is mounted above the windshield at the upper center near the roof line. For other states, it is located on the left-hand rear floorboard, under the rear seat. Inspect contents of the kit every 30 days or as required by local code to ensure proper operation.

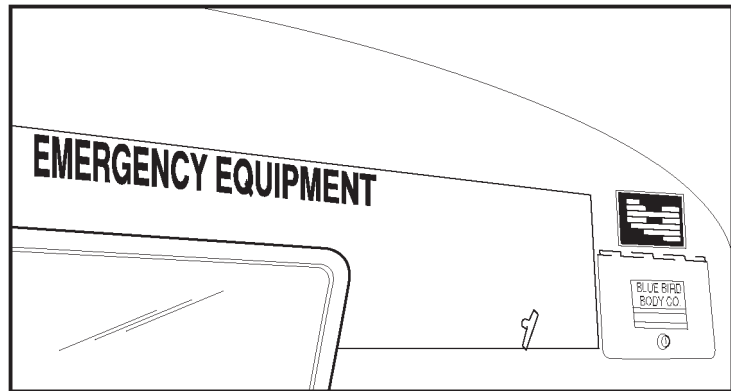

## Recommended Warning Device Positioning

Some states allow a lockable "Emergency Equipment" compartment. This optional compartment is located above the windshield, toward the center of the bus. Supplies are organized and labeled in the compartment. The compartment locking mechanism is fitted with a warning buzzer, which will sound if the compartment is locked while the ignition switch is in the "on" position.

On rear engine units, the emergency equipment is located in the front of the bus. The compartment is located at the centerline of the bus at floor level, depending on the options selected at the time of manufacture.

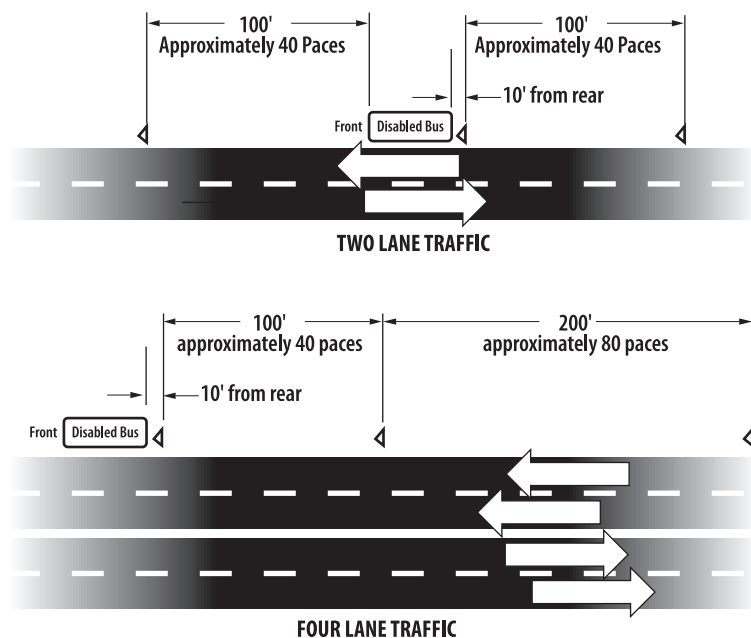

## TIRE / WHEEL EMERGENCIES

### Spare Tire Location And Removal

If your unit is equipped with a frame mounted spare tire carrier, located in the center under the front overhang on RE models and in the rear overhang on FE models, follow this procedure to remove and replace spare:

1. Remove the two securing nuts at the tire mounting plate of the carrier.
2. Remove the access plate located in the riser of the stepwell (RE models).  
Insert the handle through the access hole (in the outside skirt panel on FE models) and into the slotted receptacle of the tire carrier shaft.
3. Slowly lower the tire by turning counter clockwise.

**WARNING** *Hold the handle securely while lowering the tire.*

4. Remove the lifting platform from the tire.
5. To reinstall the tire, reverse these procedures, making certain to tighten the securing nuts at the mounting plate and reinstalling the access plate.

**WARNING** *Never move under a vehicle supported only by hydraulic jacks. Always chock the wheels that are not being raised in both directions. Do not get under the tire/wheel while replacing a flat.*



## Damaged Tires

**WARNING** An inflated tire and rim can be very dangerous when misused or worn out. Many accidents, some fatal, have resulted from improper handling and operation of bus rims and wheels. To help avoid personal injury and/or property damage, get expert tire service help if you can. If you must remove the wheel and change the tire without such help, take the following precautions:

- If the tire seems to contain air under pressure, stand to the side and check whether the wheel assembly appears normal by comparing it to another wheel assembly on the vehicle.
- Let the air out of the tire by taking out the valve core. If you have a way to put air back into a tire, note that it is good safety practice to let the air out of both tires of a dual assembly before taking off the damaged tire and rim assembly from the vehicle. After letting out the air, take off the tire and rim assembly and put on the spare wheel and tire assembly.
- If you are not fully expert on the procedures to follow, and/or are not equipped with the proper tools and equipment, do not attempt to raise the vehicle or remove or install the tire and wheel assembly. Obtain expert tire service help.
- Do not inflate a tire that has been run flat or is seriously low on air without first having the tire taken off the wheel and the tire and tube checked for damage.
- Note that work on bus wheels requires proper tools, safety equipment, and special training. You can be badly injured and/or damage can result from using the wrong service methods. Only trained people using the proper equipment should service bus tires and wheels.
- When putting air into a tire on the vehicle, stand to the side and use a clip on chuck and hose extension. Never add to your tires unless an accurate pressure gauge is also used. In choosing the right tire pressure, be careful not to go past the maximum pressure capacity shown on the tire.

**WARNING** Tire inflation pressure must not exceed the specifications of the tire and/or wheel rim manufacturer for the specific load, speed, and application. The inflation pressure embossed on the tire sidewall does not take the wheel or rim capacities into consideration. Tires should not be inflated above the pressure listed on the label without consulting your tire/wheel Dealer.

## **Wheel And Rim Safety**

Wheels and wheel components must be properly maintained to avoid adverse effects on the life of the tire and/or wheel. An inflated tire is potentially very destructive. Careless handling and inexperience cause accidents. Safety literature can be obtained from your wheel and rim Dealer, a wheel and rim manufacturer, NHTSA, or OSHA. If you have any questions, consult the Dealer or manufacturer directly. The load carrying requirements of each vehicle should also be determined before selecting the proper tire/wheel combination. Always remember that the weakest weight carrying component of the vehicle (i.e., the tires, wheels, axles, bearings, etc.) determines the load carrying capacity for the vehicle.

**WARNING** *Improper handling of wheels and rims has caused many injuries and deaths. Failure to follow directions is the leading cause of such accidents. Obtain procedures from wheel and rim manufacturer before working with a wheel or rim.*

*The tire and wheel must always be properly matched. For example, do not mount a 20-inch tire on a 22-1/2-inch wheel. Failure to strictly adhere to these important instructions may result in an explosive separation and could cause serious bodily injury or death. It is very important to determine the size of each component before beginning any assembly operations.*

*When replacing tires, use the same size, load range, and construction type as originally installed on the vehicle. When replacing wheels, use original equipment manufacturer's wheels or equivalent available from your dealer with equivalent capacity, width, offset, and mounting configuration as those originally installed on your vehicle. Use of improper replacement wheels and tires may adversely affect ride, handling, load carrying capacity, bearing life, the clearance to body and chassis components, vehicle ground clearance, vehicle width, and brake cooling. Do not mix rim, lock ring, and wheel components from different manufacturers.*



## Jacking Instructions

**WARNING** Proper jacking procedures and basic safety measures must be observed to ensure safety of personnel while working under the bus. Always check the serviceability of any lifting equipment prior to use. Ensure that the lifting device is of sufficient strength to handle the bus, and that the surface provides the necessary firmness to support the weight of the bus concentrated on the footprint of the jack. Never move under a bus supported only by a hydraulic jack.

1. Park the bus on flat, level concrete or a comparable surface, capable of supporting the jacking device.
2. Apply the parking brakes.
3. Place chocks at the front and rear of the tires opposite the wheel, or wheels, to be lifted first.
4. Use jacks and jack stands, or blocks of sufficient capacity, to support the vehicle. Following the jack manufacturer's recommended procedure, place the jack securely under the axle at a spring or suspension beam nearest the tire/wheel to be repaired.
5. Jack the bus only to the height necessary to service.

**WARNING** Ensure any locking device on the jack is in place and operating properly. Support the vehicle under the main frame rails with jack stands or blocks before working under or around the bus.

6. After servicing is complete, lift the bus just enough to remove the jack stands or blocks.
7. Carefully lower the bus.

**WARNING** Do not work under a bus supported by jacks. Use only appropriate lifts and/or jack stands supporting frame rails when working under bus.

Rear Jack Point

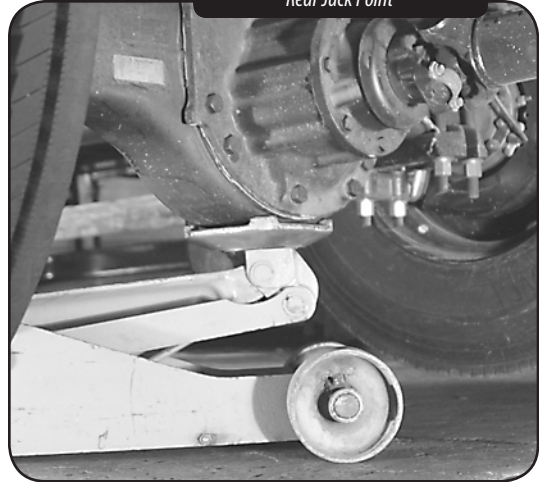

Front Jack Point



### Changing a Flat Tire

The lug nuts are tightened to a torque value of 450 - 500 Ft lb (610 – 678 Nm). Without the proper power tools, it is very difficult to remove the lug nuts. The lug nuts must be “broken loose” before lifting the wheel off the ground.

**WARNING** *Never work around or under a bus supported only with a hydraulic jack.*

1. Remove the lug nuts.
2. Position the spare as near to the hub as possible.
3. You will probably need to raise the hub slightly to position the wheel on the studs (lugs).
4. Hand-tighten all lug nuts.
5. Using the lug wrench, tighten all the lugs about a quarter turn.
6. Remove the blocks or jack stand.
7. Lower the bus enough to lock the wheel in place.
8. Tighten the lug nuts to 50 ft lbs (68 Nm) in the sequence shown.
9. Check the wheel for proper positioning on pilots and proper seating against the flange.
10. Tighten the nuts to 450–500 ft lbs (610 – 678 Nm) in the sequence shown.
11. Lower the jack and remove it from under the axle. Stow the damaged wheel and tire assembly, and the tools.

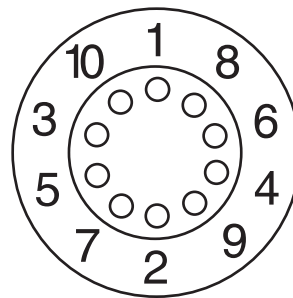



## Schrader Valve

The bus is equipped with a Schrader valve which is located at the end of the wet tank. It allows the air brake reservoir to be charged with a common type air hose normally used by service stations and garages. Charging the system in this manner is only a means of providing air pressure for the air brake system with an inoperable air compressor or without cranking the engine and should only be used for moving the bus while servicing or in case of emergency.

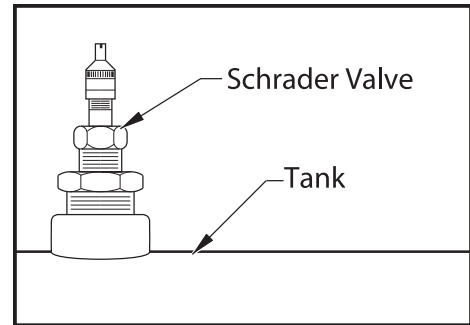

## Releasing Spring Brake Manually

When air pressure fails in the rear service brake chamber, the power spring applies the rear service brakes. Unless pressure can be re-established, the service brakes must be released, as follows, to move the bus.

**WARNING** Do not release the spring brake until the bus is secured by wheel chocks or tow vehicle. Failure to do so may result in bodily injury or property damage.

1. Remove the release stud tool and nut from the carrying pocket on the brake chamber assembly.
2. Remove the access plug from the end of the spring chamber.
3. Insert the release stud through the opening in the chamber and into the spring pressure plate.
4. Turn the release stud one quarter turn to engage the stud tangs with the slot in the pressure plate.
5. Keep the stud engaged and install the nut on the release stud.
6. Tighten the nut until the spring is fully caged and the brakes are released.
7. Do not loosen or remove the release stud and nut unless the brake chamber is completely assembled and is securely clamped.
8. When air pressure is restored, remove the release stud and install in carrying pocket.

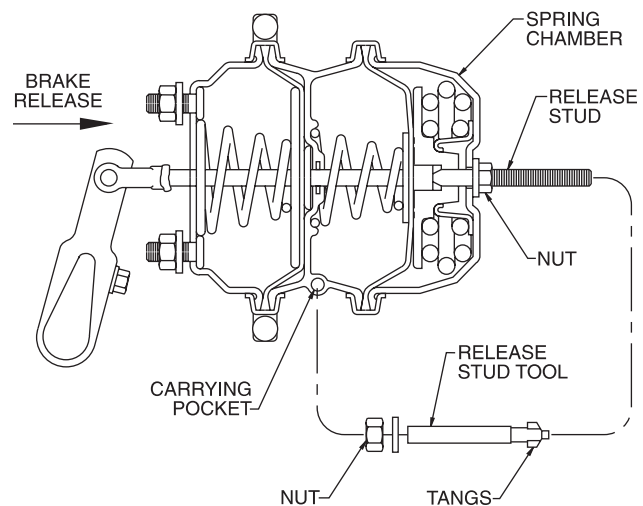

## Towing Or Pushing

**CAUTION** Never tow or push a vehicle equipped with an Allison automatic transmission unless the drive shaft has been removed, or the rear wheels have been raised off the ground. Do not tow by the front axle or any frame cross-member. Damage to the wiring and/or the air lines can result. Optional tow hooks are located at the front and/or rear of the vehicle under the bumper. Tow hooks are designed to tow or pull with both hooks simultaneously. Do not pull or tow with an individual hook. Bumpers provided on Blue Bird buses are designed to protect the vehicle and occupants from front and rear collisions. They are not designed for towing or jacking up the vehicle. Blue Bird does NOT recommend towing or jacking the vehicle by the bumpers.

**WARNING** Exercise extreme caution when the drive shaft is removed on a unit equipped with hydraulic brakes. The parking brake becomes inoperative when the drive shaft is disconnected. Do not leave the bus unattended until taking appropriate measures to prevent vehicle movement. Do not work under the bus when supported by bumper jacks. Use only appropriate jack stands supporting frame rails when under the bus.

**WARNING** Do not lift the bus with the rear tow hooks. These tow hooks should be used for flat ground maneuvering only.

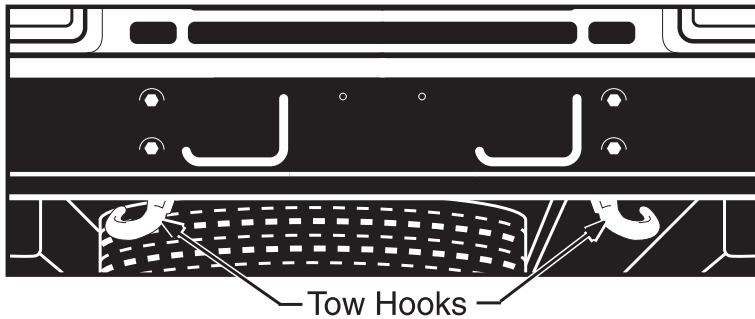

## ROUTINE OPERATION

*Although the controls of a modern bus may appear similar to those of a regular passenger car or truck, the size and weight of the bus and its payload require many differences in design, components, and operating procedures. This section describes special considerations in operation of the engine, transmission, brakes, and other systems.*

Remember: The bus is eight feet wide without outside mirrors and is 25 to 40 feet long. Therefore, it is two feet wider and two to three times as long as the average automobile. Acceleration will be slower than that of an automobile. The inexperienced operator may find that steering, brakes, and other systems feel different from what is familiar. In addition, the driver/operator must ensure that the loading area around the bus is clear of pedestrians before stopping, and that all unloaded passengers are a safe distance away from the bus before moving. For these reasons it is very important, from a safety standpoint, to become familiar with bus operation through experience before attempting passenger transit.

**WARNING** *No one should attempt to operate this bus without: (1) thorough knowledge of all instruments and controls, (2) supervision, or actual driving experience in this or a similar vehicle under supervision, and (3) the appropriate license or permit to operate. Do not drive the bus until the space in front, on the sides, and in the rear is unobstructed. Most accidents occur because the operator did not ensure a clear path before driving.*

Inspection guidelines from individual state inspection manuals (such as Commercial Driver's License pre-trip inspection procedures) take precedence over those found in this manual. Guidelines found herein are in addition to those in your state's inspection requirements.

## PRE-ROUTE INSPECTION

To keep your bus in the best operating condition, any malfunction or defect should be corrected before the next trip. Use the pre-route inspection checklists and report needed services to responsible maintenance personnel.

### Engine/Transmission:

- Check fuel level.
- Drain air tanks.
- Drain fuel/water separator.
- Check engine oil level.
- Check automatic transmission fluid level.
- Inspect engine air intake system, especially the air cleaner service indicator. See Air Intake System Inspection in the General Maintenance section of this manual.
- Inspect the engine coolant level at the sight glass.
- Remove any foreign material and dirt from the outside of the radiator core.

### Body, outside the bus:

- Clean the windshield, mirrors, front windows, headlights, taillights, directional lights, and brake lights.
- Is the tailpipe clear?
- Does the rear emergency door open and close? Check warning buzzer operation.
- Check the wheelchair lift operation, if so equipped.
- Check tire pressure and the treads. Are the lug nuts in place?
- Drain the air brake tank.
- Is the area under the bus all clear?
- How is the general outside appearance? Is it clean? Is there a clear view of identifying features (license plate, school name, bus number, etc.)?
- Are the mirrors clean and adjusted?

### Body, inside the bus:

- Are the seats and floor clean? Are the steps and aisle clear?
- Verify that all emergency exits open and close properly, and do not stick.
- Check the emergency equipment and the first aid kit.
- Is the fire extinguisher in place?
- Are the windshield and windows around the driver's area clean?
- Are the mirrors clean and adjusted?
- Are emergency doors/windows unlocked and operating freely?
- Do buzzers activate when exits are not fully latched?
- If so equipped, does the wheelchair chime sound?

**Starting the engine:**

- Be sure parking brakes are on.
- Put the transmission in Neutral.
- With the key in the "ON" position, check the fuel gauge. Check the brake warning buzzer or light, and the neutral safety switch.
- Start the engine. Look and listen for trouble signs; check the gauges.
- Does the wheelchair lift interlock function properly, if so equipped?

**With the engine running, check (from driver's seat):**

- Mirrors, interior and stepwell lights, service door seal.
- Does the steering feel OK? Is there any unusual noise?
- Check the horn, defroster and heater blower, and windshield wiper operation.
- Does the brake pedal have the right height and feel? Is the gauge reading OK?
- If so equipped, does the wheelchair interlock function properly?

**Outside checks required before driving away:**

- Check turn signals in front and rear. Are they clean and flashing?
- Are flasher warning lights in front and rear clean and flashing?
- Is stop arm clean and working?
- Check high and low beam headlights.
- Are brake lights and taillights clean and working?
- Is hazard flasher working?

**Final check while moving the bus:**

- Is seat belt fastened?
- Do brakes stop and hold?
- Does steering feel OK? Are there any unusual noises? Is bus under control and tracking straight?
- Brake to a stop. Are all gauges OK?

Remember: Safety on the road depends on you. Observe weather and road conditions and drive accordingly. Be physically and mentally alert. When backing up near pedestrians or in congested areas, use someone outside to monitor or direct your movements. Look around before driving away from where you are parked and observe all traffic rules and regulations.

**Weekly Inspection**

- Perform all the Daily Inspection procedures.
- Drain air tanks.
- Check tires. Look for weather checks, worn areas and tread. Check the air pressure.
- Inspect seat cushion attachments for tightness.
- Inspect seat belts and buckles.
- Inspect outside lights for proper operation.

## ENGINE OPERATION

### Engine Exhaust Caution (Carbon Monoxide)

**WARNING** *Never idle the engine in a confined area. Never sit in a parked or stopped vehicle with the engine running. Exhaust gases, particularly carbon monoxide, can build up. These gases are harmful and potentially lethal. Carbon monoxide is colorless and odorless, but can be present with all other exhaust fumes. Do not drive with exhaust fumes present.*

If you suspect exhaust fumes are entering the bus, have the system inspected to determine the source, and make the appropriate corrections immediately.

The best protection from carbon monoxide entry into the bus is a properly maintained engine exhaust system, body, and body ventilation system. It is recommended that the exhaust system and body be inspected by a competent mechanic:

- Each time the vehicle is raised for an oil change.
- Whenever a change is noticed in the sound of the exhaust system.
- Whenever the exhaust system under the body or the rear of the vehicle is damaged.
- Whenever there is an inspection of piping and joints. Replace clamps that are leaking.

Exhaust system clamps are not reusable. Seal with exhaust sealant and install new clamp. Do not run the engine in a confined area (such as garages) longer than necessary to move the vehicle in or out of the area. When your bus is stopped in an open area with engine running for more than a short period, and if it is equipped with combination heating and external ventilation, then adjust the heating or ventilation system to force outside air into bus with the blower set at medium or high speed.

Keep the air inlet grille clear of snow or other obstructions at all times to assure proper operation of the ventilation system. Sitting in a parked vehicle with engine running for an extended period, in either a confined or open environment, is dangerous.

### Diesel Fuel

All American units should take advantage of the high energy content and generally lower cost of No. 2 diesel fuel. Experience has shown that diesel engines will operate satisfactorily on No. 1 fuel. The engine in this vehicle must be operated only with ultra low sulfur diesel fuel (meeting EPA specifications for highway diesel fuel, including a 15 ppm sulfur cap). Also see, Cummins Bulletin No. 3379001.

**WARNING** *Use caution when filling the fuel tank(s) with a high delivery nozzle to prevent spillage. Fuel spray can cause serious injury; vent slowly. Do not fill to more than 95% capacity.*

**CAUTION** *In 2010 emission standard compliant engines, use only diesel fuel labeled Ultra Low Sulfur, per the engine manufacturer's specifications.*

*In Cummins, use oils meeting API CJ-4/SL and Cummins Engine Standard CES-20081. See Cummins Owners Manual ISB 6.7L CM2150 for details.*



## Diesel Engine Starting Procedure

See the appropriate engine manufacturers operating manual for proper starting procedures. Starting procedures vary from different engine manufacturers and also varies with temperature.

1. Apply the parking brake.
2. Place the transmission shift lever in the neutral position.
3. Insert the ignition key and turn it to the ON position. All the instrument panel lights will come on momentarily. Depending upon conditions, the Wait To Start light may remain on. If so, wait until it goes off before trying to start the engine. This gives the engine grid heaters enough time to warm the combustion chambers for efficient starting.
4. After the engine starts, turn on the high idle switch (1,000-1,200 rpm) until the engine is fully warmed up.

**CAUTION** Do not engage the starter longer than 30 seconds without allowing the starter 120 seconds rest.

If the engine fails to start after a reasonable time, determine the cause of the failure. Pumping the accelerator will not assist in starting the engine. Refer to the engine manufacturer's recommended procedures.

**CAUTION** Do not race the engine during the "Warmup" period.

## Starting With Boost Cables

**WARNING** Batteries can emit corrosive and potentially explosive fumes. Prevent sparks near the batteries. Do not allow battery cable ends to contact each other or the engine. Do not smoke when observing the battery electrolyte levels. Electrolytes are corrosive and can cause personal injury if they contact skin or eyes. Always wear protective glasses when working with batteries.

The Blue Bird All American bus has a 12-volt starting system. Use only 12 volts for boost starting. The use of a higher voltage will damage the electrical system.

Always connect the boost cables in parallel with the bus battery cables, negative (-) to negative (-) and positive (+) to positive (+). Do not reverse the battery cables. The alternator can be damaged.

Attach the ground cable last and remove it first.

1. Fasten the positive (+) clamp of the boost cable to the positive (+) post of the battery.
2. Fasten the negative (-) clamp of the boost cable to the negative (-) post of the battery.
3. Start the engine.
4. After the engine starts, disconnect the negative (-) boost cable from the battery.
5. Disconnect the positive (+) boost cable from the battery.

### **Using The Engine As A Brake**

While going down a steep or long grade, it is a good practice to use the engine to retard vehicle speed. Reduce speed before the grade and shift into a lower gear (with either automatic or manual transmissions), being careful to select a gear which will slow the vehicle without over speeding the engine. Under such conditions, use the brakes sparingly, to prevent overheating. Overheating will cause the brakes to “fade”; that is, be less effective.

**WARNING** *Do not take transmission out of gear when the bus is moving. You may not be able to get the transmission back in gear, and the drastic slowing of engine speed could reduce air pressure supply to the air brake system, and result in a reduction of brake capacity.*

### **Engine Warning System**

Your All American bus may have an optional alarm system to signal low oil pressure and high engine temperature. If the engine temperature exceeds the manufacturer’s recommendations, or if the oil pressure drops below the manufacturer’s recommendations, a buzzer sounds and an indicator light glows.

**CAUTION** *If the alarm system sounds, shut the engine off as soon as possible after the bus has been steered to a safe zone. Operation of the engine after the alarm sounds could cause serious engine damage.*



## Exhaust System

New federally mandated emission standards affect all buses equipped with 2010 emission compliant diesel engines. Both nitrogen oxide (NOx) and particulate matter are reduced by 90 percent from 2004 levels. The exhaust system of the Cummins engine in Blue Bird buses are *aftertreatment* systems which incorporate a Diesel Particulate Filter (DPF) and a Selective Catalytic Reduction (SCR) system instead of ordinary mufflers. These sophisticated exhaust systems reduce emissions by trapping exhaust-borne particulates (soot) in a filter built into the DPF. The SCR system then reduces NOx levels through a chemical reaction changing the NOx into harmless nitrogen and water.

Soot accumulates in the DPF over time and must be removed by a process referred to as *regeneration*. Regeneration is conceptually similar to the cleaning mode of a self-cleaning oven in that heat is required to remove the soot.

The rate at which soot accumulates is dependent upon multiple conditions including the quality of the diesel fuel, type of engine oil, ambient temperature, engine load, and other factors. Regeneration occurs in three ways:

- Some regeneration occurs “naturally” whenever operating conditions (speed, engine load, etc.) result in exhaust system temperatures high enough to oxidize accumulated soot. This unassisted regeneration process can generically be referred to as “passive” regeneration.
- Regeneration can be caused by raising the temperature of the exhaust system. Cummins engines are equipped with systems designed to increase exhaust temperature when the ECM senses that regeneration is needed, and when certain requirements, including a minimum travel speed, are met. This automatic “heat assisted” mode can be generically referred to as “active” regeneration.
- Regeneration can be manually activated by means of a switch. This procedure is generically referred to as “stationary” regeneration, and should only be performed by or under the direction of a qualified service technician, and in a controlled environment to avoid the potential for human injury or fire hazards.

The need for regeneration is communicated to the driver by a set of visual and audible signals in the instrument panel. An additional alert, the High Exhaust System Temperature (HEST) indicator, notifies the driver whenever exhaust system temperature is high due to recent regeneration.

Eventually, the normal ash accumulation which results from the regeneration process must be removed from the DPF, using equipment designed for the purpose at qualified engine service facilities. Refer to the engine manufacturer’s documentation for these service intervals. The engine operator’s manual provided with your bus contains additional information about exhaust system regeneration, and should be read and understood by the driver.

**CAUTION** In 2010 diesel engines, use only diesel fuel labeled *Ultra Low Sulfur*, per the engine manufacturer’s specifications.

In Cummins, use oils meeting API CJ-4/SL and Cummins Engine Standard CES-20081. See Cummins Owners Manual ISB 6.7L CM2150 for details.

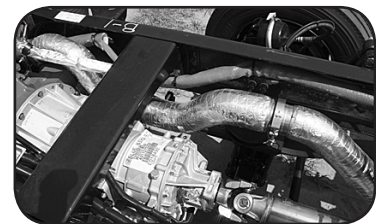

The exhaust systems of 2010 EPA emission compliant diesel engines incorporate engine-specific Diesel Particulate Filters, which operate at higher temperatures during their Regeneration cycles. Due to the hot temperatures generated through the exhaust system, front exhaust pipes, tailpipes, adjacent hoses and tubing are insulated in sensitive areas for protection from the heat on all Blue Bird products.

### **DPF Regeneration In Blue Bird Buses**

As with most new mechanical processes, the introduction of more sophisticated exhaust systems in 2010 emission standards-compliant engines has generated some degree of initial confusion. Engine manufacturers have designed their own methods to accomplish the regeneration (cleaning) of the DPF, and therefore describe the process in somewhat differing terms.

The Cummins equipped Blue Bird bus exhaust system is not complicated nor should the regeneration process be regarded with alarm. Both Drivers and service technicians should be at least conceptually familiar with the regeneration process.

As soot builds up in the DPF filter, the driver is notified in several stages by visual and audible alerts. The alert system is designed to provide reasonable and comfortable fore-warning and adequate opportunity for the needed regeneration. As the need for regeneration becomes more severe, the alerts become increasingly imperative; and the penalty for postponing the needed regeneration also increases.

When the earliest alerts occur, there is typically ample time to complete a route and then have a Stationary Regeneration procedure performed at a proper facility. If early alerts are ignored, and the condition is allowed to worsen, the engine will eventually de-rate automatically, and performance will reduce noticeably. If the condition is allowed to become severe, a Stationary Regeneration may not be possible, and the DPF may require removal and treatment using specialized equipment. Therefore, to minimize disruption of your bus operation, the regeneration-related alerts should be heeded and responded to at their early stages as a matter of routine.

#### **Aftertreatment Terms**

The following summarizes some of the terms associated with the exhaust systems of Blue Bird buses equipped with 2010 emission standards compliant engines. Both the driver and technician should become familiar with the following terms:

**Aftertreatment.** The process of highly filtering engine exhaust in order to reduce emissions, and of purging the exhaust system of accumulated exhaust residue.

**DPF (Diesel Particulate Filter).** A component in the exhaust system which takes the place of a traditional muffler. A DPF contains a special dissimilar metals filter which traps particulate accumulation (soot), which is then converted to carbon dioxide by the aftertreatment process. The Cummins DPF also contains a catalytic converter.

**Regeneration.** The process of cleaning accumulated soot from the filtering components inside the DPF. Regeneration occurs at high exhaust system temperatures to turn the soot into carbon dioxide gas. Regeneration can be thought of as conceptually similar to the clean cycle of a self-cleaning oven.

**WARNING** *Postponing regeneration beyond the early indications may result in the engine being automatically de-rated, and reduction of power while driving.*

**WARNING** *The aftertreatment regeneration process can cause extremely high exhaust gas temperatures hot enough to ignite or melt common materials, and to burn people.*

*Carefully read, understand, and abide by all instructions, warnings, and cautions in the engine manufacturer's operator's manual (and other related engine manufacturer's literature) regarding safe operation when the HEST indicator is on.*

*Carefully read, understand, and abide by all instructions, warnings, and cautions in the engine manufacturer's operator's manual (and other engine manufacturer's literature) regarding safety conditions when performing Stationary regeneration.*



**HEST Indicator (High Exhaust System Temperature).** An instrument panel indicator which appears when the exhaust temperature is unusually high due to recent regeneration. This is normal behavior of the aftertreatment system, intended to notify the driver and technician that the exhaust system temperature is high and that caution should be observed around the exhaust system.

**DPF Indicator.** An instrument panel indicator which displays when particulate accumulation has reached a preset level in the DPF, and regeneration is needed. The bus should either be operated with a more demanding duty cycle until the indicator goes off, or it should be scheduled for a Stationary Regeneration at a service facility.

### Levels of Notification

Regeneration—the process which clears soot accumulation in the DPF—occurs automatically as the bus is operated, as long as certain operating conditions (such as minimum speed thresholds) are met. When bus operating conditions do not provide adequate opportunity for the regeneration system to keep the DPF clear, soot begins to accumulate. A system of driver alerts keeps the driver informed when the exhaust system is in need of regeneration, and of high exhaust temperature associated with regeneration. Several levels of regeneration alerts occur in sequence, each indicating a more imperative warning.

#### High Exhaust Temperature Notification

The High Exhaust System Temperature (HEST) indicator appears to alert the driver when exhaust temperature is unusually high and that prudent judgement should be applied regarding the proximity of people or combustibles to the exhaust system. For example, the bus should not be parked on a surface of grass or weeds.

With the Cummins engine, the HEST indicator appears whenever the exhaust temperature is high (752°F or above), regardless of moving speed.

The driver should be familiar with and abide by all instructions, warnings, and cautions in the engine manufacturer's operator's manual regarding safe operation when the HEST indicator is on.

- The HEST alert appears in the instrument panel.
- The audible alarm sounds one beep.

#### HEST Notification



*The HEST alert appears in the instrument panel's warning bank.*



*The audible alert sounds one beep.*

**Level 1 Regeneration Notification: DPF Indicator Appears**

In low-demand operating conditions, it is possible that the regeneration system does not have sufficient opportunity to prevent particulate build-up in the DPF. The ECM senses that accumulation is occurring and that regeneration is needed. The driver is notified as follows:

- The DPF Regeneration alert activates.
- The audible alert sounds one beep.

The above indicates that regeneration of the DPF is needed at the earliest convenience. The regeneration can be accomplished in either of two ways: If practical, the bus could simply be operated for a while at a speed above the automatic regeneration threshold; or the bus could be taken to a suitable location to have a Stationary Regeneration procedure performed.

If the bus is operated at a minimum highway driving speed (40 mph Cummins), the automatic regeneration system will activate. If minimum speed is maintained long enough (usually 20-30 minutes), the automatic regeneration mode can likely reduce the soot sufficiently to cause the DPF Icon to go off.

Therefore, the first appearance of the DPF icon should be perceived by the driver as a normal notification of action that needs to be taken, but not as an emergency situation. Typically, even if the bus route does not afford immediate opportunity for higher-speed operation, there is sufficient time to finish the bus route and return to the bus maintenance shop before a higher level of notification occurs. Exactly how much “warning time” the first appearance of the DPF indicator represents is dependant upon specific operating conditions. However, current data from Cummins suggest that, at this level of notification, the DPF needs to undergo regeneration within the next two to six hours of bus operation. If regeneration does not begin, a more imperative notification will activate.

**Level 2 Notification: DPF Indicator Blinks**

If the bus continues to be operated without taking the measures indicated by a Level 1 Notification (described above), particulate accumulation continues, and a more imperative notification occurs:

- The DPF Regeneration alert begins to flash.
- The audible alarm sounds continuously.
- The engine may be automatically de-rated.

The above indications should be interpreted as a more imperative alert that the exhaust system is in need of regeneration soon. As soon as practical, the bus should be operated at or above the minimum speed needed to allow automatic regeneration to activate, or a Stationary Regeneration must be performed. Again, situation-specific variables apply. Current data from Cummins suggest that at this level of notification, the DPF needs to be regenerated within the next one to two hours of bus operation. Otherwise, the third level of notification will occur.

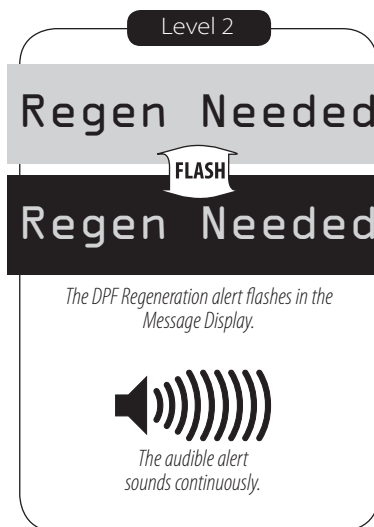
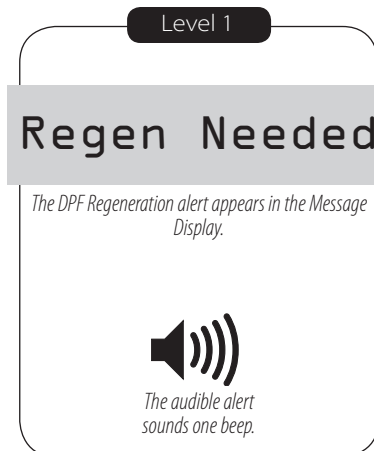



### Level 3 Notification: Check Engine Indicator Appears

If the bus continues to be operated without taking the measures indicated by a Level 2 Notification, particulate accumulation worsens. These indicators are activated:

- The DPF Regeneration alert continues to flash.
- The audible alert sounds continuously.
- The engine is automatically de-rated.
- The Check Engine alert appears.

The above indicates that a Manual Regeneration must be performed as soon as possible. Because the engine is automatically de-rated it may not be possible to drive at sufficient speed to cause active regeneration to occur.

With the Cummins engine, depending upon the severity of the accumulation, the regeneration switch may not be allowed to initiate a regeneration without use of Cummins's PC-based diagnostic software, Insite.

### Level 4 Notification: Stop Engine Indicator Appears

If the bus continues to be operated without taking the measures indicated by a Level 3 Notification, particulate accumulation reaches a critical level. Engine power is automatically *further* de-rated by the ECM. These indicators are activated:

#### **Cummins:**

- The DPF Regeneration alert deactivates.
- The audible alert sounds continuously.
- The engine is further de-rated.
- The Check Engine alert deactivates.
- The red Stop Engine alert appears.

The above indicates that accumulation has progressed to critical levels and the bus should be stopped with the engine off as soon as it is safe to do so. The bus should remain shut down until the aftertreatment system has been serviced.

With the Cummins engine, the regeneration switch will not be allowed to initiate a regeneration without use of Cummins's PC-based diagnostic software, Insite.

Removal and cleaning of the DPF using specialized equipment may be required.

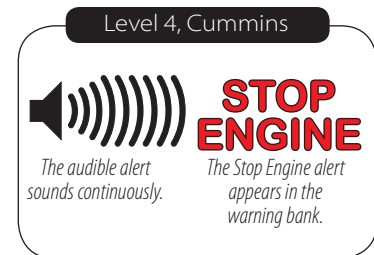
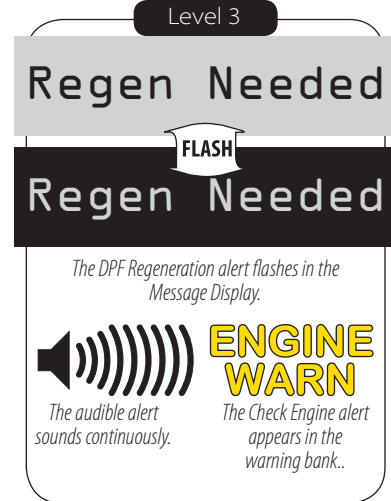

### **Stationary Regeneration Precautions**

During active regeneration, the exhaust system can reach extremely high temperatures. Automatic active regeneration, which occurs while driving the bus, is programmed to occur only when the bus is moving at a minimum speed, and it stops when the vehicle slows or stops.

With the Cummins engine, the HEST indicator appears whenever the high temperature condition exists.

When performing a Stationary Regeneration, the entire process occurs for an extended period while the bus is stopped. It is therefore critical that prudent human safety and fire hazard precautions are followed. Those precautions include:

- Read, understand, and abide by all the precautions pertaining to regeneration procedures in the engine manufacturer's Operator's Manual.
- If at all possible, the Stationary Regeneration procedure should be conducted at a service facility by trained technicians.
- The Driver's first priority is the safety of the passengers. If a Stationary Regeneration must unavoidably be done by the Driver under a qualified technician's direction, alternate transportation should be arranged first, or passengers should be removed under proper supervision to a location away from the bus.
- Select an appropriate location to park the vehicle.
  - Choose a surface that will not burn or melt under high temperature, such as clean concrete or gravel, *not grass or asphalt*.
  - Ensure that nothing that can burn, melt, or explode (gasoline, wood, paper, plastics, fabric, compressed gas containers, hydraulic lines) is near the exhaust outlet. Abide by all instructions, warnings, and cautions in the engine manufacturer's operator's manual regarding safe operation when performing a Stationary Regeneration.
- Park the bus securely.



- Set the parking brake. Put the transmission in Neutral. Chock the wheels.
- Secure the exhaust area.
  - If bystanders might enter the area, set up barriers to keep people safely away from the exhaust outlet.
  - If the procedure is performed indoors at a service facility, attach an exhaust discharge pipe rated for at least 1500°F.
  - Keep a fire extinguisher nearby.
- Check exhaust system surfaces to confirm that no tools, rags, grease, debris or any other objects are on or near the exhaust system.
- Start the engine.
- Operate the Regeneration Switch to begin the regeneration process.
- Monitor the process. If any unsafe condition occurs, shut off the engine immediately. During the regeneration process, the engine may change speed, and the turbocharger may whistle. When the process is complete, the engine will return to normal idle speed. Exhaust gas and exhaust surface temperatures will remain elevated until they have had time to cool to normal levels.

### **SCR System in Blue Bird Buses**

Selective Catalytic Reduction (SCR) is a Nitrous Oxide control technique for diesel engine exhaust. The SCR system uses Diesel Exhaust Fluid (DEF) a nitrogenous compound which readily decomposes into ammonia. The system process involves the injection of DEF into the exhaust over a catalyst. The DEF converts to ammonia in the exhaust stream. This ammonia then reacts with NO<sub>x</sub> and produces harmless nitrogen (N<sub>2</sub>) and water (H<sub>2</sub>O).

The DEF-SCR system basically consists of three elements:

**SCR Catalyst.** The SCR is located in the exhaust stream rear of the Decomposition Reactor. It is similar in outward appearance to a small muffler. The device is comprised of a canister containing the SCR catalyst which uses the ammonia contained in the injected DEF to react with NO<sub>x</sub>. This reaction is temperature dependent and transforms the NO<sub>x</sub> into harmless nitrogen gas and water.

**DEF dosing system.** DEF is supplied from a chassis mount tank to a Supply Module. The Supply Module is controlled by the Dosing Control Unit. The Supply module and the Dosing Control Unit are located inboard the frame rail. The Supply Module uses a very accurate metering and pumping system to supply DEF to the Dosing Module located at the Decomposition Reactor in the exhaust system. The amount of the DEF injected into the exhaust is controlled by the ECM. Water evaporates quickly and the DEF turns into ammonia when in contact with hot exhaust gases.

**Diesel Exhaust Fluid.** DEF is carried on board the bus as an aqueous urea solution in a 15 gallon storage tank clearly identified as DEF. The storage tank is sized to minimize operator filling, but within packaging and weight constraints of the vehicle. Diesel Exhaust Fluid is urea mixed with water to a 32.5% solution. DEF solution is a clear liquid with a weak ammonia odor.

The SCR system consumes DEF at a rate of approximately 2% of the amount of fuel used, depending on bus operation. Therefore a 15 gal tank of DEF will treat approximately 750 gallons of diesel fuel.

The DEF tank level indicator can be found in quadrant 3 of the message display center located on the instrument cluster. This display provides a constant reading indicating the percent of DEF in the tank. If a problem is identified with the amount of fluid or the quality of the DEF, a priority message will appear in quadrant 1 of the message display center indicating the fault.

Keeping adequate levels of DEF in the tank is crucial to the operation of the SCR system. When low levels in the DEF tank are indicated, refill the tank using only approved DEF solution. The DEF has its own tank and fill port with a cap. You will notice the fill port is smaller than the diesel fuel port. This is to prevent putting diesel fuel into the DEF tank. Conversely, care should be given not to put DEF in the diesel fuel tank. Read all decals carefully before refilling. When filling the DEF tank ensure the vehicle is on level ground and insert the fill station nozzle as far as possible into the fill port adapter to ensure proper auto-shutoff levels.

**CAUTION** DO NOT overfill the DEF reservoir. DEF will freeze and expand at temperatures below 12° F (-11°C). If the reservoir is overfilled and freezes, the expansion of the frozen DEF will cause catastrophic damage to reservoir and/or the vehicle SCR system.

Refer to Blue Bird and Cummins Service Manuals for detailed description of the aftertreatment system.



DEF Fill Door



DEF Fill located to the left of the entrance door.



Diesel Fill

**CAUTION** DO NOT put diesel fuel in the DEF tank. DO NOT put DEF in the fuel tank of the bus.



**DEF Levels of Priority Notification**

A system of driver alerts keeps the driver informed of when the DEF is in need of service. When fluid is low or contaminated, several levels of alerts occur in sequence, each indicating a more imperative warning. When priority warnings occur, they will appear in the Message Display Center while the gauge indicates fluid level in the DEF tank at all times. The notifications are as shown below.

**DEF Level 1.** When the DEF level reaches 10% in the tank, a **DEF LEVEL LOW** warning will appear in the Message Display Center at which point the amber DEF warning icon will appear in the lower left warning bank. This warning is accompanied with a single beep.

**DEF Level 2.** When the DEF level reaches 5% in the tank, a **DEF LEVEL CRITICAL** warning will appear in the Message Display Center. The amber DEF Warning icon will commence flashing in the lower left warning bank. This warning is accompanied with repeating beeps.

**DEF Level 3.** When the DEF level reaches 2.5% in the tank, a **DEF LEVEL DERATE** warning will appear in the Message Display Center. The amber DEF Warning icon will continue flashing in the lower left warning bank and an additional amber Engine Warning light will appear. At this point a 25% engine torque derate will occur.



Diesel Exhaust Fluid Level Gauge

**Level 1**

**DEF Level Low**

*The DEF Level alert appears in the Message Display.*

*The DEF Warning will appear in the Warning Bank.*

*The audible alert sounds one beep.*

**Level 2**

**DEF Level Critical**

*The DEF Level alert appears in the Message Display.*

*The DEF Warning will appear in the Warning Bank.*

*The audible alert beeps repeatedly.*

**Level 3**

**DEF Level Derate**

*The DEF Level alert appears in the Message Display.*

*The DEF Warning will flash in the Warning Bank.*

**ENGINE WARN**

*The Engine Warning will appear in the Warning Bank.*

*The audible alert beeps repeatedly.*

**DEF Level 4.** When the DEF level reaches 0% in the tank, a **DEF LEVEL EMPTY** warning will appear the Message Display Center. The amber DEF Warning icon will continue flashing in the lower left warning bank and an additional amber Engine Warning light will appear. Continued 25% engine torque derate.

**DEF Level 5.** When DEF system can no longer maintain pressure, a **DEF SPEED LIMIT** warning will appear in the Message Display Center. The amber DEF Warning icon will continue flashing in the lower left warning bank. The amber Engine Warning light will remain illuminated and a red Stop Engine light will appear. At this point a 5 MPH speed limit will be imposed with the 25% engine torque derate.

**Level 4**

## DEF Level Empty

*The DEF Level alert appears in the Message Display.*



**ENGINE WARN**

*The DEF Warning will flash in the Warning Bank.*

*The Engine Warning will appear in the Warning Bank.*



*The audible alert beeps repeatedly.*

**Level 5**

## DEF Speed Limit

*The DEF Level alert appears in the Message Display.*



**ENGINE WARN**

*The DEF Warning will flash in the Warning Bank.*

*The Engine Warning will appear in the Warning Bank.*

**STOP ENGINE**

*The Stop Engine Light will appear in the Warning Bank.*



*The audible alert beeps repeatedly.*



To automatically clear all DEF Level alerts, fill the DEF tank with approved API certified DEF fluid to a level greater than 10%. This can be verified by the DEF level gauge located on the instrument panel.

**DEF Type Level 1.** When incorrect fluid or mixture is introduced into the tank, a **DEF FLUID TYPE** warning will appear in the Message Display Center. The integrity of the DEF solution needs to be checked using a refractometer. DEF system service should be attained within 10 hours or a level 2 alert will be activated.

**DEF Type Level 2.** After 10 Hours at level 1, the **DEF FLUID TYPE** warning remains in the Message Display Center and the amber Engine Warning light will appear in the lower left warning bank. At this point a 25% engine torque derating will occur. DEF system service should be attained within 10 hours or a level 3 alert will be activated.

**DEF Type Level 3.** After 10 Hours at level 2, a **DEF SPEED LIMIT** warning will appear in the Message Display Center. The amber Engine Warning light will remain illuminated and a red Stop Engine light will appear. At this point a 5 MPH speed limit will be introduced with the 25% engine torque derate.

Level 1

**DEF Fluid Type**

*The DEF Type alert appears in the Message Display.*

Level 2

**DEF Fluid Type**

*The DEF Type alert appears in the Message Display.*

**ENGINE  
WARN**

*The Engine Warning  
will appear in the  
Warning Bank.*

Level 3

**DEF Speed Limit**

*The DEF Type alert appears in the Message Display.*

**ENGINE  
WARN**

*The Engine Warning  
will appear in the  
Warning Bank.*

**STOP  
ENGINE**

*The Stop Engine Light  
will appear in the  
Warning Bank.*

There are six SCR System Fault messages which can be displayed when an active fault is identified. Each of these messages has a Level 1, Level 2 and Level 3 notification. The conditions which trigger each of these notification Levels are outlined below and follow the same format. The six SCR SYSTEM FAULT messages which are actually displayed are:

- DEF Tank Level Sensor Disconnected
- DEF Line / Dosing Valve Blocked
- DEF Dosing Valve Disconnected
- DEF Pump Disconnected
- SCR Harness Disconnected
- NOx Sensor Disconnected

**SCR Fault Level 1.** When an SCR System Fault is detected, a SCR SYSTEM FAULT MESSAGE warning will appear in the Message Display Center, this SCR SYSTEM FAULT MESSAGE will flash from positive to negative. The amber Engine Warning light will appear in the lower left warning bank. Engine diagnostic codes should be recorded and appropriate repairs should be made. DEF system service should be attained within 10 hours.

**SCR Fault Level 2.** After 10 Hours at level 1, the SCR SYSTEM FAULT MESSAGE warning will continue to flash from positive to negative and the amber Engine Warning light *WILL* remain illuminated and a 25% engine torque derate will occur. DEF system service should be attained within 10 hours or a level 3 alert will be activated.

**SCR Fault Level 3.** After 10 Hours at level 2, the SCR SYSTEM FAULT MESSAGE warning will continue to flash from positive to negative and the amber Engine Warning light will remain on and the Stop Engine light *WILL* be illuminated. At this point a 5 MPH speed limit will be introduced with a 25% engine torque derate.

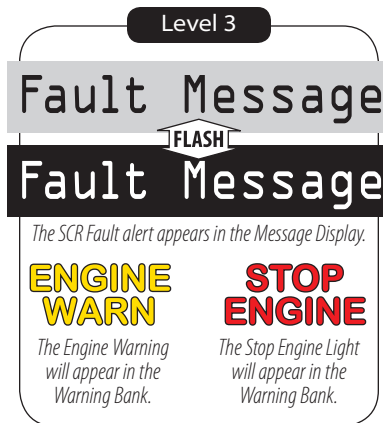
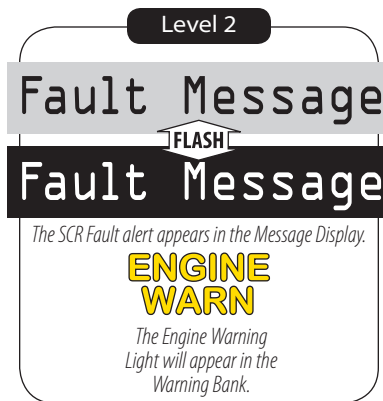
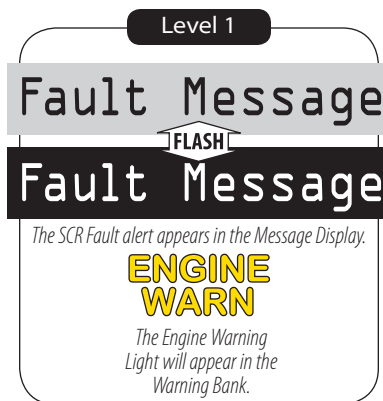



## COMPRESSED NATURAL GAS

**WARNING** *Due to the dangerous potential of high pressure cylinders, it is important that anyone involved in their use be completely familiar with the Department of Transportation "Code of Federal Regulations Title 49" and the various Compressed Gas Association pamphlets that are available covering the care and use of high pressure cylinders. Regulations do not permit filling Natural Gas Vehicle (NGV) cylinders with an overcharge.*

The compressed natural gas (CNG) fuel system consists of DOT-certified CNG storage tanks (which replace the fuel tank), a structure to hold and protect the storage tanks, metallic fuel lines to deliver the fuel, high and low pressure regulators to reduce the pressure entering the throttle body, a fuel shutoff solenoid, and the throttle body which delivers the CNG/air mixture to the engine. The regulator includes an integral heater to preheat the CNG for anti-icing control.

A pressure relief system is part of the fuel system. This system is designed to vent the tank contents when pressure and temperature become excessive.

A fill connection is located near the entrance of the bus. If so equipped, the engine powering this bus is engineered specifically for use with CNG. Operation and maintenance procedures are similar to those used on gasoline or diesel engine vehicles. Differences identified are obvious.

### Owner / Operator Responsibilities

The owner/operator should be aware of the code requirements and be familiar with applicable codes which apply to the area of operation. The owner/operator should be aware that fuel cylinders for CNG (Compressed Natural Gas) must be inspected every three years in accordance with NGV-2 specifications. The owner/operator should be aware that cylinder expiration date is fifteen years after the date of the cylinder manufacture. Compressed gas cylinders must be replaced at that time.

Testing and recertification of the compressed gas cylinders is not covered by Blue Bird warranty. Replacement of compressed gas cylinders, at the end of their service life, is not covered by Blue Bird warranty.

### National Fire Protection

**National Fire Protection Association #52 States:** Cylinders shall be manufactured, inspected, marked, tested, retested, equipped and used in accordance with U.S. Department of Transportation (DOT) or Canadian Transport Commission (CTC) regulations, exemptions or special permits specifically for CNG service and shall have a rated service pressure of not less than 2400 psig at 70° F (16.5 MPa at 21.1° C).

Pressure vessels shall be manufactured, inspected, marked and tested in accordance with the rules for construction of unfired pressure vessels, Section VIII (Division 1), ASME Boiler and Pressure Vessel Code.

When a vehicle is involved in an accident or fire causing damage to the CNG container, the CNG container shall be replaced or removed, inspected and tested in accordance with the document under which it was originally manufactured before being returned to service.

When a vehicle is involved in an accident or fire causing damage to any part of the CNG fuel system, the system shall be retested before being returned to service.

Damaged supply lines must be replaced, not repaired.

The owner or user, or both, shall maintain all containers, container appurtenances, piping systems, venting systems and other components in a safe condition.

As a precaution to keep pressure relief devices in reliable operating condition, care shall be taken in the handling or storing of compressed natural gas containers to avoid damage. Care shall also be exercised to avoid plugging by paint or other dirt accumulation of pressure relief device channels or other parts that could interfere with the functioning of the device. Only qualified personnel shall be allowed to service pressure relief devices. Only assemblies or original manufacturer's parts shall be used in the repair of pressure relief devices unless the interchange of parts has been proved by suitable tests.

**CODE OF FEDERAL REGULATIONS #49 states:** In addition to the requirements of this paragraph, cylinders marked DOT-3HT must be qualified in accordance with CGA pamphlet C-8 and must comply with the following:

Cylinders built prior to implementation of FMVSS 304 must be subjected, at least once in three years, to a test by hydrostatic pressure in a water jacket, for the determination of the expansion of the cylinder. A cylinder must be condemned if the elastic expansion exceeds the marked rejection elastic expansion.

Cylinder service life must not exceed fifteen years.

Each cylinder must be inspected and hydrostatically tested every three years in accordance with 49 CFR 173.34(e) as prescribed for DOT-8HT cylinders, except that the rejection elastic expansion criteria does not apply, permanent volumetric expansion must not exceed 5 percent of total volumetric expansion at test pressure and retest dates must be imbedded in the epoxy coatings in a permanent manner other than stamping. Retest dates may be steel stamped on the shoulder of the top head in accordance with 178.BB-15(c). Re-heat treatment or repair of cylinders is not authorized.

## **Fuel System Description**

The fuel system begins with DOT-certified tanks designed to hold compressed natural gas (CNG) up to 3,600 psi at standard day temperature (70° F, or 21° C). The tanks are high strength steel wrapped with fiberglass for additional strength.

The fuel flows from the tank to the engine through manually controlled shutoff valves. These include an integral pressure relief valve consisting of a combination rupture disk (for pressure) and fuse plug (for temperature) to vent the contents of the tank should high pressure and high temperature occur, such as in a fire. The rated temperature for relief is 212° F.

From the valve, fuel flows into a common fuel line through high pressure stainless steel compression fittings. The tanks are joined to the common line through high pressure stainless steel Tees and crosses. Any open tank is connected to any other open tank, so for fueling, the fuel flows through the common line to all tanks. The tank shutoff valves isolate the tanks; the Tees on the valves still have the high line pressure.



Do not uncouple fittings until all tanks are closed and pressure has been purged from the line. The lines are high pressure rated 3/8 stainless steel seamless tubing which carries the fuel to the high pressure regulator.

In refilling, the fuel enters the fill valve on the entrance side of the bus and then flows through a check valve into the common tubing before reaching the tanks.

From the high pressure regulator, the fuel flows to the shutoff solenoid. The ignition switch, engine operation, and the fire suppression system activate the shutoff solenoid. The loss of any of these will shut off fuel supply to the low pressure regulator (LPR).

The fuel gauge is proportional to the pressure when corrected to 70° F. Fuel level is only accurate for the tanks that are open.

### **Safety Cautions And Warnings**

Both gasoline and CNG are volatile, flammable fuels, yet they are safe to work around when necessary precautions are taken. As on a gasoline fueled system, carelessness with CNG can lead to a fire or explosion when a leak occurs. CNG will not pool and spread like gasoline. It has a narrower range of flammability than gasoline, as well as a higher ignition temperature. Despite these relative safety advantages, fire potential does exist. CNG is lighter than air, so it can collect in the higher regions of a room and possibly go undetected, creating fire potential.

Since the fuel system is a very high pressure system employing a flammable gas, all safety issues normally considered in these situations should be applied. Some of the more obvious precautions are listed below. This list is not necessarily intended to be complete, and responsibility for assuring full safety is that of the person(s) doing the work or operating the system.

**WARNING** *Handle natural gas with care. Compressed natural gas is a volatile fuel stored under high pressure. If fuel storage or delivery components are installed, serviced, or operated improperly, fire, explosion, and/or serious injury could result. Do NOT smoke while working on or around natural gas equipment. Avoid flames, sparks, and operation of electrical devices in or around a vehicle with a possible natural gas leak. Properly tighten all connections and thoroughly check for leaks after servicing fuel system. Natural gas fumes may cause sickness or death. Work in a well ventilated area.*

**WARNING** *Protect against high pressure CNG. Compressed natural gas is stored and routed to the engine at a pressure up to 3,600 psi. Do NOT attempt to remove or disassemble any fuel system component while it is pressurized. Explosive separation of components and escaping natural gas can cause serious injury. Avoid the hazard by relieving pressure before disconnecting any CNG fitting or line. Properly tighten all connections and thoroughly check for leaks before applying pressure. Never attempt to over pressurize the system.*

**WARNING** Protect against extremely cold escaping CNG. Compressed natural gas is stored at an extremely high pressure. If compressed natural gas escapes from a leak, it will expand into an extremely cold (-260° F) gas. Severe frostbite may occur from contact with escaping natural gas or its associated components. Avoid the hazard by relieving the pressure before disconnecting any CNG fitting or line. Properly tighten all connections and thoroughly check for leaks before applying pressure.

**WARNING** Storage tanks must be tested according to specified procedures at required dates. Failure to do so relieves the manufacturer of all responsibility and is a violation of federal law. See the manufacturer's label.

**WARNING** After an accident, all tanks, lines, and fittings should be thoroughly checked by qualified personnel before the vehicle is used again.

All valves are closed when turned fully clockwise (viewed from the top of the valve handle), and open when turned counterclockwise (viewed from the top of the valve handle).

**WARNING** Always provide good ventilation, including near the roof and/or the ceiling. Avoid working in noisy environments, because the sound of leaking gas may go undetected.

**WARNING** Never attempt to find a leak with your hands. A large leak can freeze burn the skin. Never place your hands, or any other part of your body, on a leak.

Always have the properly rated fire extinguishers at hand. Be that certain automatic fire suppression equipment is in place and in operating condition.

**WARNING** Avoid heat near pressure relief valves. The manufacturer's rating is 212° F for the relief valve. If it vents, the area will be filled with natural gas.

**WARNING** Rust or corrosion on tanks, lines, fittings, and valves can be a serious problem. Any part with serious corrosion should be replaced. Fiberglass coating on tanks should be in excellent condition. Any cracks or serious scrapes may require tank replacement. Contact the manufacturer.

**WARNING** Tanks cannot be filled to more than 3,000 psi or 3,600 psi temperature-corrected. Use only authorized refueling stations with adequate pressure controls and venting capacity. Venting contents of tanks should follow any federal and state guidelines, including EPA.



**WARNING** *Use only fuel connections designed for use with that on the bus. Do not attempt to force damaged fittings. Keep sources of heat and ignition away from fuel system and refueling apparatus.*

For more information, see drawing #1589001 in the owner's information package supplied with the vehicle.

## Compressed Natural Gas Fuel

The performance and reliability of a natural gas vehicle is dependent upon the quality of fuel used. BTU content of natural gas can vary depending on locale. Excessive moisture can cause loss of power, and regulator freezing. Other contaminants, specifically lubricants and oil, can cause serious damage which is not covered by the engine manufacturer's warranty. In addition, poor quality fuel can affect emission certification.

**CAUTION** *It is the owner's/operator's responsibility to ensure that clean, quality fuel is used to prevent damage to the fuel system components and power plant. Damage caused by poor quality fuel is not covered by Blue Bird warranty.*

Fuel control systems used on engines fueled by compressed natural gas contain electronic sensors and other delicate components that are not tolerant of contaminants. Vehicle performance is dependent upon clean fuel and a regular schedule of vehicle maintenance.

Compressed natural gas is expected to be delivered from the compressor station and storage cascade free of contaminants including oil, water, and particulates. Conditions exist in some CNG fill stations that cause inferior fuel to load into the vehicle's fuel storage system.

## Compressed Natural Gas Filters

Particulate and coalesce type filters are installed in Blue Bird CNG fuel systems. The primary filter is of stainless steel construction and is located at the fill point. This filter can be checked for contamination by closing the main shutoff valve on the frame and then relieving pressure which is trapped between the check valve in the fill nozzle and the main system check valve. The owner/operator should establish a service interval based on quality of gas from the compressor station. It is recommended that the filter sump be checked after the initial fill and every fifth fill thereafter, or on a schedule based on need.

The secondary filter has a black anodized housing and is adjacent to the fuel shutoff solenoid close to the engine. The secondary filter can be checked after relieving system pressure. This is best accomplished by closing the main shutoff on the frame and running the engine until the fuel supply is depleted and pressure is zero. Contamination of the secondary filter should not occur if a proper maintenance schedule has been followed at the fill point primary filter. Contamination of the secondary filter indicates that the CNG storage cylinders on the vehicle are contaminated. The owner/operator should insist that fuel from a compressor station be clean and dry.

Replacement filter elements are available through Blue Bird Service Parts.

**WARNING** *Compressed natural gas is highly flammable, and pressurized gas can cause serious personal injury or death.*

## Refueling

**WARNING** *Refueling must be conducted in well-ventilated areas to prevent accumulation of dangerous gas levels.*

The National Fire Protection Association has recommended guidelines for CNG refueling systems. State and local regulation regarding Natural Gas Vehicle (NGV) refueling may preclude economic feasibility of indoor refueling (such as in New York City). However, the significance of this issue may diminish if increased experience with fuel leads to less stringent regulations.

CNG refueling transfers natural gas under pressure and may be set up as either slow fill or fast fill. Slow fill generally uses overnight refueling and requires less costly refueling station equipment than fast fill. However, fast fill refueling time is only slightly longer than gasoline refueling time. LNG refueling transfers a cold (-260° F) liquid under pressure (around 15 psi) and generally takes slightly longer than conventional refueling because a greater volume of liquid is transferred to compensate for its lower energy content.

The refueling station has a supply connection hose and a coupling that must be properly attached to the fuel system fill valve. The supply side is regulated for maximum pressure and uses a proper purge valve when decoupling from the filler. The regulators and relief valves of the fill station must be checked for proper values and operation.

Fuel enters the bus coupling from the filler connection, travels through a one-way check valve into the fuel lines, and then into any open tanks. Any tank that is open is in communication with any other open tank through the common fuel lines.

**WARNING** *Do not refill with the engine running or any source of ignition or heat nearby. The refueling station must be in a safe working condition with approved operable relief and vent valves.*

A ground stud is provided for attachment of the grounding cable at the compressor station. Check that the tank shutoff valves are open. Any tank with an open valve will be filled; any tank with a closed valve will not. If the bus has been operating with some tanks closed, it is preferable to fill the empty tanks first and then fill the remainder. Fill to the desired pressure. Maximum is 3,600 psi at 70°F. (Most fill stations have a dome valve to make the temperature correction automatically.) When fueling is complete, open the fill connector purge valve. Use only fuel filling couplings designed for use with the CNG. Do not force damaged couplings together.

**CAUTION** *A check valve is included in the system behind the fill connector to prevent backflow of fuel when purging and disconnecting the fuel nozzle.*



The tanks are full at 3,000 psi, or 3,600 psi at 70° F. The pressure will vary with temperature, decreasing with lower temperature and increasing with higher temperatures. Filling apparatus compensates for the temperature effect.

**WARNING** *Never fill to more than permissible pressure. Contact the manufacturer if an accidental overfill occurs.*

### Specific Gravity

The specific gravity of natural gas relative to air (air = 1.00) is 0.56 to 0.62, depending on gas composition. This means that natural gas is lighter than air. In the event of a natural gas leak, the gas will rise and dissipate given open conditions. There is no possibility of CNG accumulating in pools on the ground beneath a spill.

Odorants have been added that allow natural gas to be detected before reaching dangerous concentrations.

In the case of LNG releases, the cold vapor is initially heavier than the surrounding warmer air, so it stays low near the ground (a visible vapor cloud is often formed from the condensation of water in the cold air gas mixture). As the vapor cloud warms, it will increase in volume, rapidly rise and dissipate in an open environment.

### Fuel Toxicity And Safety

Natural gas is a nontoxic gas. However, it is flammable under proper conditions. Also, it can cause suffocation if it displaces enough oxygen. LNG has the added safety concern of being a cold (-260° F) liquid under pressure. Contact with LNG or associated cold components may cause severe frostbite. Furthermore, many common materials change their strength characteristics when exposed to LNG temperatures, thus presenting additional hazards.

**WARNING** *LNG tanks have the potential for explosions under circumstances such as those described for LPG explosions.*

Although natural gas has odorants to aid in detection of leaks, these odorants are removed during liquefaction; thus LNG vapors cannot be detected by smell. LNG odorants have been developed but are not commonly used due to the relatively restricted use of LNG at this time.

### Flammability

Auto-ignition temperature for natural gas at atmospheric pressure is 1,004° F compared to an auto-ignition temperature range of 442° to 880° F for gasoline and approximately 500° F for diesel fuel. The risk of fire in the presence of an ignition source exists when the ratio of air to fuel is within flammability limits (i.e., fuel can not ignite if it is mixed with too much or too little oxygen). The flammability limits for natural gas are 5.3 to 15 % volume of gas in air. For comparison, the flammability limits of unleaded gasoline are 1 to 7.6 % volume of gasoline in air. As a practical matter, there is no oxygen present in CNG cylinders or LNG tanks, therefore ignition within the

cylinder or tank is not possible. In the event of a fuel leak, there will be a small area in which the air/fuel ratio is within the flammability limits. In a closed garage, or within the passenger compartment, ignition conditions are more likely to be met. Odorants used in CNG allow its detection before the lower flammability limit is reached.

### **Antiknock Properties**

Natural gas has a research octane rating of about 130, making it relatively resistant to engine knock. The antiknock property is a result of the high ignition temperature, resistance to auto-ignition, and the relatively low flame speed of natural gas. Antiknock properties allow the use of engine compression ratios in the range of 15:1 (compared to 8:1 to 10:1 for gasoline). The low flame speed of natural gas results in a longer duration of combustion. To compensate for the lower flame speed, ignition timing is advanced. As with other fuels, knock may occur with advanced ignition timing, prolonged combustion (i.e., too lean a mixture), and excessively high compression ratios.

### **Energy Conversions**

100-125 cubic feet NG	=	1.0 gallon gasoline
114,000 Btu	=	1.0 gallon gasoline
136 cubic feet NG	=	1.0 gallon diesel
83,700 Btu	=	1.0 gallon LNG
1 cubic foot NG	=	1,000 Btu

### **Vehicle Performance And Emissions**

NGV performance, fuel economy, and emissions can be significantly altered with vehicle tuning (i.e., ignition timing, air/fuel ratio). Appropriate tuning adjustments can optimize performance, fuel economy, and emissions. Alternatively, a compromise tuning may be effected. Tuning optimization for power generally increases emissions. Substantial improvements in performance and emissions can be obtained using natural gas conversion kits specially designed for a given vehicle make and model. Further improvements can be achieved with factory-built, dedicated NGVs.

### **Starting Procedure**

Make sure that the main shutoff valve and at least one tank valve are open. The fuel gauge shows empty if no fuel is available to the mixer. Check the tank and main fuel shutoff valves if no fuel is indicated on the fuel gauge. (Note that fuel gauge takes time to register after turning the key.)

Starting procedures are the same as for starting a gasoline engine vehicle. With the vehicle in neutral, turn the key until the engine catches. Do not press the accelerator. If the engine has trouble starting, depress the accelerator slightly and release when the engine catches. Pumping the accelerator does not help start the engine. Engine operation and characteristics should be similar to those of a gasoline engine.



## Cold Start

For cold starts, in low ambient temperatures, natural gas has an advantage over liquid fuels because it is already in the vapor phase. With correct conversion kit installation and vehicle maintenance, cold start ability is better with natural gas than with gasoline.

## Operation And Maintenance Of CNG Vehicle Components

CNG vehicles require Department of Transportation (DOT)-certified cylinders for the storage of pressurized (maximum 3,600 psi) natural gas. Refueling port and lines with pressure safety valves must also be installed. High pressure fuel lines from the storage cylinder lead to a pressure regulator/reducer, which reduces gas pressure in one or two steps. In a fuel-injected converted vehicle, a mixer/carburetor must be added for the injection of natural gas. In carbureted fuel systems, a specialized mixer/carburetor for natural gas may be installed. LNG vehicles require insulated, pressurized (10 to 35 psi) fuel tanks. LNG is vaporized in the fuel line and warmed in the heat exchanger, generally located under the hood. The pressure regulator reduces pressure before the vapors are transported to the mixer/carburetor.

**CAUTION** *Do not use CNG pressure lines or vent lines to clamp, hang, connect, or attach any items, including harnesses, hoses, power steering hose, refrigerant hoses, or any other item.*

## TRANSMISSIONS

### Allison Automatic Transmission

**Important:** Allison supplies far more detailed information about your particular transmission than space allows in this manual. Although we try to cover the most important points here, it is imperative that you read and understand the Allison Transmission Operator’s Manual for more details about operation, care, and maintenance. If you did not receive this manual with your bus, please contact the transmission supplier. Both Blue Bird Corporation and Allison Transmissions continually strive to improve the quality and performance of their respective products. For this reason, information and instructions in the Allison Transmission Operator’s Manual supplied with the bus will take precedence over the general information in this publication.

### Allison Model 3000 Series Transmission

The Allison electronic transmission provides five forward speeds and one reverse. Fourth gear is a 1-to-1 ratio while the fifth gear is an overdrive with a 0.75-to-1 ratio. The push-button shift selector is located on the right area of the dash. The transmission and selector must be in neutral to start the engine.

The service brake must be applied before the transmission will shift from neutral to drive or reverse. If an attempt is made to shift the transmission into drive or reverse without applying the service brake it will remain in neutral, an audible alarm will sound, and the Range Inhibit light on the instrument panel will come on. If this occurs, apply the service brake and then select the desired gear.

Transmission and shift selector will return to “N” when engine is stopped and power switched off. If it does not return to “N” or if it starts in any other gear, the unit has malfunctioned. Seek service immediately.

The push-button shift selector has “R”, “N”, “D”, down arrow, up arrow, a “MODE” button, and a digital display. When a range button is pressed, a tone sounds, the “SELECT” indicator displays the chosen operation (if the Electronic Control Unit [ECU] determines the shift is acceptable), and the transmission shifts to the starting range as indicated on the monitor display. In “DRIVE”, selection of a specific gear can be accomplished by pressing the “UP” or “DOWN” arrow buttons. Conditions resulting in the “CHECK TRANSMISSION” light, located in the instrument cluster, will disable the pad and no tones will sound (see Check Transmission Light).

The “MODE” button, located on the push-button shift selector, activates an alternate shift schedule. By default, the start up is in primary or power mode. Pressing the “MODE” button causes the transmission to enter the economy mode. The display will indicate the economy mode is engaged. In economy mode, the transmission shifts to higher gear at lower engine rpm.

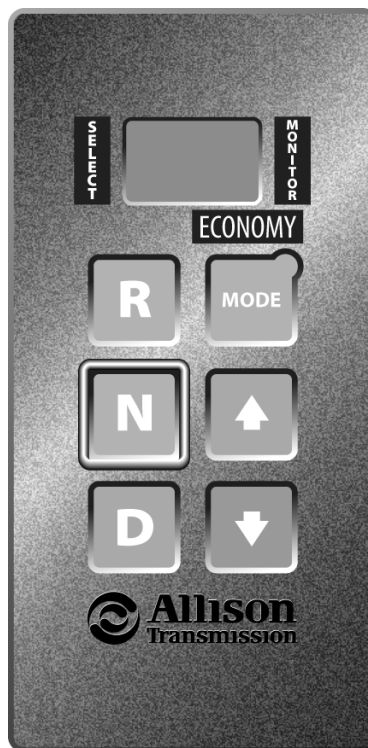



### Allison Model 3000 Series Transmission Gear Selection

**WARNING** *When leaving the vehicle while the engine is running, the operator must ensure the transmission is in "Neutral", the parking brake is engaged, and the wheels are chocked. The vehicle may move unexpectedly without these precautions.*

**R—Reverse.** The vehicle must be completely stopped before shifting from forward to reverse or from reverse to forward. The select indicator and the monitor will display "R" when the vehicle is in reverse.

**N—Neutral.** Use neutral to start the engine, to check vehicle accessories, and for extended periods of engine idle operation. Under normal operation, the transmission is directed by the ECU to neutral during the startup procedure. This occurs automatically with the push-button selector. If the vehicle starts in any range except neutral, seek service immediately.

**WARNING** *Do not allow your vehicle to coast in neutral. This practice can result in transmission damage. Engine retarding and braking assistance is not available when the transmission is in neutral. It may not be possible to get the transmission back into gear while the bus is moving.*

**D—Drive.** When "D" is selected, the vehicle will start to move in first gear and the transmission will upshift automatically through each gear as the speed increases. As the vehicle slows down, the transmission will downshift automatically. The select indicator will display the highest gear available and the monitor will display the current operating gear.

**2, 3, 4, 5 Gears.** Occasionally, the road conditions, load, or traffic conditions will make it desirable to restrict the automatic shifting to a lower gear. Positions "5", "4", "3", and "2" provide progressively greater engine braking for going down grades (the lower the gear, the greater the braking effect). Push the "Up" or "Down" arrow to the desired gear. The select indicator will display your choice and the monitor will display the gear the bus is operating in.

**1 Gear.** Use position "1" gear when pulling through mud and deep snow, when maneuvering in tight spaces, or while driving up or down grades. Low gear provides the vehicle maximum power and maximum engine braking power.

The transmission incorporates a hold feature to prohibit upshifting beyond the gear selected during normal driving. For downhill operation, however, the transmission may upshift beyond the selected gear when the engine's governed speed is exceeded, and damage to the engine is possible.

### Allison Model 2000 Series Transmission

The Allison transmission provides five forward speeds and one reverse. The transmission is controlled with the selector lever located to the driver's right. The selector lever must be in the "N" position (neutral) to start the engine. If the engine starts in any other position, the neutral start switch is malfunctioning and should be repaired immediately. Use "D" (drive) for all normal driving conditions. The service brake must be applied before the transmission will shift from neutral to drive or reverse. If an attempt is made to shift the transmission into drive or reverse without applying the service brake it will remain in neutral, an audible alarm will sound, and the Range Inhibit light on the instrument panel will come on. If this occurs, apply the service brake and then select the desired gear. The vehicle will begin to move in first gear, and as you press the accelerator, the transmission will upshift automatically. As the vehicle slows down, the transmission will automatically downshift to the correct gear. Use "1" and "2" when the road, load, or traffic conditions make it desirable to restrict the automatic shifting to a higher range. When the conditions improve, return the range selector to the normal driving position D. These positions also provide progressively greater engine braking power (the lower the gear range, the greater the braking effect). Use "1" when pulling through mud or snow or driving up steep grades. This position provides maximum engine braking power. Use "R" (reverse) for backing the bus. The bus should be completely stopped before shifting from a forward gear to reverse. Reverse gear provides the greatest traction.



#### Allison 2000 Series Transmission Gear Selection

**WARNING** *When leaving the vehicle while the engine is running, the operator must be sure the transmission is in Neutral, the parking brake is engaged, and the wheels are chocked. The vehicle may move unexpectedly without these precautions.*

**R—Reverse.** Use reverse to back up the vehicle. The vehicle must stop completely, with the engine returning to idle speed, before shifting from forward to reverse or from reverse to forward. If your bus is equipped with a reverse warning signal, it will activate when shift selector is in reverse.

**CAUTION** *Do not idle in "R" (reverse) for more than five minutes. Extended idle time in "R" (reverse) may cause transmission overheating and damage. Always select "N" (neutral) whenever time at idle exceeds five minutes.*

**N—Neutral.** Use neutral to start the engine, to check vehicle accessories, and for extended periods of engine idle operation. If the vehicle starts in any other range, seek service immediately.

**WARNING** *Do not allow your vehicle to coast in neutral. This practice can result in transmission damage. Engine retarding and braking assistance is not available when the transmission is in neutral. It may not be possible to get the transmission back into gear while the bus is moving.*



**D—Drive.** When “D” is selected, the vehicle will begin to move in first gear and the transmission will upshift automatically through each gear as speed increases. As the vehicle slows down, the transmission will downshift automatically.

**CAUTION** *Do not idle in “D” (drive) for more than five minutes. Extended idle time in “D” (drive) may cause transmission overheating and damage. Always select “N” (neutral) whenever time at idle exceeds five minutes.*

**1, 2, D, Gears.** Occasionally, the road conditions, load, or traffic conditions will make it desirable to restrict shifting to a higher gear. Positions “D”, “2”, and “1” provide progressively greater engine power and braking for going down grades (the lower the gear, the greater the braking effect).

**1 Gear.** Use position “1” gear when pulling through mud and deep snow, when maneuvering in tight spaces, or while driving up or down grades. Low gear provides the vehicle with its maximum power and maximum engine braking power.

**Park.** If your bus is equipped with a “Park” selection, use it only after coming to a complete stop, and then apply the parking brake. Do not rely upon the transmission park pawl position alone to prevent the bus from rolling.

### Range Inhibited Light

Under certain operating conditions, the Transmission Control Module (TCM) may determine that it is necessary to restrict gear selection to protect the transmission from damage and provide safer operating conditions. When this happens, the “RANGE INHIBITED” warning light will activate, and the transmission may not respond to the operator’s commands. Please see the Range Inhibited Light and Shift Inhibits section of the Allison Transmission operator’s manual for more information.

### Check Transmission Light

The “CHECK TRANSMISSION” light is located in the instrument panel. The electronic control system is programmed to inform you if operating parameters have been exceeded and to automatically take action to protect the transmission. A diagnostic code will be registered when the “CHECK TRANSMISSION” light is on.

When the engine is started, the “CHECK TRANSMISSION” light turns on for a few seconds. This momentary indication shows that the lighting circuit is working properly.

If the light illuminates after startup, a problem has been detected. A diagnostic code will be recorded and shifts may be restricted. Depending on the problem’s severity, the operator may continue driving to reach service assistance. The TCM may restrict upshifts and downshifts. Please see your Allison Transmission operator’s manual for more details on how shifts may be inhibited.

**CAUTION** *If the transmission will not shift into “D” (drive), or “R” (reverse), it may be because of an adverse operating condition such as; engine RPM too high or service brakes not applied when attempting to shift from neutral. Check for the “RANGE INHIBITED” message or “CHECK TRANS” light. See the appropriate section of the Allison transmission manual.*

## Allison Automatic Transmission Driving Tips

### Accelerator Control

The pressure of your foot on the accelerator pedal influences the automatic shifting. An electronic signal tells the ECU how far the driver has depressed the pedal. This provides the accurate shift spacing and control necessary for maximum performance.

### Downshift or Reverse Inhibitor Feature with Allison 3000 PTS Transmission

Although there is no limitation on upshifting, there is a limit on downshifting and shifts from neutral into drive or reverse. If a downshift or neutral-to-range shift is selected when the engine speed or throttle position is too high, the ECU/TCM will not allow the shift until reaching a lower speed. If idle speed is too high, shifts to range are prohibited. A continuous "beep" tone sounds when reverse is selected during forward movement or if a neutral-to-range shift is selected at too high an engine speed.

### Cold Weather Starts

Most Allison transmissions are programmed to restrict operation until operating temperature is reached. When the transmission fluid temperature is below -25° F (-32° C), the transmission will not shift into an operating range and the "Check Transmission" light will be illuminated. When the transmission fluid temperature is between -24° F and 20° F (-31° C to -7° C), the transmission will operate in 1st, 2nd, or Reverse only. If there is no other problem with the transmission, the "Check Transmission" light will not be illuminated. For transmission fluid temperatures above 20° F (-7° C), the transmission will shift and operate in a normal manner. Be sure to read and understand the cold weather operation instructions in the Allison Transmission™ Operator's Manual supplied with the bus.

### Using the Engine to Slow the Vehicle

To use the engine as a braking force, shift the range selector to the next lower range. If the vehicle is exceeding the maximum speed for a lower gear, use the service brakes to slow the vehicle to an acceptable speed where the transmission may be downshifted safely. After reaching the lower speed, the ECU will automatically downshift the transmission. Engine braking provides good speed control for going down grades. When the vehicle is heavily loaded, or the grade is steep, it may be desirable to select a lower range before reaching the grade. If engine-governed speed is exceeded, the transmission will upshift automatically to the next range.

**CAUTION** *The transmission incorporates a hold feature to prohibit upshifting above the range selected during normal driving. For downhill operation, select a lower transmission range. However, if engine governed speed is exceeded, the transmission may upshift to the next higher range. Use the vehicle brakes to prevent exceeding engine governed speed in the held range.*



**WARNING** *If you only downshift or only use the service brakes when driving down a steep grade, you can lose control. To maintain control, combine downshifting, braking, and other retarding devices. Downshifting to a lower transmission range increases engine braking and helps maintain control. The transmission has a feature to prevent automatic up shifting above the lower range selected. However, during downhill operation, if the engine governed speed is exceeded in the lower range, the transmission may upshift to the next higher range. This will reduce braking and could cause a loss of control. Apply the vehicle brakes or other retarding device to prevent exceeding engine governed speed in the lower range selected.*

## Transmission Indicators

### Check Transmission Indicator

While driving, be alert to any abnormal shifting, unusual sounds or vibrations, smells, or frequent illumination of a transmission priority message. If you experience any of these, get service immediately.

### Transmission Oil Temperature

An oil temperature readout in the message display center on the instrument panel indicates the transmission oil temperature. Extended operations at low vehicle speeds with the engine at full throttle can cause excessive oil temperatures. These temperatures may overheat the engine cooling system and lead to engine and/or transmission damage.

If excessive temperature is indicated by the engine coolant temperature gauge, stop the vehicle and check the cooling system. If the cooling system appears to be functioning properly, shift to neutral and accelerate the engine to 1,200–1,500 rpm. This will reduce the transmission temperature to operating level within two or three minutes. If high temperature persists, stop the engine and have the overheating condition investigated by service personnel.

If the transmission oil temperature readout indicates excessive temperature, check the oil level in transmission (refer to the Oil Check Procedure in your Allison Transmission Operator's Manual). Stop the vehicle and shift to neutral. Accelerate the engine to 1,200–1,500 rpm. The temperature should return to normal within two or three minutes before the vehicle resumes operation. Normal temperature for both on and off-highway operation is 160° to 200° F. Oil temperature should never exceed 250° F. If the sump oil temperature reaches 250° F, the TCM will inhibit operation in the higher gears and turn on a priority message in the message display center indicating high transmission temperature.

If high temperature in either engine or transmission persists, stop the engine and have the overheating conditions investigated by maintenance personnel.

**CAUTION** *The engine should never be operated for more than 30 seconds at full throttle with the transmission in gear and the vehicle not moving. Prolonged operation of this type will cause the transmission oil temperature to become excessively high and will result in damage to the transmission.*

### **Transmission Service Prognostics**

Service prognostics is standard equipment on all Allison Gen 4 transmissions and requires the use of Allison approved TES 295 or TES 389 fluids and Control Main filter. Prognostics is used to predict the need for transmission maintenance. Transmission operating parameters monitored by the prognostics feature are:

1. Oil Life Monitor
2. Filter Life Monitor
3. Transmission Health Monitor

#### **2000 Series Product**

When a specified service threshold is detected for one of the parameters listed above, the TRANS SERVICE indicator in the instrument panel will illuminate to alert the operator to the need for action. Failure to perform the required service and reset the TRANS SERVICE indicator after 100 hours of operation will result in the CHECK TRANS and the TRANS SERVICE indicators illuminating. When the CHECK TRANS indicator illuminates the TCM will register a fault code which will require the use of Allison DOC® for PC-Service Tool to clear the code after the required service has been performed.

**Oil Life Monitor** - The TRANS SERVICE indicator will illuminate when the remaining fluid life reaches approximately 2 percent. The indicator will remain on for two minutes after the initial selection of a drive range. This condition will occur at each startup cycle thereafter until service has been performed. The indicator indicates a required change of the transmission fluid.

After the required service has been performed the TRANS SERVICE indicator can be reset with the Allison DOC® For PC-Service Tool, or by selecting N-D-N-D-N-R-N on the shift selector, pausing briefly (less than 3 seconds) between each selector movement. The ignition must be on and the engine must be off before attempting to reset.

**Filter Life Monitor** - The TRANS SERVICE indicator will flash after reaching time and mileage parameters set in the control module. This indicates the transmission filter needs servicing. It will flash for two minutes after selecting D (Drive) for each startup cycle until service is performed and the indicator is reset.

After the required service has been performed the TRANS SERVICE indicator can be reset with the Allison DOC® For PC-Service Tool or by selecting N-D-N-D-N-R-N on the shift selector, pausing briefly (less than 3 seconds) between each selector movement. Be sure the ignition is on and the engine is not running.

**Transmission Health Monitor** - The TRANS SERVICE indicator will illuminate when the remaining clutch life reaches approximately 10 percent, or if the running clearance exceeds maximum value which may indicate a non-wear-related issue. The indicator will illuminate and remain on until the required service is performed and the indicator reset.

The indicator will reset automatically upon elimination of the clutch clearance condition which initiated it. The indicator can also be reset using the Allison DOC® For PC-Service Tool if necessary.



**3000 Series Product**

Electronic shift selectors used with 3000 series transmissions have an integrated service icon in the shape of an open-end wrench located between the SELECT and MONITOR displays, which illuminates or flashes when a specified service threshold is reached for one of the three prognostic parameters.

When service is due for Allison 3000/4000 Series transmissions, a wrench icon on the shift selector’s digital display alerts the operator. You can check the status of all three prognostics (oil, filter, clutch) simply by advancing through the shift selector’s display using the diagnostic button or the up/down arrow buttons.

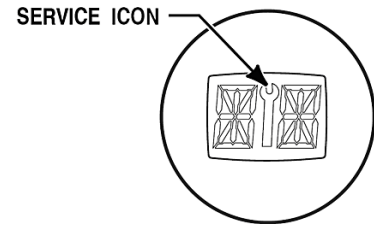

**When the fluid is due for a change:**

The wrench icon stays illuminated for two minutes after the Drive range is selected.



**When the filter(s) is due for a change:**

The wrench icon flashes on and off for two minutes after the Drive range is selected.



**When clutch maintenance is due:**

The wrench icon comes on and stays on in all ranges.

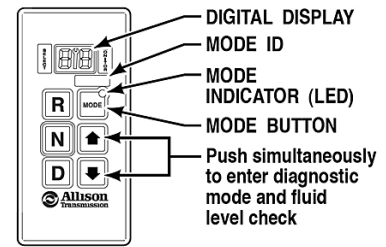

**Hydraulic Retarder (If Equipped)**

- The hydraulic retarder control lever is mounted on the vertical panel, left of the driver. It has five positions (one “off” and four retard positions). Each higher number increases the amount of retardation to slow the vehicle.
- Remember the retarder is a vehicle slowing device, not a stopping device. A full stop must be accomplished with the service brakes.
- Always release the accelerator completely before applying the retarder.
- Do not use the retarder when road surfaces are slippery.
- Consult the retarder manufacturer’s Owner’s or Operator’s Manual for additional information.

## **BRAKING**

### **Antilock Braking System (ABS)**

In a vehicle equipped with an antilock braking system (ABS), motion sensors detect the speeds at which the wheels move. These sensors transmit this information to an Electronic Control Unit (ECU). If the wheels start to lock, the ECU signals the modulator assembly to regulate the brake pressure of each locking wheel.

An ABS indicator lamp on the dash (see "Indicator Light Panel" in Instrument Panel section) warns the driver of possible system faults and provides blink code information to diagnose the system. If this light is activated during normal vehicle operation, the driver may complete the trip, but the vehicle must be serviced as quickly as possible.

### **Hydraulic Brakes**

**WARNING** *Do not tap into the brake system or the power steering system to provide pressure for accessories. Tampering with either of these systems could result in loss of braking ability and/or steering ability.*

**CAUTION** *Hydraulic brake systems are power-assisted. Braking capacity is reduced without engine assist. Do not move bus with dead engine.*

The electric power backup pump will operate whenever the engine is not operating and the key switch is in the ON position, or when the key is in the "OFF" position and the brake pedal is depressed. Test daily by feeling for the electric motor operation while applying the brakes with the engine not operating, or when the key switch is in the "ON" positions and the engine is not operating. Initially, the pedal will be hard to push, but will become softer as the electric motor starts.

**WARNING** *Do not drive the bus when the electric backup pump does not operate properly.*

#### **Dual Brake System**

The dual brake system allows the driver diminished brake capacity in case either the front or the rear brake circuit fails.

**CAUTION** *When one section of the dual system fails, the following conditions will exist.*

1. *Bus stopping distance will increase. Drive the bus only with extreme caution. Service immediately!*
2. *The brake pedal will be softer to push.*
3. *The brake pedal will travel farther than normal.*



### Brake Warning System

The brake warning system includes a buzzer and a dash-mounted red light labeled "BRAKE SYSTEM". The light and buzzer will activate during the following conditions:

- Engine is running, brakes not applied, with a loss of electrical power to the electric backup pump motor.
- Engine is running, brakes not applied, with a loss of power assist from the power steering pump.
- Engine is running, brakes are applied, and either the front or rear section of the system has failed. The backup pump, buzzer, and light will remain on even after the brake pedal has been released.
- Engine is not running, brakes are not applied, but ignition key is "ON". This condition should happen every time the driver starts the bus. The bus should not be driven if the backup pump system is not working. The backup system should go off when the engine starts.
- Engine is not running, brakes are applied, and ignition is in ON position. This is a method for checking the backup pump.

With the engine not running and the ignition "OFF", a depressed brake pedal will cause the backup motor to run with no light and buzzer. The backup system should go off when the pedal is released. Without the assist of the power steering pump and without the assist of the backup pump, the master cylinder will allow the brakes to be applied. However, brake capacity will be very limited and the bus should not be driven under these conditions.

### Parking Brake (Hydraulic Brakes)

A Blue Bird ALL AMERICAN equipped with hydraulic brakes employs a hand-operated parking brake, located to the Driver's left. When the driver pulls this lever into the engaged position, a mechanical linkage causes a brake shoe assembly to extend and contact a brake drum attached to the driveshaft, preventing the bus from moving.

**CAUTION** *This type parking brake becomes inoperative if the driveshaft is disconnected, as when the bus is being prepared for towing.*

**WARNING** *Improper adjustment of the parking brake can significantly reduce the holding ability of the parking brake system.*

The parking brake should hold the fully loaded bus on a 20% incline on a dry paved surface. If the incline is wet or covered with ice or snow, do not park on it. The brake will hold, but the tires may not. The parking brake is not to be used as a normal service brake, but can be used to help stop in an emergency situation.

**WARNING** *The parking brake is designed to hold on a 20% grade, on a clean, dry, and smooth road surface. Parking on wet, icy, snow-covered or loose aggregate surface will greatly diminish braking efficiency and is not recommended. Always use wheel chocks.*

When the parking brake is applied, and the ignition switch is "ON", a dash-mounted yellow light labeled "PARK" will warn the driver that the brake is applied. The bus should not be driven when the parking brake is applied. Doing so will prematurely wear the parking brake or damage other drive train components.

**CAUTION** Always release the parking brake fully. Leaving it in a partially released position can allow the shoes of the parking brake mechanism to drag while the bus is operated, resulting in overheating and accelerated wear of the parking brake shoes and drum.

**WARNING** The parking brake functionality relies on the rear wheels remaining in contact with the surface the bus is parked on. If one or both wheels are lifted off the surface the park brake will not function and the bus may move resulting in potential bodily harm or death.

### Hydraulic Brake/Throttle Interlock System (Optional)

The hydraulic brakes system of some All Americans include an optional Brake/Throttle Interlock feature which, when active, automatically applies the brakes and disables the throttle when the vehicle ignition is on and the lift door is open.

An Interlock Override switch in the Driver's left switch panel enables the Driver to temporarily override the interlock system. An audible alarm sounds in the event of an interlock malfunction.

When used with the existing vehicle parking brake, the brake interlock uses the vehicle's service brake system to provide additional brake holding action.

**CAUTION** Use only DOT 5 brake fluid in the Hydraulic Interlock Brake system reservoir.

**WARNING** The brake interlock is a safety device and is not intended to be used as a parking brake. The Interlock system should never be used to stop the bus. Do not open the bus door(s) while the vehicle is in motion.

The following are decals along with WARNINGS located forward of the switch panel below the driver's side window, on All Americans with hydraulic brakes.

**Read Warnings and Operating Instructions prior to using.**



**690 Brake Lock**

**TO LOCK:**

1. Set parking brake
2. Move lock switch to ON position

**TO RELEASE:**

1. Move lock switch to OFF position
2. Release parking brake

**⚠ WARNING**

Serious injury or death can occur if these instructions are not followed.



Vehicle equipped with Brake Lock System. Operator must read and understand operating instructions before using vehicle. Brakes will release if ignition is turned off when Brake Lock is remotely activated. Do not use Brake Lock in place of original equipment parking brake. Always set parking brake and use wheel chocks and outriggers with Brake Lock. Do not use Brake Lock for overnight or prolonged parking. Release Brake Lock before moving vehicle. Brake Lock and warning circuit are disabled if battery power is lost or disconnected.

**⚠ WARNING**

Serious injury or death can occur if these instructions are not followed. Opening vehicle service door causes brakes to be applied. Vehicle equipped with Door/Brake Interlock. Operator must read and understand operating instructions before using vehicle. Brakes will release if ignition is turned off when Door/Brake is remotely activated. Do not use Door/Brake for overnight or prolonged parking. Close vehicle service door before moving vehicle. Door/Brake and warning circuit are disabled if battery power is lost or disconnected.



## Air Brakes

All Americans equipped with air brakes employ separate systems for the front and rear service brakes. A separate reservoir and air gauge is provided for each of these systems. A dual treadle valve is provided for operating the service brake system. In the event there is a failure in the air reservoir for the front brakes, the rear service brakes can still be applied using the treadle valve, since the two service brake systems operate independently. If there is a failure in the air reservoir for the rear service brake system, the front service brakes and the rear spring brakes can be applied through the treadle valve. This allows the operator to use a normal method of braking even though part of the system is malfunctioning. However, in the case of an air reservoir failure, the low air pressure warning buzzer will activate, indicating trouble, and the respective air gauge on the dash will show which system has lost air pressure. The bus must not be operated under those conditions, but repaired before continuing operation.

The rear spring brakes can also be controlled by a dash-mounted valve located on the lower portion of the instrument panel. The spring brakes cannot be fully released until the air reserve pressure is above 60 psi. These brakes are in the released position when the control valve is pushed in, and in the applied position when the control valve is out. In the event there is a loss in air pressure, the valve will automatically move to the brake applied position and cannot be released until the air reservoir pressure has been replenished.

### Air Brake/Throttle Interlock System (Optional)

All Americans equipped with air brakes may include an optional Brake/Throttle Interlock feature which, when active, automatically applies the service brake and disables the throttle when the vehicle ignition is on and the lift or entrance door is open.

A Brake Override switch in the Driver's left switch panel enables the Driver to temporarily override the interlock system.

**WARNING** *The brake interlock is a safety device and is not intended to be used as a parking brake. The Interlock system should never be used to stop the bus. Do not open the bus door(s) while the vehicle is in motion.*

### Parking

Use the dash mounted valve to apply the rear spring brake when parking the bus. When the parking brake is applied, and the ignition switch is ON, a dash-mounted yellow light labeled PARK will warn the driver that the brake is applied.

**CAUTION** *Do not attempt to move bus before spring brakes are released.*

### Draining Air Tanks

Condensation must be drained from the air tanks daily. To drain tanks properly, leave the drain cocks open until all air escapes and draining stops.



## HEATERS

Blue Bird heaters depend on engine generated heat to function. Heat from the engine is picked up by the engine coolant, which is pumped through the heater cores inside the bus, and then back into the engine. A typical heater inside the bus includes a heat exchanger coil, (core) and fans which move air across the coil. Air moving across the core picks up heat from the engine coolant and transfers it into the bus.

Satisfactory performance of the heaters is dependent upon:

- Adequate engine (coolant) temperature, which is controlled by the thermostat rating (which should never be higher than recommended by the engine manufacturer). Some All Americans feature optional shutters on the radiator that help to regulate engine coolant temperature.
- Coolant flow, which varies with engine speed can be increased, if necessary, with the use of an optional auxiliary water pump.
- Blower motors have multiple speeds and can be checked by operating the motors individually, while listening for variations in speed.

### Heater Operation

Be sure the engine radiator is full and all coolant flow valves are open. See charts on valve location.

**CAUTION** Do not leave the engine running while opening or closing valves.

Warm the engine to operating temperature, running at up to 1,800 rpm if possible, and then turn on the heater fans and the auxiliary water pump if so equipped.

During extremely cold weather, operating the heater fans will cause the engine temperature to drop noticeably as heat from the engine is transferred into the bus. Also, the engine will generate more heat as it works under load. When the engine reaches operating temperature, the driver can control heater blower speeds for optimal defrosting and overall passenger comfort.

### Control Panel Outlet Locations

The heater control panel is located on the dash to the right of the instruments. The indicated switches and levers control the motors and air outlets as shown.

The heater is located in the right front corner, forward of the entrance door. An optional auxiliary unit is located under the driver's seat. Electrical switches and mechanical diffusers control the volume and direction of airflow. The main heater has a three-speed control switch for manual low or high speed operation, and an

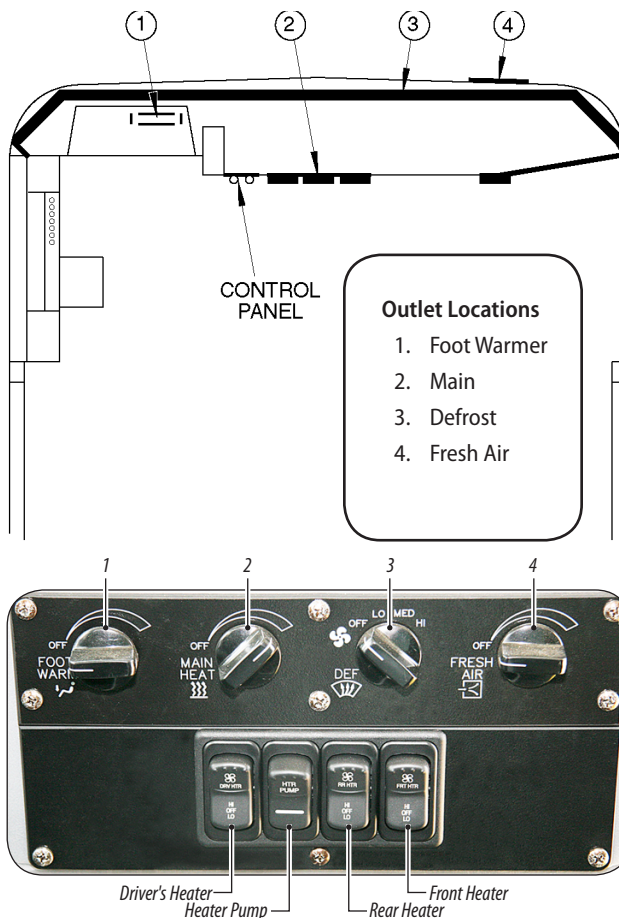



additional maximum output position for flash defrosting or extreme conditions. All the air from the main heater blower is directed to defrosting when the main outlet and foot warmer outlet are closed.

The Noise Suppression Switch turns off all heaters and radio to allow the driver to hear sounds outside the bus; for example, at a railroad crossing. When the switch is in the “on” position, neither the heater blowers nor the radio will operate.

## Defrosting

Windshield fogging and frosting is caused by warm, humid air coming into contact with a colder windshield, which causes the moisture in the air to condense and freeze if the windshield is cold enough. The warmer the windshield, the less moisture will condense. During initial warmup, the defroster blowers should be operated at low speed to preheat the inside of the windshield glass. If the defrosters are not turned on until after condensation starts, it is more difficult to heat the glass and drive moisture away.

As passengers are loaded, the moisture content of the air inside the bus increases. This moisture content tends to be lowered by opening the heater fresh air inlet. Conditions will be especially difficult when large passenger loads stay on board for extended periods of time, such as on a charter or over-the-road activity trip. Traveling at highway road speeds causes heat to dissipate through the windshield glass, and each passenger’s breath continually adds to the air’s moisture content. To reduce fogging, open the forward driver’s window slightly to let the moist air escape. *Fresh air control knob should be set to full fresh air position (counterclockwise) for defrosting/defogging operation.*

## Heater Defroster Location

The blower in the front main heater contributes to keeping the driver’s area glass clear of fog and frost. See OUTLET LOCATION diagram. For best results, fresh air should be flowing into the heater. To inspect the fresh air intake and make sure it is working properly, open the front access panel on the curbside side of bus.

## Driver / Passenger Comfort

When the windows are defrosted, the other openings can be set as necessary for comfort. The adjustable diffusers on the dash can be directed toward the driver and/or passengers as desired. The optional auxiliary unit under the driver’s seat has a two-speed electrical switch and it directs air upward for the driver’s left side and forward around the steering column area.

## Temperature Control

The temperature control knob varies the amount of engine coolant flowing through the heater system, this directly affects the temperature output of the heater. *Note: If the bus is equipped with an auxiliary fuel-fired heater, the temperature control knob must be set to the “Full Hot” (clockwise) position before the bus is switched off in order to function properly.*

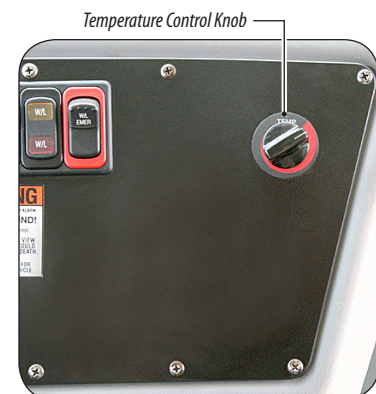

Located in front right switch panel

## Standard Heater Cut Off Valves

Valves are provided in the heater piping to permit isolation of the heating circuit from the engine coolant circuit. This is useful in case a leak occurs within the system, or to restrict the flow of hot water through the bus during warm weather.

When Valves No. 1 and No. 2 in the diagrams below are closed, engine coolant is prevented from circulating through the heaters. (This does not restrict circulation of the engine cooling circuit, so it is safe to operate the engine with the valves closed.)

**CAUTION** Do not operate auxiliary heater or auxiliary coolant pump with heater cutoff valves closed

Engine: Cummins ISB

VALVE NO.	LOCATION
1	AT ENGINE BLOCK
2	AT TRANSMISSION OIL COOLER

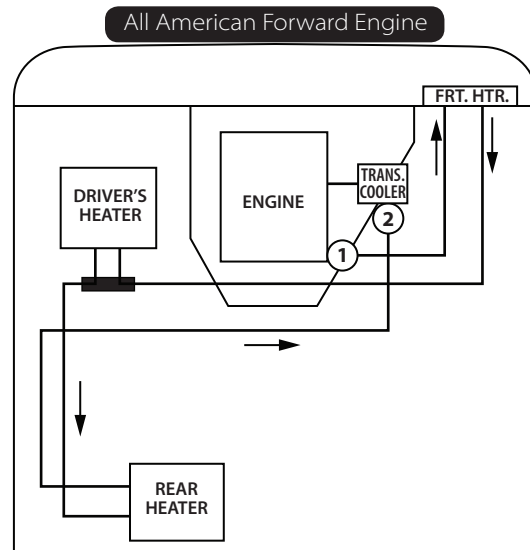
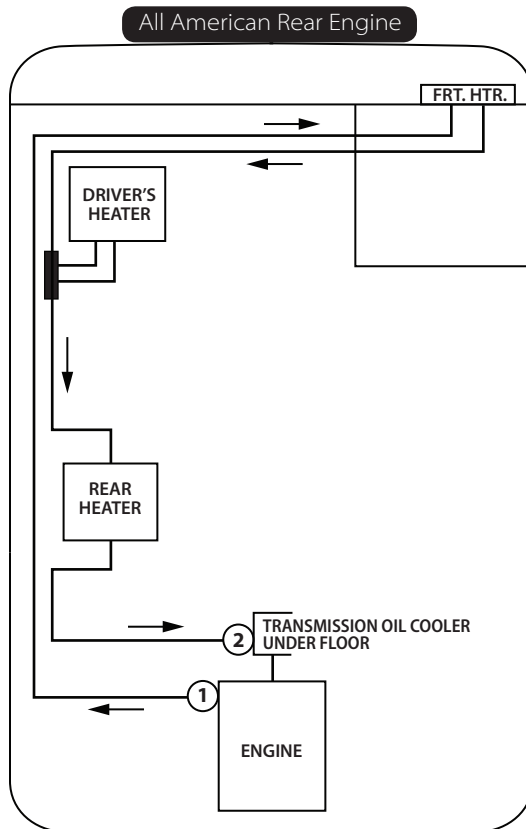



## CARE & MAINTENANCE

*Although in most transportation operations, maintenance tasks will be performed by service technicians, familiarity with the basic technical data in this section will enhance the Driver's overall understanding of the vehicle, and may serve as a convenient reference for service technicians rendering roadside assistance. This section also contains general cleaning and care guidelines. For thorough service information and procedures, refer to the All American Service Manual.*

Actual operating conditions must be considered and maintenance intervals adjusted accordingly. If at any time a system does not perform satisfactorily, corrective service should be performed at once. It is important that personnel attempting the repair or maintenance of this vehicle have access to, and a thorough knowledge of, the appropriate Blue Bird Service Manual.

## ELECTRICAL

**CAUTION** *Repair and/or modification of the electrical system, including adding components, should be referred to a trained, experienced technician.*

The following guideline must be observed when working on the vehicle electrical system. Be particularly cautious when adding components that they do not exceed the ability of the electrical system as designed and manufactured.

1. Disconnect the battery before beginning any repair or modification to the electrical system.

**WARNING** *Always disconnect the battery negative NEG (-) terminal first to avoid sparks/arcing.*

2. Use only the proper gauge wiring with high temperature insulation, compliant with SAE J-1128 (150° C).
3. Be certain any added component is fitted with adequate circuit protection, and that it does not exceed the capability of the electrical system as designed and manufactured.
4. Any "push on" type connectors must be insulated.
5. When installing or repairing wiring, always observe the following precautions:
  - Install clamps and ties to prevent chafing and contact with sharp edges.
  - Support wiring with insulated clamps at least every 18 inches (38 cm) where possible.
  - When the wiring must flex (i.e., when connected to moving parts like the engine), be certain to provide adequate slack loops.
  - Be certain to provide adequate length to prevent tension on the wires or connectors.
  - Be certain wiring is secured at least 4 inches (10 cm) from high heat sources (i.e., engine, exhaust system, transmission etc.).
  - Always use an appropriate grommet when the wires must pass through a hole.
  - Protect all "hot" primary and ignition wires with an appropriate loom.
  - Never route a wire in contact with a fuel line.
  - Do not route wires in contact with plastic components.



6. Always be certain that all ground connections are replaced when wiring is performed on engine components.
7. Do not splice into existing wires when adding components. Run new wiring full length to an appropriate source connection and provide proper circuit protection.
8. When accessories are added, check installation guides very carefully. You may need to install a control relay for proper operation.
  - Use a blank circuit breaker in the electrical panel if possible. If the accessory must be on during cranking, connect directly to the "hot bar". Always install the appropriate sized circuit protection device in the circuit.
9. Always install insulating rubber boots on 6 gauge "hot" or larger connections whether to the alternator, ammeter shunt, or another junction.

**WARNING** To avoid sparks and arcing, always connect the negative NEG (-) battery terminal last.

#### *Wiring Circuit Color Code Major Circuits*

FUNCTION	COLOR
LEFT DIRECTIONAL LIGHT	YELLOW
RIGHT DIRECTIONAL LIGHT	DK.GREEN
STOP LIGHTS	RED
BACKUP LIGHTS	BLUE
TAILLIGHTS	BROWN
GROUND	WHITE
IGNITION FEED, PRIMARY FEED	BLACK

Refer to the appropriate wiring diagram for wire colors for other circuits.

**Interior Lights**

<i>Lamp Description</i>	<i>Trade Name</i>	<i>Trade No.</i>	<i>Color</i>	<i>Bulb No.</i>
Dome	Weldon™	8020	(Standard)	922
Stepwell	Arrow™	35		67
	Soundoff™	SWLT		LED Non-Replaceable
Emergency Door Light	Soundoff™	140		LED Non-Replaceable
Switch Panel Pilots	Eaton™	NGR		53
Switch Panel Illumination		1314962		53

**Exterior Lights**

Directional	CRS™	103		1157
	Soundoff™	756		LED Non-Replaceable
Warning Light	Soundoff™	756IB		LED Non-Replaceable
Warning Light Halogen	CRS™	102		H3
Cluster and Marker	Weldon™	5210		LED Non-Replaceable
Side Directional	Soundoff™	MTY		LED Non-Replaceable
	CRS™	104		1157
Stop-Tail 7 inch	CRS™	103		1157
	Soundoff™	756		LED Non-Replaceable
Stop-Tail 4 inch	CRS™	103		1156
	Soundoff™	R4		LED Non-Replaceable
Backup	CRS™	103		1156
	Soundoff™	R4		LED Non-Replaceable
Tag	CRS™	104		168
	CRS™	104		LED Non-Replaceable
Destination Sign				89
School Bus Sign				TS93



### Doran Warning Light Monitor

The Doran Monitor™ is a current sensing device. If current is flowing through one of the bus lamp circuits, the monitor senses it and illuminates the corresponding monitor light emitting diode (LED). When a lamp burns out, current flow through the circuit stops and the corresponding LED on the monitor does not illuminate, indicating the outside lamp is not functioning. The Doran™ Monitor is located in the bulkhead over the windshield and slightly to the left of the driver.

Warning lights are such an essential safety feature, it is important to know when they are not working properly. This is the function of the Doran monitor. Its display is a schematic of the lights as they appear outside the bus. It continuously monitors the current in each lamp. If current is flowing through a particular bus lamp circuit (i.e., the light is on), the monitor senses this and lights the corresponding monitor bulb. If the bus lamp burns out, current ceases and the corresponding monitor bulb goes out, indicating a fault. Once the defective lamp is replaced, and the warning lights are working normally again, this also should be shown by the monitor.

The Doran monitor is a reliable, long-life device, but as with most electrical instruments, it can be overheated and damaged if an overload occurs in a bus light. Such overloads can exist if a bus light circuit becomes shorted, forcing current through a coil in the monitor that exceeds the coil's rated capacity. Short circuits can occur if improper connections are made during installations, bus repairs, etc. If the monitor has an optional thermistor overload protection, the tail light circuits are overload-protected. (Thermistors are located on the bottom of the component side of the printed circuit board.)

If the Doran monitor is not working properly, see **Troubleshooting** for units equipped with incandescent lighting only. See **Calibration** for units equipped with LED lighting.

### Doran Troubleshooting

**The Doran Warning Light Monitor™ does not display any indicator LEDs:**

1. An overload situation has created an open circuit. Check the system circuit protection.
2. An overload or physical damage has burned or broken a conductor on the printed circuit board:
  - Extra lights have been added to the circuit; i.e., trailer lights, etc.:
  - Remove the extra lights from the circuit
  - Replace the damaged printed circuit board
  - Excessive vibration or abuse has resulted in a damaged monitor. Replace the printed circuit board

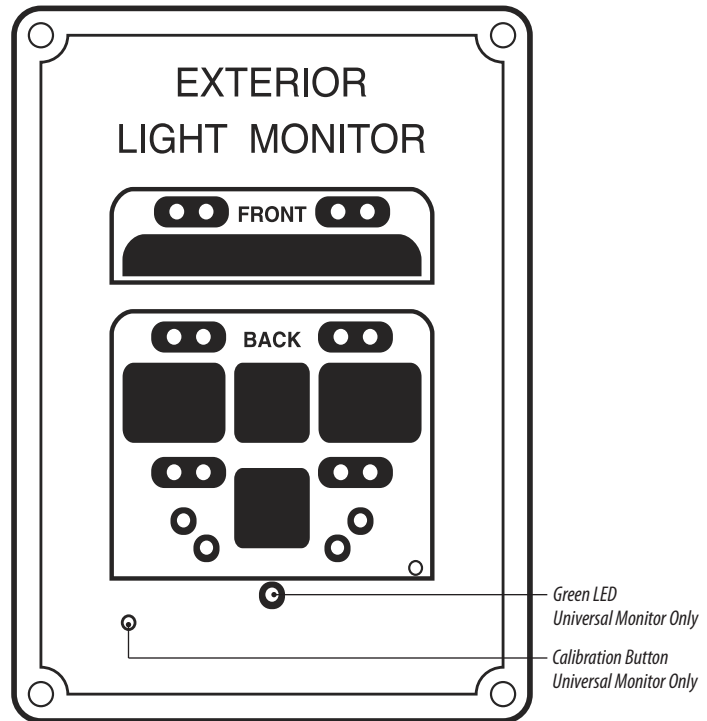

Green LED  
Universal Monitor Only

Calibration Button  
Universal Monitor Only

**A particular LED on the Doran Warning Light Monitor™ does not display, but the bus running lights are operating properly:**

1. There is an open coil in the monitor
  - The coil is burned due to an overload. Replace the coil kit.
  - A solder joint has weakened (a cold solder joint). Flow new solder on the connection.
  - The reed switch has failed. The reed has broken or the contacts have failed. Replace the reed switch kit.
  - The printed circuit board is broken or burned. Replace the printed circuit board.
  - There is an open in the LED circuit. Replace the LED.

**A monitor LED indicator is on but, the bus running light indicated is not operating, or the bus running light switch is in the off position and the monitor indicates the running lights are operating:**

- Replace the coil and reed switch kit.

**Neither the bus running lights nor the Doran Warning Light Monitor™ operate properly:**

1. The running light bulb may be burned out. Replace the light bulb.
2. The overload thermistor has protected the circuit from overload. Remove the overload condition.
  - A short
  - Incorrect light bulb/s
  - Extra lights; i.e., trailer lights, etc.

**Doran Calibration** *(Universal Monitor Only)*

To self calibrate the monitor, ALL monitored lights must be in working order. For faster calibration, the operator may turn on as many exterior lights as possible at the start of the procedure. The operator will be required to activate these lights during the calibration procedure. Operator may begin with the tail/head lights on, hazard lights (for the turn signals), and the amber warning lights flashing (door closed).

1. Turn on ignition and start engine – Engine is running to assure proper voltage for operation and calibration. The GREEN LED voltage indicator at the bottom center of the monitor **MUST BE ILLUMINATED** indicating the voltage is within limits for proper operation. Before beginning calibration, allow time for the voltage to stabilize to its normal running voltage. After cranking the engine the battery voltage may be lower than normal. Allow time for the battery to recharge.
2. When the ignition is turned on, all LED's on monitor will be enabled for a few seconds to verify that all LED's are working.
3. To enter the calibration mode, press and hold the calibrate button through the face plate hole for longer than two (2) seconds. This button/hole may be found located at the bottom left corner of the bus image on the monitor face plate. The first light to calibrate will begin flashing when the unit enters calibration mode. You may use an object such as an allen wrench or paper clip to activate the switch.

**CAUTION** *Do not attempt to check a light emitting diode (LED) with an ohmmeter. Some digital volt meters (DVM) have a diode checking position, which is acceptable to test LEDs. Any repair of the Doran Warning Light Monitor™ should be referred to a qualified technician.*



4. The unit will begin calibrating each light in a sequence. Each light tested must be active at the time of the calibration. As each light is calibrated, the matching monitor LED will flash. Operator shall activate (if not active) the bus light corresponding to the flashing LED. The sequence is as follows:
  - a. Left turn signal – switch on
  - b. Right turn signal – switch on
  - c. Stop lights (left, then right side 7" will flash) – press brake pedal
  - d. Tail light (left, then right side 4" will flash) – switch on (brakes off)
  - e. Backup lights – press brake/clutch and engage reverse
  - f. Each Amber warning light – switch on with door closed
  - g. Each Red warning light – open door
5. Calibrated lights are indicated by the corresponding LED staying illuminated on the monitor. The unit continues to loop through the sequence flashing the un-calibrated lights until all lights are calibrated.
6. When all LED's are illuminated, turn off ignition to complete the calibration.

### Circuit Breakers

The electrical system is protected by fuses as standard, circuit breakers are optional. Circuit breakers or fuses are located in a side mounted electrical box below the driver's window. If a current overload or "short" should occur in any body circuit, it will trip the circuit breaker. If a short occurs and the circuit breaker breaks, the circuit breaker will reset when the element cools; usually in about 15 seconds. A short may be indicated by blinking lights or fluctuating gauges. The shorted circuit should be corrected immediately. Refer to body or chassis master wiring diagrams. A complete wiring diagram is available from Blue Bird Corporation Technical Publications.

To access the electrical panel, open the access door located outside the bus below the driver's window. A reference decal is provided on the inside of the access panel. Use of appropriate amperage circuit breakers is required.

### ACCESSORIES AND ADDED COMPONENTS

When adding accessories and aftermarket components, it is important to consider the results very carefully.

- Does the component over burden the electrical system?
- Does the accessory interfere with any of the driver's controls?
- Does the accessory interfere with the driver's field of vision?
- Heavy components and accessories must be mounted near, or below, the floor line to avoid raising the vertical center of gravity.
- Will passenger safety and comfort be adversely affected?

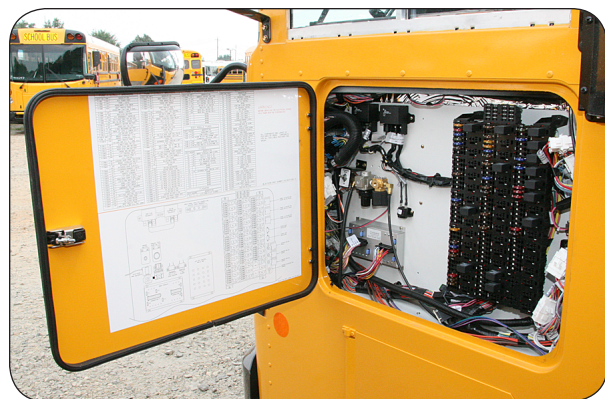

## *DOOR ADJUSTMENT & LUBRICATION*

Maintenance procedures for entrance doors must be performed by qualified technicians at intervals of one month or 1,000 miles, whichever occurs first.

### **Continuing Maintenance Requirements**

- Keep working parts of control tightened.
- Lubricate all working parts periodically, including hinges and overhead controls.
- Repair or replace worn seals.
- Maintain proper door opening and closing adjustment.

### **Outward Opening Door Adjustment**

Outward Opening Doors are mounted in a prefabricated framework, which eliminates the effect of body construction variations on door and seal operation. Doors are suspended completely on sealed ball bearings located at the top corners of the framework, inside the body. The interlink connection between the doors is a single assembly with oppositely threaded, spherical bearing rod end connectors at each end, providing simple link length adjustment without disassembly. Loosen the lock nut, turn the tube, and retighten the nut when satisfactorily adjusted. The geometry of the mechanical link between the doors causes the rear door to close well ahead of the front door, so that the front nosing seal rubber always overlaps the rear. Oil impregnated bronze bearings in the lower corners of the framework serve as pivots (not supports). All controls and mechanisms and the complete lower step tread are sealed inside the bus and out of the weather when the door is closed.

### **Outward Opening (Air Powered) Adjustment**

The pneumatic actuator is a cylinder connected to a lever on each door, located inside the header cover. An interconnecting link between the doors controls the operation sequence. A safety release valve is located over the door. Air switches inside the header cover operate Stepwell lights. A two way manually operated valve manages the driver's door control. Air pressure holds the door either open or closed, depending upon the position of that valve. The operation speed is adjustable by use of flow control valves located on the actuator.



## Jackknife Door Adjustment

1. Loosen the roller bracket at the top of the rear door.
2. Adjust the length of rod (between the door control and the door) and the location of the rod end bracket on the door for proper open and closed position.
  - 2.1 Lengthen the rod if the door opens too far and does not close against the top seal.
  - 2.2 Shorten the rod if the door closes too hard and does not open far enough.
  - 2.3 Move the rod end bracket forward if the door does not close against the seal and does not open far enough.
  - 2.4 Move the rod end bracket rearward if the door opens and closes too far.
3. Attach the roller bracket to the rear door and adjust.
  - If the rear door hangs in the track when starting to close the door, move the bracket to the rear.
  - If the rear door does not open to the front enough, move the roller forward.
4. Perform the following adjustments and maintenance for ease of operation. The top of door should be approximately  $\frac{3}{8}$  inch below the door header.
  - 4.1 Move the door upwards so that the rubber door sweeps do not drag on the stepwell treads. Adjust door height by loosening the bolts and nuts that attach the front door panel to the front hinge. Holes in the hinge are slotted. This permits vertical adjustment of the door.
  - 4.2 Ensure that the top edge of the door nosing rubber does not drag on the doorstop header rubber. Remove the first three upper screws in the inner and outer nosing rubber retainer strips and force the nosing rubber downwards. Replace the screws after the rubber nosing has been adjusted.

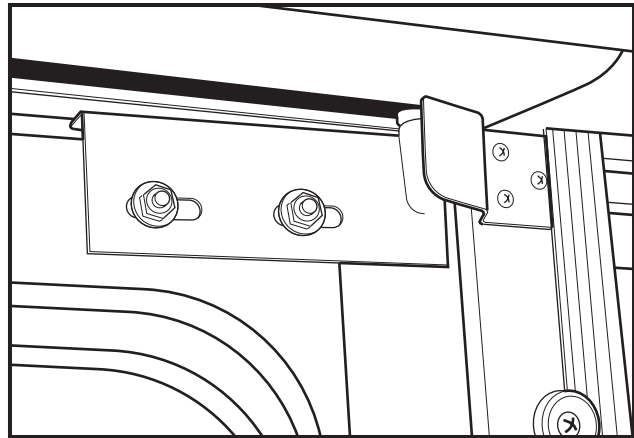

Roller Bracket

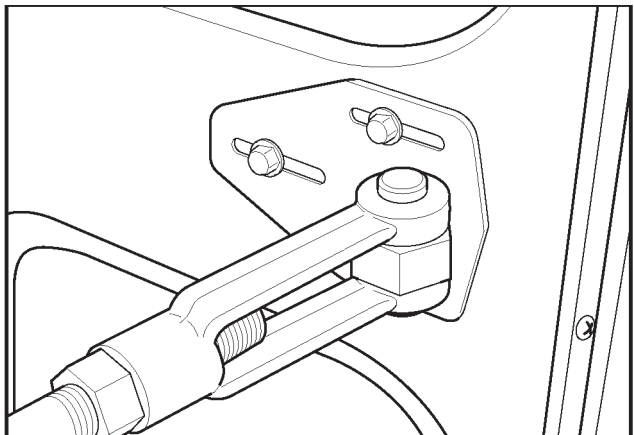

Rod End Bracket

- 4.3 The rear upper corner of the rear door panel should not drag on the rubber door stop on the header. To provide the required clearance, move the door roller bracket towards the rear of the bus. This will effectively move the door panel away from the doorstop rubber.
- 4.4 Clean the stepwell rubber treads and lower the door rubber sweeps regularly. Cleaning these surfaces will reduce friction as the door is operated.
5. Ensure that the door control rod end bracket is mounted squarely on the door. If it is not, the yoke end pivot pin will bind. Adjust it by loosening screws and tightening after the bracket has been squared up.
6. Inspect the pivot nut on the rod end bracket for burrs or other surface irregularities. Grind or file the pivot nut so that its upper and lower surface is smooth.
7. Lubricate the door hinge pin with a spray type lubricant (LPS No. 1, or equivalent). Lubricant should penetrate behind each hinge lug. Door hinges will operate quietly if properly lubricated.

### **Power Jackknife Door Adjustment**

The following adjustments and lubrications should be performed on the power jackknife door to ensure its proper operation.

1. Lubricate the center hinge with LPS No. 1, or equivalent, lubricant.
2. Adjust the actuator yoke so when the cylinder rod is fully extended, the door is not forced beyond its normal stopping point at the front stepwell band. Adjust the actuator mounting bracket when required. Improper adjustment of the cylinder yoke can cause premature failure of door components.
3. Adjust the switch striker plate on the actuator to prevent binding in the closed position.
4. Ensure that the roller bracket is installed squarely on the rear door panel.
5. Ensure that the center hinge barrel is not binding against the outer skin of the rear door panel.
6. Adjust opening and closing speed of the door with the valves located on cylinder. Air pressure should be at normal operating range (100 to 125 psi) during this adjustment.
7. Torque the upper pivot bracket retaining screw at the lever assembly to 20 Ft. lbs. (27 N·m).

### **Sliding Bolt Vandal Lock**

Lubricate the sliding bolt mechanism of the Sliding Bolt Vandal Lock every six months or 6,000 miles (whichever occurs first). Use LPS-1 spray lubricant, or equivalent.



### Security Lock Lubrication (Outward Opening Door)

If the Outward Opening Door Security Lock becomes difficult to operate, remove the access plate on the inner door panel and lubricate with No. 2 lithium grease. (Access plate shown removed in illustration.)

Lubricate security locks every six months or 6,000 miles, whichever occurs first. Using LPS-1 or Apply™ lubricant (or equivalent), spray into the bushing and shaft in the center at the base of the lock handle. Also spray lubricant into key lock mechanism. Rotate the lock handle to ensure smooth operation.

Manual Security Lock (interior)

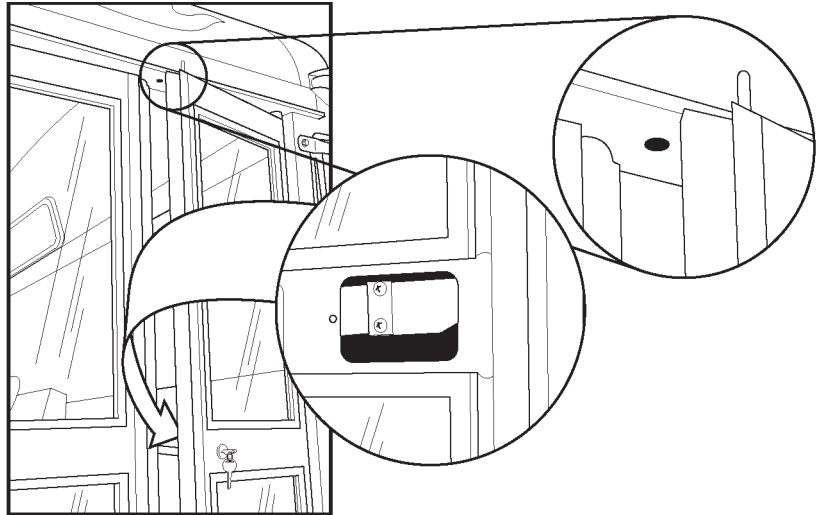

### Access Doors

Periodic maintenance is necessary to prolong the life of access door latches, locks, and hinges. Each week, clean and inspect the door hinges and latch mechanisms. Clean with a nonabrasive degreaser or cleanser as required. Every three months, lubricate with either a graphite-type lubricant or a spray-type lubricant such as LPS. Following is a list of access doors for which these maintenance procedures are recommended:

- Battery Compartment Door
- Luggage Compartment Door
- Tire Compartment Door
- Fuel Fill Door
- Radiator Fill Door
- Side Electrical Panel Door
- Left and Right Hand Front Access Doors

Glove compartment and emergency equipment doors should be inspected on a daily basis. Open and close to ensure proper operation. If necessary, follow the same lubrication procedure as outlined above.

## SEATING CARE

### Seat Belt Inspection And Maintenance

Inspect seat belts and their attachments, at least weekly. Check seat belt buckles and adjustability to ensure proper operation. If necessary, lubricate the buckle with a graphite lubricant. When a buckle is found to be inoperable, replace it immediately. If there are any defects in the webbing (i.e., torn or frayed), the seat belt must be replaced immediately to ensure passenger safety. Hand wash webbing with warm water and mild soap. Rinse thoroughly and dry in the shade. Do not bleach or re-dye, because such processing may severely weaken the assembly.

**WARNING** Do not bleach or dye the webbing. Such processing may severely weaken the assembly.

### Seat Inspection And Maintenance

Blue Bird seats are built to meet Federal Motor Vehicle Safety Standards. In order to provide a greater margin of safety during passenger transportation, follow these guidelines:

- Inspect and, if necessary, tighten seat leg and wall side mounting bolts every 90 days.
- Inspect and, if necessary, tighten cushion attachments weekly.
- Inspect upholstery for cuts and tears every 90 days. If upholstery is torn, remove it by taking out the staples at the bottom front of seat back or bottom of cushion and pulling the cover away. For installation of new cover, reverse this procedure.
- School bus seats are equipped with a special foam back pad. If the pad becomes damaged, it should be replaced with an approved part. Aftermarket suppliers should be checked for compliance with Federal standards.

### DRIVER'S SEAT LUBRICATION

Moving parts of the driver's seat require lubrication for ease of operation, as well as longevity of the seat and prevention of excessive wear.

Currently available is white lithium-based grease in an aerosol can. It gives excellent coverage when carefully directed into moving part joints. The very light coating of lubrication provided by aerosol-carried solvent-type solution works very well for penetrating into a joint and cleaning away dirt, but it should only be depended on for lubrication if it is applied frequently. A common 10W30 or 10W40 motor oil will provide good lubrication.

Remember that all moving part joints, tilt pivots, slide forward/back adjustment, and vertical motion pivots (four in all) require lubrication. This should be done every six months or 6,000 miles, whichever occurs first. The use of lithium-based grease in aerosol form is recommended.



## SEAT CARE AND CLEANING

It is imperative that the interior of the bus be kept clean; seats are an important part of this maintenance. Regular cleaning and care will prolong the life of the seats and improve the general appearance of the bus.

**Everyday dirt and soil.** Most everyday soil and dirt may be removed with a soap and water solution. If the stain is persistent, a stiff bristle brush may be used. Fabric covered seats should be rinsed with clean water after the stain is removed.

**Paint, tar, and asphalt.** Remove the stain immediately using a damp cloth and kerosene. Rub gently, using small strokes. Rinse thoroughly. This type of stain may become permanent if not cleaned immediately.

**Nail polish and lacquer based stains.** Soak up as much as possible with dry cloth immediately. Any remaining stain may be removed with a non-flammable cleaning fluid such as "Tuff Stuff™" or "Armor All™" cleanser. Rinse thoroughly with clean water.

**Gum, grease, and shoe polish.** Remove as much as possible immediately. If left for any length of time, shoe polish will stain permanently. Clean any remaining stain with "Tuff Stuff™" or "Armor All™" cleanser.

**Ink.** Remove stain immediately using a damp cloth and alcohol.

## SEAT CUSHION REMOVAL AND INSTALLATION—DOT SEATS & SEAT BELT SEATS

**WARNING** *If seat cushions are removed for maintenance, they must be reinstalled using the following instructions. Failure to comply with these instructions could result in injury from unattached seat cushions in the event of an accident.*

1. To remove the seat cushion. Loosen and remove two Torx screws from the flanges at the front of the seat frame.
2. Lift the forward edge of the cushion 2 to 3 inches (5 to 8 cm) and pull forward.
3. To reinstall the seat cushion reverse the above procedure.

### TRACK MOUNTED PASSENGER SEATS

If your bus is equipped with track mounted passenger seats and you relocate the seats or remove them to accommodate wheelchairs, you must follow rules of spacing and placement to comply with Federal Motor Vehicle Safety Standard 222 "School Bus Passenger Seating and Crash Protection" and Federal Motor Vehicle Safety Standard 217 "Bus Window Retention and Release". A decal printed with these rules (as shown below) is installed on the interior body panel above the windshield.

**WARNING** *The federal rules governing passenger seating, spacing, and placement are explicit. When the seats are moved, the entity moving or re-arranging the seating assumes responsibility for compliance with FMVSS 222 "School Bus Passenger Seating and Crash Protection" and FMVSS 217, "Bus Window Retention and Release".*

All passenger seats must have a seat or barrier in front of it to provide compartmentalization required by Federal Motor Vehicle Safety Standards. As you reconfigure your bus, you may need additional barriers, which are available from Blue Bird Corporation Service Parts.

### Blue Bird Track Mounted Seats

01943760 BB

**FEDERAL STANDARDS REQUIRE THAT ALL PASSENGER SEATS MUST BE LOCATED REARWARD OF A SEAT OR BARRIER OF AT LEAST THE SAME WIDTH. SEATS MUST BE INSTALLED BETWEEN MINIMUM AND MAXIMUM SPACING AS LISTED BELOW IN ORDER TO MEET FMVSS 222 REQUIREMENTS.**

<p style="font-size: x-small;">A CHILD RESTRAINT DECAL MUST BE LOCATED ADJACENT TO ALL LATCH SEATS</p> <p style="font-size: x-small;">SEAT: 27.00 MIN. 31.00 MAX. BARRIER: 11.00 MIN. 16.00 MAX.</p> <p style="text-align: center; font-weight: bold;">SEAT SPACING MEASURED AT AISLE</p>	<p style="font-size: x-small;">12 (MIN) 24 (MIN)</p> <p style="font-size: x-small;">REAR EMERGENCY DOOR CLEARANCE: A CLEAR ACCESS AREA OF SIZE SHOWN WITH HEIGHT OF 45 IN. IS REQUIRED TO MEET CMVSS 217 OR FMVSS 217.</p>	<p style="font-size: x-small;">12.00 (MIN)</p> <p style="text-align: center; font-weight: bold;">SIDE EMERGENCY DOOR CLEAR AISLE</p>	<p style="font-size: x-small;">2.00 (MIN)</p> <p style="font-size: x-small;">FOR 74 HEADROOM ONLY EMERGENCY EXIT RELEASE CLEARANCE</p>
---	--	--	--

**C E White, Child Restraint, Track Mounted Seats**

00062317 CEV CR

FEDERAL STANDARDS REQUIRE THAT ALL PASSENGER SEATS MUST BE LOCATED REARWARD OF A SEAT OR BARRIER OF AT LEAST THE SAME WIDTH. SEATS MUST BE INSTALLED BETWEEN MINIMUM AND MAXIMUM SPACING AS LISTED BELOW IN ORDER TO MEET FMVSS 222 REQUIREMENTS.

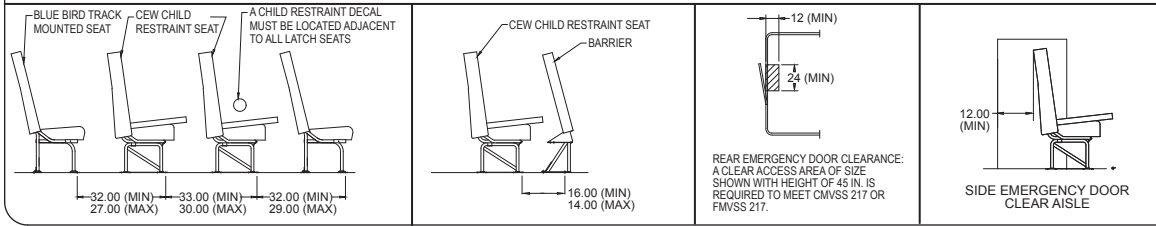

Labels in diagram: BLUE BIRD TRACK MOUNTED SEAT, CEW CHILD RESTRAINT SEAT, A CHILD RESTRAINT DECAL MUST BE LOCATED ADJACENT TO ALL LATCH SEATS, CEW CHILD RESTRAINT SEAT, BARRIER.

Dimensions: 32.00 (MIN) 27.00 (MAX), 33.00 (MIN) 30.00 (MAX), 32.00 (MIN) 29.00 (MAX), 16.00 (MIN) 14.00 (MAX), 12 (MIN), 24 (MIN), 12.00 (MIN).

REAR EMERGENCY DOOR CLEARANCE: A CLEAR ACCESS AREA OF SIZE SHOWN WITH HEIGHT OF 45 IN. IS REQUIRED TO MEET CMVSS 217 OR FMVSS 217.

SIDE EMERGENCY DOOR CLEAR AISLE

**C E White Student Safety Seat, and C E White Student Safety Seat Child Restraint, Track Mounted Seats**

00062639 CEV SSS\_SSSCR

FEDERAL STANDARDS REQUIRE THAT ALL PASSENGER SEATS MUST BE LOCATED REARWARD OF A SEAT OR BARRIER OF AT LEAST THE SAME WIDTH. SEATS MUST BE INSTALLED BETWEEN MINIMUM AND MAXIMUM SPACING AS LISTED BELOW IN ORDER TO MEET FMVSS 222 REQUIREMENTS.

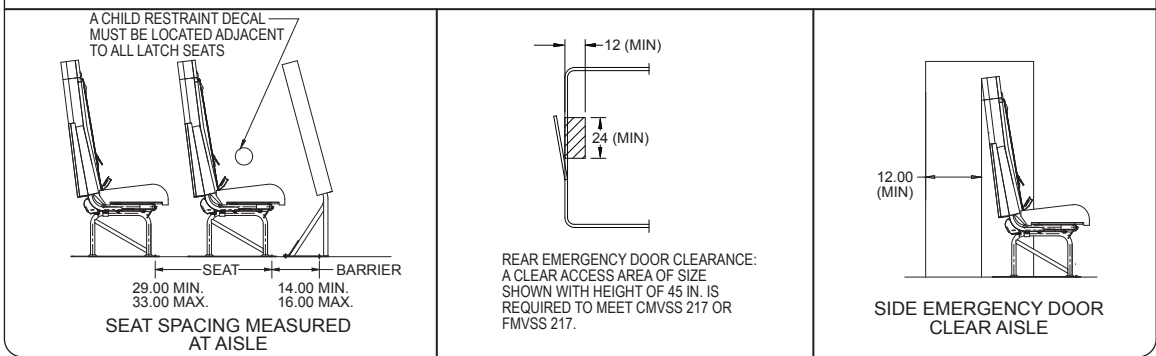

Labels in diagram: A CHILD RESTRAINT DECAL MUST BE LOCATED ADJACENT TO ALL LATCH SEATS, SEAT, BARRIER.

Dimensions: 29.00 MIN. 33.00 MAX., 14.00 MIN. 16.00 MAX., 12 (MIN), 24 (MIN), 12.00 (MIN).

REAR EMERGENCY DOOR CLEARANCE: A CLEAR ACCESS AREA OF SIZE SHOWN WITH HEIGHT OF 45 IN. IS REQUIRED TO MEET CMVSS 217 OR FMVSS 217.

SIDE EMERGENCY DOOR CLEAR AISLE

SEAT SPACING MEASURED AT AISLE

## SIGNS & SIGNALS

### Stop Arms

Stop arms are required on Blue Bird All American school buses by, and in accordance with, Federal Motor Vehicle Safety Standard 131. Stop arm assemblies are purchased as a kit to meet state requirements. The stop arm is located on the left-hand side of the body under the driver's window. A manual switch on the switch panel most commonly operates stop arms.

For pneumatically operated stop arms, the manual switch activates an electric solenoid valve controlling the flow of air. Optionally, the solenoid valve may be activated by the warning lamp system. This system is operated by the air system on the chassis. No special preventive maintenance procedures are required with these systems; however, the air pressure may occasionally require adjustment to ensure proper opening and closing of the stop arm. The air regulator is accessible through the outside electrical panel door under the driver's window. To regulate the air pressure, remove the wire retaining clip below the regulator knob and pull the red lock ring. Turn the knob counterclockwise to decrease the pressure, and then slowly increase the pressure (turn knob clockwise) until the stop arm hinge is extended to approximately 90°. Lock the knob into position by pushing in the red lock ring and installing the wire retaining clip.

Electrically operated stop arms may be activated by a manual switch or, optionally, by the warning lamp system.

The "STOP" sign must extend, and if equipped with lights, the lights must be operating any time the red lights of the warning light system are flashing. For state-designed warning light/stop arm systems which allow the stop arm to withdraw while warning lights are operating, an audible alarm sounds to alert the driver of the condition.

### Monthly Maintenance

- Oil the dual action breakaway hinge at its pivot points with a high performance, penetrating lubricant. Tri-Flow™ (duPont™) with Teflon™ is recommended.
- Check that the breakaway portion of hinge is freely movable.
- Check that fasteners are secure.

### Quarterly Maintenance

- Perform the "Monthly" procedures, above.
- Remove front and rear covers of base and check that fasteners are secure.

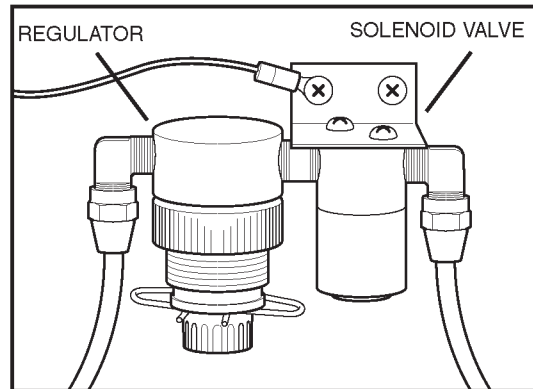



## Destination Signs

### Hinged Sign Front

Mounted on the outside of the front roof cap, with internal control for changing the display. Periodically lubricate hinges and lever assembly with lightweight lubricating oil.

### Hinged Sign Rear

Mounted on the outside of the rear roof cap, manually changed from outside. Periodically lubricate hinges with lightweight lubricating oil.

### One Station Lighted Curtain

Replace bulbs as needed. Because of vibration, the curtain can loosen. To tighten the curtain, loosen the bolts, pull the curtain taught and then tighten the bolts.

### Roller Destination Sign with Lighted Curtain

Replace bulbs as needed. Curtain may occasionally require same adjustment as One Station Sign. Periodically lubricate the roller gears with light grease, such as White Lube™. Lubricate the hinges on the access door with lightweight lubricating oil. To change the display, turn the crank located on the front, upper, inner panel above the windshield.

### Two Station Sign

Front lighted with lettering on both sides. Lubricate the interior door hinge on the front, upper, inner panel with lightweight lubricating oil.

### Lighted "School Bus" Sign

Back lighted yellow Plexiglas™ sign. Replace bulbs as needed. Lubricate the interior door hinge on the front, upper, inner panel with lightweight lubricating oil.

## ENGINE & RUNNING GEAR

### Air Intake System Inspection

Intake air must be filtered to prevent dirt and debris from entering the engine and causing premature wear. Air intake piping should be checked daily, as should charge-air piping and engine air cleaner service indicator, if equipped. Repair any leaks in the system before operating the bus. Never operate the engine without an air cleaner or with disconnected or loose piping.

#### Intake Air Restriction Indicator

Some engines are equipped with a gauge which displays the difference in air pressure before and after the air cleaner. As the air cleaner element becomes dirty, the pressure differential rises. If your engine is equipped with a different type of service indicator, follow the manufacturer's recommendations to service the indicator.

**CAUTION** *Leaks in the intake system will prevent the Air Restriction Indicator from reading accurately. Always check the piping for leaks, especially between the indicator and the engine intake.*

**Maximum intake restriction (clean air filter element):** 10.0 inches water (254 mm)

**Maximum intake restriction (dirty air filter element):** 25.0 inches water (635 mm)

**Cummins.** Replace the engine air cleaner every 12 months, or when the air cleaner service indicator shows restriction of 25 inches of water. Do not rely completely on the restriction indicator. A leak in the system will prevent the restriction indicator from operating properly. Always look at the piping to ensure there are no leaks.

#### Air Intake Piping

Inspect the intake piping daily for wear points and damage to piping, loose clamps, or punctures that can cause damage to the engine. Replace damaged pipes, and tighten loose clamps; replace if necessary, to prevent the air system from leaking. Check for corrosion under the clamps and hoses of the intake system piping. Corrosion can allow corrosive products and dirt to enter the intake system. Disassemble and clean as required.

#### Charge Air Piping

Inspect the charge air piping and hoses daily for holes, cracks, or loose connections. Tighten the hose clamps as necessary.

#### Charge-Air Cooler (CAC) Maintenance

Check this system every 3 months or 7,500 miles. Inspect the charge-air cooler (CAC) for dirt and debris blocking the fins. Check for cracks, holes, or other damage. If damage is found, refer to your Blue Bird Dealer.

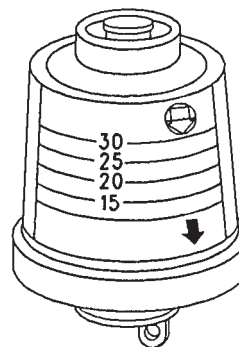



## Engine Cooling System

In today's modern engine designs, accurate maintenance of the cooling system is critically important to engine life. Simply maintaining coolant level and performing occasional coolant changes does not adequately ensure that the cooling system is healthy. The chemical balance of engine coolant must always be correct. This requires diligent adherence to the engine manufacturer's coolant specifications, maintenance schedules, and procedures. Accurate coolant system maintenance records should be kept.

The engine coolant level in the reservoir should be checked daily as a part of routine pre-trip inspection. But whenever the coolant level is low, it must be replenished with only pre-mixed coolant of the same type and brand installed. Never top off coolant with plain water.

Careful pre-trip inspection and a program of routine maintenance checks of the condition of the cooling system by service technicians should ensure against enroute emergencies such as worn hoses or loose clamps resulting in coolant loss. In the case of such an emergency, however, if anything other than original premixed coolant is added in order to allow the bus to proceed to a service facility, the coolant system must be completely drained, flushed, and properly refilled with approved coolant before being returned to routine service. Any enroute event requiring topping off of the coolant should be reported to service personnel responsible for maintenance of the bus.

**WARNING** *Exercise extreme care when removing the cap from the engine coolant reservoir. Always allow time for the engine to cool before removing the cap. The pressurized coolant may be very hot and can spray out, causing serious burn injuries.*

### Coolant Types

Engine coolant is generically divided between two types; "standard" and "long-life" (or "extended-life"). Extended-life coolants generally allow longer intervals between coolant changes (sometimes requiring additives to be added near the midpoint of their service life, and/or for special testing to be performed at certain intervals). Engine manufacturers, however, differ somewhat in regards to specifications for coolants which they recognize as "long-life" when used in their respective engines.

Blue Bird buses are delivered from the factory with one of two types of coolant. The standard coolant is Fleetguard Fleetcool EX 50/50 premix, which is red in color. This coolant is considered standard life when installed in Cummins engines.

Cummins equipped buses purchased with an extended life coolant option have been filled with Fleetguard ES Compleat OAT 60/40 premix, which is red in color.

Blue Bird installs a decal on or near the deaeration tank filler which state the type of coolant installed at the factory. The decal states the approved premixed coolant and coolant manufacturer's part number for one gallon quantities. The decal also lists the manufacturer's part number for the concentrate which is approved for mixing with the premix for stronger glycol concentration. Another decal near the fill neck indicates warnings for the service technician.

**CAUTION** *When replenishing or replacing coolant, only use coolant of the same type already installed. Never mix coolants of different color, type, or brand. Plain water is corrosive at engine operating temperatures. Never add plain water to the system. When using concentrated coolant to raise the glycol concentration for extreme temperature environments, Blue Bird recommends only mixing the concentrate with pre-mixed coolant of the same type; not mixing with water.*

### Coolant Testing and Replacement

Each engine manufacturer has its own specific requirements for coolant testing and maintenance. Therefore, refer to the engine Operator's Manual for your bus and follow the engine manufacturer's maintenance specifications.

Blue Bird recommends strictly abiding by the engine manufacturer's testing and maintenance schedules and draining, flushing, refilling procedures to maintain compliance with the engine warranty requirements. Blue Bird also recommends that you maintain accurate vehicle-specific service records of all coolant system maintenance procedures performed.

The cost of the testing is the owner's responsibility as part of the engine manufacturer's requirements for testing and maintaining the engine and coolant.

For Cummins engines using Fleetguard Fleetcool EX coolant, send coolant samples to Fleetguard for Monitor C testing, as specified in the Cummins Operator's Manual. Label sample as Conventional coolant.

For Cummins engines using Fleetguard ES Compleat OAT extended life coolant, send coolant samples to Fleetguard for Monitor C testing, as specified in the Cummins Operator's Manual. Label sample as Extended-Life coolant.

**CAUTION** *Never mix coolant types.*

Routine coolant addition (top-off) must match the installed coolant type and brand. Do not mix coolants of different colors, types, or brands in the same engine.

**CAUTION** *Always mix concentrate with premix coolant, not water.*

If concentrated coolant is added in order to raise the glycol ratio, use only the concentrate version of the same premix coolant type and brand as installed. Do not mix the concentrate with water. Instead mix the concentrate with the premix version of the same coolant.

**CAUTION** *Only add tap water in emergency situations.*

A regularly-scheduled bus inspection and maintenance program should be followed to prevent coolant losses due to damaged or worn hoses, loose clamps, etc.



If coolant is lost while the bus is in use, and roadside emergency measures are called for, replenish the coolant with the same premix type and brand if possible. If the proper coolant is not available, and water must be used, use only de-ionized water if possible. Ordinary tap water should only be used if proper coolant or de-ionized water are not available.

Whenever tap water alone has been added, the bus should be taken to a service facility and the entire cooling system should be completely drained, flushed, and refilled with premix coolant.

Blue Bird buses equipped with Cummins engines may also be equipped with an optional coolant filter. The coolant filter should be replaced every 6 months or 6,000 miles; whichever occurs first. The coolant filter element installed at the Blue Bird factory is compatible with all of the above-described coolants:

**BLUE BIRD NUMBER 00064641**

See your Blue Bird *A3 Service Manual* for complete detailed *Coolant Fill* procedures.

## **Shutters**

The optional radiator shutters assist in maintaining a constant engine temperature by limiting the air flow through the radiator. The shutter blades are powered by air or hydraulic pressure from the brake system on the vehicle. The shutters are controlled automatically by an Alarmstat which is located in the upper radiator hose and an electric solenoid in the air line controlling the shutters. The shutters require no lubrication but must be cleaned as required or at least every two years or 24,000 miles, whichever occurs first. See the shutters installation diagrams provided with vendor maintenance information for plumbing, wiring, and parts requirements.

## Transmission

### Transmission Breather

The transmission has a self-contained breather at the top left rear of the transmission main housing. The breather provides a passage for normal expansion and contraction of air and fluid within the transmission. Be careful to avoid plugging this breather with paint, undercoating, or any other material. A small amount of oil mist comes out of the breather during normal operation. If an excessive amount of oil is found in this area, the cause should be investigated.

**CAUTION** *When cleaning the transmission, do not spray steam, water, or cleaning solution directly at the breather. This may contaminate the transmission fluid.*

### Transmission Fluid Level

Transmission fluid cools, lubricates, and transmits hydraulic power. Always maintain proper fluid level. If fluid level is too low, the torque converter and clutches do not receive an adequate supply of fluid and the transmission will overheat. If the level is too high, the fluid aerates, causing the transmission to shift erratically and overheat. Fluid may be expelled through the breather or dipstick tube when the fluid level is too high. Please see your Allison Transmission Operator's Manual for information on how to check fluid levels at both cold and hot engine temperatures. Allison recommends a transmission fluid that meets DEXRON®-III specifications.

### Transmission Fluid And Filter Changes

Please see your Allison Transmission Operator's Manual for procedures to change transmission fluid and filters, and the intervals at which these should be done.



## Rear Axle

All drive axles have a vent on the top of the axle housing that allows the axle to breathe as the axle temperature changes. The vent must remain open to prevent seal failures. It is normal for the vent to ooze a small amount of lubricant.

## Hydraulic Brakes

The brakes self-adjust for lining wear. Brake fluid in the reservoir, located behind the driver's seat, must be maintained to the correct level. As the brake linings wear, fluid level in the reservoir will go down, displacing the lining loss.

**CAUTION** Use only DOT brake fluid in this reservoir.

**WARNING** Put only brake fluid in the brake fluid reservoir and only power steering fluid in the power steering system. Mixing fluids or failure to use the proper fluid, could result in loss of braking or steering.

## Parking Brake Adjustment (Hand Operated)

On All Americans with hydraulic brakes, the hand operated parking brake is adjusted by turning the knob on the parking brake lever. The knob is held in place with a set screw, and can be adjusted when the parking brake is released. When the parking brake is properly adjusted, 120–125 pounds of force—as measured 2" from the end of the lever—is required to set the brake.

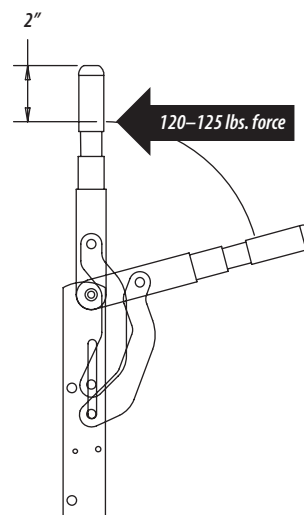

## WINDSHIELD WIPERS

### Washer Solution Reservoir

Periodically check the windshield washer solution reservoir, located behind the driver's side front access panel of the All American Rear Engine. It is located behind the front access panel on the entrance door side of the Front Engine model. Be sure there is an adequate supply of fluid at all times. The solution used is a 50/50 mixture of methanol and water.

### Wiper Assembly Replacement

To replace wiper assembly (Figure 1), loosen lock nut, remove screw, and pull wiper assembly loose from wiper arm. Replace the wiper assembly and use original screw and lock nut. Tighten lock nut securely, but do not tighten enough to compress the saddle. Blade must be free to move on the axis (machine screw) and within the saddle. Threading the lock nut until flush with the machine screw end will give a secure and serviceable installation.

### Wiper Refill Replacement

To remove wiper refills, follow the procedure outlined below.

1. Lift end clip with screwdriver as shown in Figure 2. This releases locking indentations (A in Figure 3) and allows end clip retainers (B in Figure 3) to be removed through blade claw.
2. Repeat procedure on the opposite end of the wiper.
3. New end clips (Figure 3) are provided with replacement Anco™ refills. To install, remove one clip and slide the refill through all claws until the end clip locks in position.
4. Install the second end clip, and snap-lock devices A and B into place to secure refill.

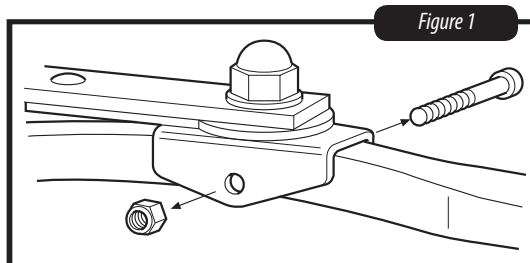

Figure 1

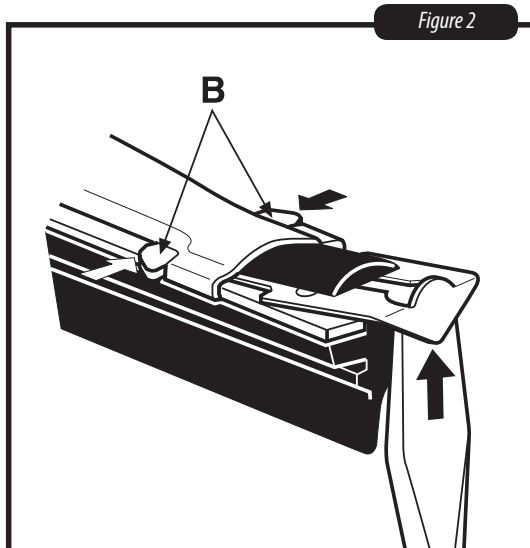

Figure 2

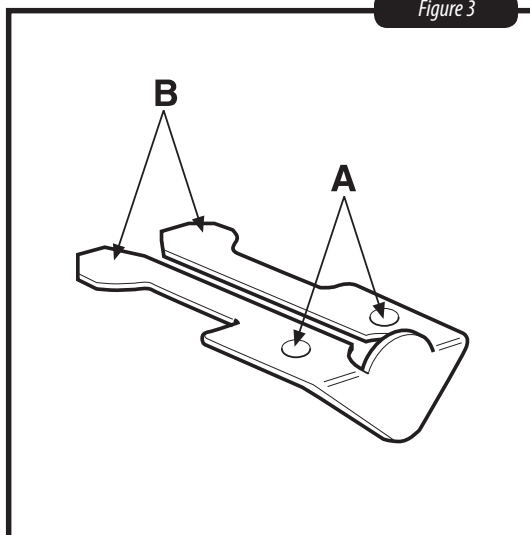

Figure 3



## CLEANING

### Exterior Cleaning

Before cleaning and waxing your bus a few basic rules should be followed:

- Start your project with the bus out of direct sunlight.
- Make sure the paint is not warm to the touch before applying any cleaning product or wax.
- Spray your bus with ample amounts of water before washing. Use the water to spray off dirt and other contaminants that will scratch the surface.
- Wash and rinse in sections so the wash soap doesn't dry before being rinsed off.
- Drying your bus after washing is necessary to prevent water spots – mineral deposits that etch the outline of a drop of water into your vehicle's paint.
- Read the manufacturer's directions on all products used prior to use.

### Wash

In order to preserve your vehicle's finish, Blue Bird requires protection of the finish by washing a minimum once every 3 months.

- Wash the vehicle in lukewarm or cold water.
- Use a lamb's-wool or paint-safe microfiber washing mitt to prevent scratching the surface.
- Do not use hot water or wash in the direct rays of the sun.
- Do not use strong soap or chemical detergents.

Only cleaners with an HMIS rating of 1,0,0,0 or less should be used to clean the buses. This HMIS rating is available on all product MSDS.

<b>Hazard Rating (NFPA/HMIS)</b> Health = 1    Reactivity = 0 Fire = 0      Special = 0		<b>Rating Scale</b> 0 = Minimum    1 = Slight 2 = Moderate    3 = Serious 4 = Severe
---	--	---

To wash units, Blue Bird Corporation recommends Bird Bath™ Bus Wash & Wax Concentrate, available from authorized Blue Bird Dealers. Bus Wash & Wax is a concentrated vehicle wash (rated triple-zero) that is recommended to be mixed at up to a 20/1 ratio for new and reconditioned buses.

**CAUTION** *Pressure washing may cause damage to finish. Pre-test pressure washer on a similar surface before applying pressure and chemicals to your vehicle. Pressure washers that re-circulate should filter the water to remove abrasive grit.*

Magnesium chloride, calcium chloride and other salts, ice melting agents, road oil and tar, tree sap, bird droppings, chemicals from industrial chimneys, and other foreign matter may damage vehicle finishes if allowed to remain on painted surfaces. Prompt washing may not completely remove all of these deposits. Additional cleaners may be needed. When using chemical cleaners developed for this purpose, be certain they are safe for use on painted surfaces.

### Wax

Wax your bus a minimum of once a year with a nonabrasive wax. This is required to remove accumulated residue and eliminate any weathered appearance. It is essential that units are not waxed in direct sunlight.

Products labeled cleaner wax or polish should not be used as they are somewhat abrasive and can actually remove some paint from the surface of the vehicle. Care should be taken when choosing a wax to make sure that it does not contain abrasive materials i.e.; calcium carbonate, pumice, plastic beads, etc.

- Before waxing, thoroughly wash and dry the bus.
- Never wash or wax a bus in direct sunlight or if the paint is hot to the touch. The sun can soften the paint and make it more susceptible to scratching.
- Use a lamb's-wool mitt for washing and soft cotton rags or microfiber towels for waxing. Do not use rags for waxing; they can trap dirt and scratch the finish. Synthetic fabrics and brushes can also scratch the finish.
- Wash and wax in small sections. This saves time and if the wax stays on too long, it can be difficult to remove.

### Bus Downtime Treatment

During periods of bus downtime, Blue Bird Corporation recommends the application of Bird Bath™ Bus Guard Protectant available from Blue Bird authorized dealers to protect exterior surfaces. Bus Guard is a triple-zero product that, when properly applied, protects against harmful UV rays and other damaging environmental conditions. For sufficient protection, see product instructions for the proper application requirement.

*Owners should refer to the limited warranty statement supplied with the vehicle regarding their responsibilities for care and maintenance of the vehicle during the warranty period.*

#### Approved Waxes

- Mequiars Gold Class Liquid Wax
- Mequiars NXT Generation® Tech Wax® 2.0 Paste or Liquid
- Black Magic Wet Shine Liquid Wax
- Turtle Wax Carnauba Car Wax T-6
- Turtle Wax 1 Step Wax & Dry T-9
- Nu Finish NFP-80



## Floor Cleaning

Regular cleaning and care will prolong the life of floor covering and improve the general appearance. Floor coverings should be swept daily and mopped weekly with a mild detergent and water. Do not use floor sweeping compounds. Be sure to remove dirt, pencils, paper, and any other debris that may cause the emergency door to seal improperly. Do not use harsh detergents or excessive amounts of water. Do not use a water hose to wash out the bus. Deterioration and damage to the wood floor could occur.

**CAUTION** *Petroleum products, such as oil and grease, quickly deteriorate the floor covering. These types of products should be removed from the surface as soon as possible. Continuous care must be exercised in the stepwell area, where foreign objects can create a safety hazard. The accumulation of dirt and foreign material in the stepwell area creates a hazard for passengers and could prevent the doors from operating properly. Ensure that screws for floor trims and aisle trims are seated tightly.*

## HEATER CARE

The front heater can be accessed from the curbside access panel outside the bus at the front, and from the inside, on the dash near the stepwell. To access the heater core and filter inside the bus, remove the interior heater access panel shown.

### Annual Maintenance

Maintenance intervals for filters and cores are minimum. In extreme dusty and dirty environments the maintenance must be performed more often to insure proper air flow. Maintenance and inspection of all the heater cores and filters and/or screens in the heater system is critical to prevent loss of efficiency, function and/or premature heater motor failure. Replace parts with OEM parts purchased from you Blue Bird Dealer.

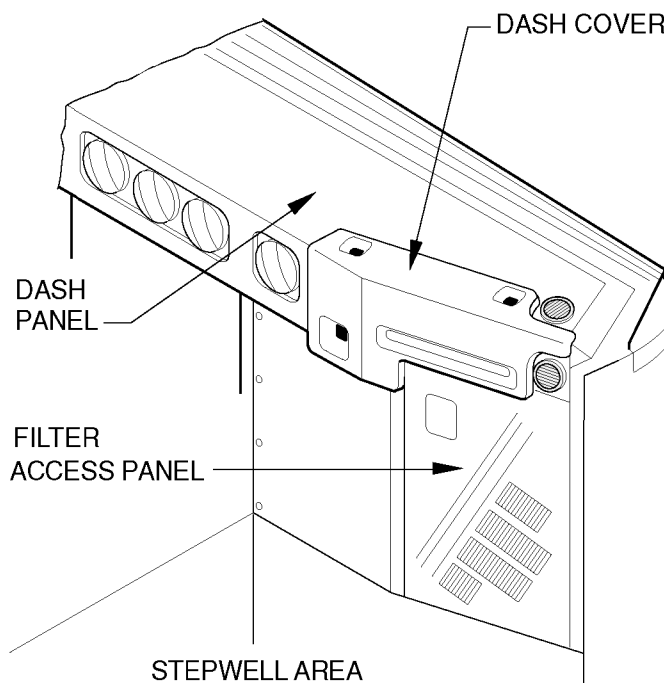

### Filter

The main heater core is protected by an air filter, which prevents dirt and dust from collecting on the heat exchange surfaces and thereby lowering heater efficiency. The driver's underseat heater has a screen. Care should be taken to keep screens and filters clean. A dirty filter restricts airflow and reduces heater output. To clean or replace the filter, remove the filter access panel. The filters and screen are washable. If a filter cannot be washed or is damaged, it **MUST** be replaced immediately. If the screen cannot be cleaned a new screen **MUST** be installed immediately. The filters must be inspected, cleaned or replaced every 12 months or 12,000 miles.

### Hoses

Check all water hoses for kinks that can prevent water flow or chafing that can cause failure. Look and feel for hardening of rubber or cracks that result from aging. Hoses should be replaced when cracks first appear. Hoses under the bus and in the engine area will deteriorate faster than those inside the bus. Exposed hoses should be checked more frequently.

### Cores

The heater will be most efficient when the core is clean. The core should be cleaned carefully with compressed dry air or vacuum and a soft bristle brush. Damaged fins should be straightened with a fin comb to prevent airflow restrictions. The forward heater core can be accessed through the right front inside access panel. Under seat heaters are accessed by removing the passenger seat cushions that are over them. Heater cores must be inspected and cleaned every 12 months or 12,000 miles.



### Motors, Switches, Blowers, and Fans

Maintenance free motors are used and do not require lubrication or cleaning over their operating life. However, excessive vibration caused by damaged blower wheels or fans can cause motor damage. Inspect wheels and fans for obstruction or damage by running each fan individually, listening and feeling for irregularities. Replace damaged wheels or fans to prevent damage to parts, fasteners, and motors.

Switches are also maintenance free; however, loose wiring connections to switches or motors can cause excessive resistance and overheating damage. Wires to switches can be checked or repaired by removing the switch mounting panel next to the driver's seat.

### Panels and Housings

Fasteners should be checked and tightened as necessary. A loose screw may allow a panel to vibrate, resulting in excessive noise, more loose screws, and/or metal fatigue.

### Cleaning Auxiliary Fans

Auxiliary fan motor bearings are lifetime-lubricated, and do not require maintenance. Clean the blade and guard occasionally, with a soft bristle brush and a vacuum cleaner or compressed air, to help maintain efficiency. As with any other fan, if the blade is damaged or unbalanced, vibration damage can occur to the motor or surrounding components. If this is the case, the blade should be replaced immediately.

**WARNING** Do not operate a fan without the fan guard properly installed.

Procedure:

1. Remove the front half of the fan guard by gently separating the plastic tabs with a screwdriver or other hard instrument. Be careful not to damage the tabs, as these connect the front half of the fan guard to the rear half.
2. To remove the fan blade, use a 3/32-inch Allen wrench in the setscrew located directly behind the fan. This should loosen the fan blade for removal.
3. The rear half of the fan guard can also be removed if necessary. After pulling away the fan, remove the two nuts and washers on either side of the center point and lift off the rear piece.

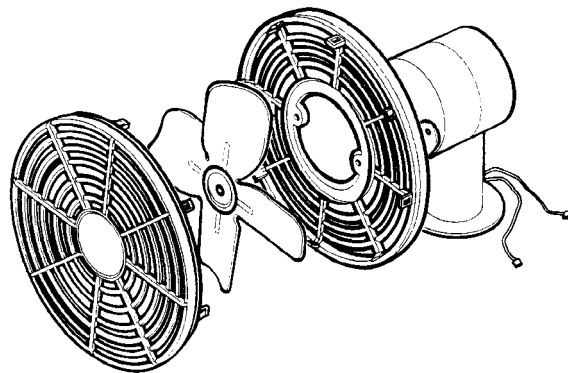

## MAINTENANCE SCHEDULE

### Maintenance Task Schedule, A3FE

Ensure that the Safety Information, warnings and instructions are read and understood before operation or maintenance procedures are performed. Use whichever interval listed (time, mileage, engine hours) occurs first. Engines operated in severe operating conditions may require more frequent maintenance. See engine manufacturer's specifications for more information.

#### As Specified by Engine Manufacturer

##### Cooling System

Replace Coolant

See your Engine Operator's Manual. Use only premixed coolant(s) approved by the engine manufacturer. Never mix different types or brands of coolant.

##### Engine

Replace Oil & Filter

See Engine operators manual for oil and filter specifications and maintenance interval.

Adjust Valves

See Engine manufacturer's Service Manual for interval.

#### As Specified by Transmission Manufacturer

##### Transmission

Adjust Transmission Shift Cable

See Transmission Chapter.

#### First 100 Miles Then Every 12,000 Miles

##### Tires & Wheels

Inspect & Tighten Lug Nuts

Torque to 450-500 ft lb with calibrated torque wrench. Do not over-tighten. Do not lubricate nuts or studs. Operating conditions may require more frequent checks.

#### First 1000 Miles Then Every 3 Months or 6000 Miles

##### Frame

Inspect & Tighten Body Tie Downs Body Tie Down Clamps

Inspect for missing, damaged rubber pads. Tighten clamps to 37-41 ft lb.

Inspect & Tighten Body Tie Downs Rear Isolator Mounts

Inspect rubber discs for cracking or damage. Inspect spring & fastener for damage. Tighten bracket to 70-80 ft lb. Tighten Isolator to 54-58 ft lb.

**First 1000 Miles Then Every 6 Months or 6000 Miles**
**Axle & Suspension, Front**

Lubricate Parabolic Spring Suspension Spring Pins	NLGI #2 Grease.
--	-----------------

**Axle & Suspension, Rear**

Inspect Comfort Air Suspension Ride Height	Shock length, eye-to-eye: 22.68" +/- 0.25"
---	--

**First 1000 Miles Then Every 6 Months or 12,000 Miles**
**Axle & Suspension, Rear**

Inspect & Tighten Comfort Air Suspension U-Bolts	Tighten 7/8" U-Bolts to 400–450 ft lb. Tighten 3/4" U-Bolts to 260–320 ft lb.
---	--

**First 1000 Miles Then Every 12 Months or 12,000 Miles**
**Heaters & Defrosters**

Inspect Front Heater Hoses & Clamps	Inspect for evidence of leaks or deterioration. Replace with proper parts.
-------------------------------------	---

**First 5000 Miles Then Every 12 Months or 24,000 Miles**
**Transmission**

Replace Transmission Sump Filter

**First 5000 Miles Then Every 24 Months or 24,000 Miles**
**Transmission**

Replace Transmission Main Fluid Filter

**First 11,000 Miles Then Every 3 Months or 5000 Miles or 250 Engine Hours**
**Engine**

Inspect All Belts	Inspect condition and tension of belts.
-------------------	---

**First 11,000 Miles Then Every 6 Months or 5000 Miles**
**Cooling System**

Inspect Charge Air Cooler	Inspect for clogging debris.
---------------------------	------------------------------

**First Month Then Every 3 Months or 3000 Miles**
**Cooling System**

Inspect & Tighten Hose Clamps	Tighten radiator hose clamps to 90 in lb. Tighten heater hose clamps to 45 in lb.
-------------------------------	--

**Every Day**
**Doors**

Test Wheelchair Lift	Follow the manufacturers recommendations.
----------------------	---

**Emergency Equipment**

Inspect Fire Extinguisher Charge	Ensure that Extinguisher Charge is not expired.
----------------------------------	---

Inspect Fire Extinguisher Mounting Bracket	Ensure that Extinguisher bracket is secure and operates correctly.
--	--

Inspect First Aid Kit Contents	Ensure that kit supplies are fully replenished, clean, and not expired.
--------------------------------	---

Inspect First Aid Kit Mounting Bracket	Ensure that mounting bracket is secure and operates correctly.
--	--

**Emergency Exits**

Inspect All Emergency Exits	Test all emergency exits for proper operation, including warning buzzer.
-----------------------------	--

**Warning Devices & Signs**

Test Stop Arms & Crossing Arms	
--------------------------------	--

**Windows**

Inspect All Mirrors	Clean, adjust mirrors.
---------------------	------------------------

Inspect All Windows	Clean windshield, door glass, driver's window, rear vision windows, rear door windows.
---------------------	--

**Brakes**

Inspect Air Brakes Air Lines & Fittings	Inspect for leaks or physical damage.
---	---------------------------------------

Drain Air Brakes Air Tanks	Drain daily in cold weather; weekly in warm weather.
----------------------------	--

Inspect Air Brakes Brake Chambers	See Air Brakes Chapter for inspection criteria.
-----------------------------------	---

Inspect Air Brakes Brake Shoes	Wear depends upon application environment. See Meritor Cam Brakes Appendix in Air Brakes Chapter of Service Manual for guidelines.
--------------------------------	--



### Cooling System

Inspect Coolant Level	Adjust to proper level with premixed coolant of same type as installed. Never mix coolants of different colors, types, or brands. See engine Operator's Manual for details. See decal on vehicle showing original equipment.
Inspect Entire Cooling System	Visually inspect for any signs of leakage.

### Electrical

Inspect All Lights	Check all running, stop, marker, hazard, and warning lights for proper operation.
--------------------	---

### Engine

Inspect Oil Level	See engine operators manual for oil specifications.
-------------------	---

### Fuel System

Inspect Fuel Cap

Inspect Water Separator Petcock Drain	Check for water contamination.
---------------------------------------	--------------------------------

### Intake System

Inspect Intake Tract Duct & Elbow	Visually inspect for proper fit and sealing, cuts, abrasions, signs of dirt contamination.
Inspect Intake Tract Restriction Indicator	Replace filter element if indicator is red.

### Steering

Inspect Power Steering Fluid Level	Replenish to full mark. Dexron III or approved equal.
------------------------------------	---

### Tires & Wheels

Inspect All Tires & Wheels	Check air pressure. Visually inspect tires, tread wear, lug nuts, including spare.
----------------------------	--

### Transmission

Inspect Transmission Fluid Level	Check production order for proper type of fluid to be added.
----------------------------------	--

### Every Week

#### Seats

Inspect & Tighten Passenger Seats Cushion Screws	Inspect for loose cushions clips.
Inspect Passenger Seats Seat Belts	Lubricate buckles, clean webbing as required. Replace any damaged webbing straps.
Inspect Passenger Seats Upholstery	Inspect for cuts, tears, wear and soiled areas.

#### Brakes

Inspect Hydraulic Brakes Pads	Replace if worn to within 1/8" lining remaining.
-------------------------------	--

**Every 60,000 Miles**
**Fuel System**

Replace Fuel Filter

**Every Month or 3000 Miles**
**Doors**

Clean & Lubricate All Doors Rubber Seals	Lubricate with Silicon Spray or protectant.
Adjust Jack Knife Door Air Pressure	See Body Construction / Doors / Jack Knife Door
Adjust Jack Knife Door Control Rod	Adjust for proper open/closed position.
Adjust Jack Knife Door Control Rod Bracket	Adjust to prevent pivot pin binding.
Lubricate Jack Knife Door Hinge Pins	LPS 1
Adjust Jack Knife Door Roller Bracket	Adjust for proper open/closed position.
Adjust Jack Knife Door Switch	See Body Construction / Doors / Jack Knife Door
Adjust Outward Opening Door Control Rod	
Adjust Outward Opening Door Control Rod Bracket	Adjust for full and secure closure without binding.
Adjust & Lubricate Outward Opening Door Linkage	Adjust linkage for firm closure, and to ensure rear panel closes first.
Lubricate Outward Opening Door Pivots	Lubricate pivot pins with LPS #1.
Adjust Outward Opening Door Roller Bracket	Adjust for full and secure closure without binding.
Lubricate Power Jack Knife Door Air Pressure & Switch	LPS #1
Lubricate Power Jack Knife Door Hinge	LPS #1
Lubricate Wheelchair Lift Lube Points	See model-specific literature provided with lift.

**Emergency Exits**

Lubricate All Emergency Exits Hinges	LPS #1
Lubricate Rear Emergency Door Hinges	Lubricate at hinge grease fittings.
Lubricate Rear Emergency Door Hold-Open	Apply ASTM D4950 GC-LB Grade 2
Lubricate Roof Hatch Seal and Latch	Use silicone lubricant to prevent sticking of rubber seal. Spray silicone lubricant into latch mechanism.



### Floor

Inspect Floor Drains	Check drain hole in each body section under window for debris or obstruction.
----------------------	---

### Seats

Lubricate Driver's Seat	Lubricate per manufacturers recommendation.
Inspect & Tighten Passenger Seats Mountings	Use standard torque for bolt size, thread type and grade.

### Warning Devices & Signs

Lubricate Stop Arm, Electric 4-Point Pivot	Lubricate four hinge pivot points with Try-Flow lubricant
Inspect & Tighten Stop Arm, Electric Fasteners	Check interior and exterior fasteners for loosening.

### Windows

Lubricate Passenger Windows Latches & Slides	Use silicone lubricant.
--	-------------------------

### Brakes

Inspect Hydraulic Brakes Fluid	DOT-3 brake fluid.
--------------------------------	--------------------

### Doors

Lubricate All Doors Vandal Locks	Apply spray lubricant into key locks. Use LPS #1 for sliding bolt locks.
----------------------------------	--

### Electrical

Inspect Battery Electrolyte Level	Replenish with distilled water.
-----------------------------------	---------------------------------

## Every Month or 5000 Miles

### Warning Devices & Signs

Inspect Stop Arm, Air Pressure	Adjust for full deployment and retraction.
--------------------------------	--

## Every Month or 12,000 Miles

### Axle & Suspension, Rear

Inspect Rear Axle Lubricant Level	If low, refill to bottom of filler opening. Use same lubricant type as already installed.
-----------------------------------	---

## Every 3 Months

### Exterior Structure

Wash Body	Wash the vehicle in lukewarm or cold water. Do not use hot water or wash in the direct sunlight. Only cleaners with an HMIS rating of 1,0,0,0 or less should be used to clean the buses. See Exterior Cleaning section of Driver's Handbook for further information.
-----------	--

**Every 3 Months or 3000 Miles**
**Cooling System**

Inspect Radiator Fins

Clean debris from fins.

Inspect Water Pump Belt

Inspect condition and tension of belt.

**Every 3 Months or 5000 Miles**
**Brakes**

Lubricate Air Brakes S-Cam

See Meritor Cam Brakes Appendix in Air Brakes Chapter of Service Manual for guidelines.

Lubricate Hydraulic Brakes Calipers

Lube per Meritor specs.

**Driveline**

Lubricate Driveshafts Slip Joint

Grease meeting NLGI Grade #2 grease specifications.

Lubricate Driveshafts U-Joint Bolts

Grease meeting NLGI Grade #2 grease specifications.

Inspect &amp; Tighten Driveshafts U-Joint Bolts

Tighten to 45–50 ft lb.

**Electrical**

Inspect Alternator Connections

Inspect for loose wires, damaged terminals, damaged insulators.

Inspect Battery Connections

Check for solid connection, tight fasteners and absence of corrosion.

**Fuel System**

Inspect Fuel Lines

Inspect for leaks or signs of abrasion.

Inspect Fuel Tank Vent

Inspect for obstruction.

**Intake System**

Inspect Air Cleaner Filter Element

Inspect for proper seating, secure lid. Replace if soiled, wet, or damaged.

Inspect Intake Tract All Fasteners

Inspect for signs of contaminate infiltration, loose clamps, wear spots, holes in piping.

Inspect Intake Tract Charged Air Tubing

Inspect for signs of contaminate infiltration, loose clamps, wear spots, holes in piping.

Inspect &amp; Tighten Intake Tract Hose Clamps

Tighten to 10 in lb.

Inspect &amp; Tighten Intake Tract Spring Loaded Clamps

Tighten to near full spring compression.

Inspect Intake Tract Support Bracket

Visual inspection. Repair damaged parts immediately.

Inspect &amp; Tighten Intake Tract T-Bolt Clamps

Tighten to 50 in lb.



Inspect & Tighten Intake Tract Worm Gear Clamps	Tighten to 38–42 in lb.
---	-------------------------

---

### Steering

Lubricate Axle Steering Linkage Drag Link	NLGI #2 EP multipurpose grease rated GC-LB or equivalent.
---	---

Lubricate Axle Steering Linkage King Pins	NLGI #2 EP multipurpose grease rated GC-LB or equivalent.
---	---

Lubricate Axle Steering Linkage Tie Rod Ends	NLGI #2 EP multipurpose grease rated GC-LB or equivalent.
--	---

Lubricate Intermediate Steering Shaft Slip Joint	Lubricate splines with multipurpose grease.
--	---

### Every 3 Months or 24,000 Miles

#### Brakes

Inspect Air Brakes Air Dryer	See Bendix appendix for specific model in Air Brakes Chapter of Service Manual.
------------------------------	---

Inspect Hydraulic Brakes Booster & Master Cylinder	Inspect for signs of leakage or physical damage.
--	--

### Every 6 Months or 5000 Miles

#### Warning Devices & Signs

Lubricate Destination Sign Hinges	
-----------------------------------	--

Lubricate Destination Sign Roller Gears	Lightweight grease such as White Lube.
---	--

**Every 6 Months or 6000 Miles**
**Axle & Suspension, Rear**

Inspect & Tighten Comfort Air Suspension Shock Absorbers	Inspect for signs of leakage, wear, or damage. Tighten shock mounts to 150–180 ft lb.
--	---

Inspect Comfort Air Suspension Whole Assmeby	Visually inspect for damage.
--	------------------------------

**Brakes**

Clean Air Brakes Check Valves

Clean & Lubricate Air Brakes Treadle Valve	See Bendix Treadle Valve Appendix in Air Brakes Chapter of Service Manual.
--	--

Clean Air Compressor Governor

Inspect Hydraulic Brakes Calipers	Inspect for signs of leakage or physical damage.
-----------------------------------	--

**Cooling System**

Replace Coolant Filter

Lubricate Shutters Pivots	Use Never Seize spray lubricant.
---------------------------	----------------------------------

**Electrical**

Inspect Battery Posts	Clean and apply anti corrosion agent.
-----------------------	---------------------------------------

**Exhaust System**

Inspect Exhaust Pipe Joints	Inspect for loose clamps, leaks, damage.
-----------------------------	--

**Fuel System**

Replace Fuel Filter Filter Element

Clean Fuel Filter Inlet Screen	Clean. Replace if damaged.
--------------------------------	----------------------------

**Steering**

Lubricate Steering Gear Pitman Arm Pivot	NLGI #2 EP multipurpose grease rated GC-LB or equivalent. Use hand-operated grease gun.
--	---



### Every 6 Months or 12,000 Miles

#### Axle & Suspension, Rear

Inspect & Tighten Comfort Air Suspension Air Spring Anchor Bolts	Tighten to 20–30 ft lb.
Inspect & Torque Comfort Air Suspension Air Spring Fasteners	Torque to 30–35 ft lb.
Inspect & Tighten Comfort Air Suspension Leveling Valve Mount Bolt	Tighten to 60–85 in lb.
Inspect & Tighten Comfort Air Suspension Lever Linkage Locknut	Tighten to 100–150 in lb.
Inspect & Tighten Comfort Air Suspension Lower Shock Mount	Tighten to 260–320 ft lb.
Inspect & Tighten Comfort Air Suspension Quick Align Bolts	Tighten to 525–575 ft lb.

#### Brakes

Lubricate Air Brakes Cam Shaft Housing	NLGI #2 EP multipurpose grease rated GC-LB or equivalent. Use hand-operated grease gun.
Lubricate Air Brakes Haldex Slack Adjusters	See Haldex lubricant specs in Air Brakes chapter of Service Manual.
Lubricate Air Brakes Meritor Slack Adjusters	See Meritor lubricant specs in Air Brakes chapter of Service Manual.

### Every 12 Months

#### Exterior Structure

Wax Body	Use of a nonabrasive wax is recommended to remove accumulated residue and eliminate any "weathered appearance". It is essential that units are not waxed in direct sunlight. See Exterior Cleaning section of Driver's Handbook for further information and approved waxes.
----------	---

#### Intake System

Test Intake Tract Restriction Indicator	Test indicator with vacuum gauge and pump.
---	--

**Every 12 Months or 12,000 Miles**
**Heaters & Defrosters**

Tighten Front Heater Fasteners	All fasteners holding such heaters in place in unit. For details on fasteners check installation prints.
Inspect, clean and replace Front Heater Filter & Screen	Wash filter and screen. If filter cannot be washed or is damaged, the filter <b>MUST</b> be replaced immediately. If a screen cannot be cleaned, a new screen must be installed immediately.
Inspect and clean Front Heater Heater Cores	Clean carefully with compressed dry air or vacuum and a soft bristle brush. Damaged fins should be straightened with a fin comb.
Inspect and clean Heater Cores	The core should be cleaned carefully with compressed dry air or vacuum and a soft bristle brush. Damaged fins should be straightened with a fin comb to prevent airflow restrictions.
Bleed Heater System	Bleed air from heater circulation system. This procedure is done to keep system operating correctly.
Inspect, clean or replace Heater System Filter	The filter and screen are washable. If a filter cannot be washed or is damaged, the filter <b>MUST</b> be replaced immediately. If the screen cannot be cleaned, a new screen must be installed immediately. Filter may need to be cleaned or replaced more frequently in extreme dusty and dirty environments.
Clean Underseat Heaters Filter Elements	Clean dust from cores.

**Axle & Suspension, Front**

Inspect Parabolic Spring Suspension Entire Assembly	Visually inspect for damage or misalignment.
Inspect & Tighten Parabolic Spring Suspension Hangar Bracket Bolts	Tighten to 75–85 ft lb.
Inspect Parabolic Spring Suspension Shock Absorbers	Visually inspect for leakage or damage.



### Axle & Suspension, Rear

Inspect Comfort Air Suspension Ride Height	Shock length, eye-to-eye: 22.68" +- .25"
Inspect & Tighten Comfort Air Suspension Shock Absorbers	Inspect for leakage or damage. Torque upper mount bolts to 50-70 ft lb. Torque lower mount bolts to 160-180 ft lb.
Inspect & Tighten Comfort Air Suspension Torque Arm Bolts	Torque to 150–205 ft lb.
Inspect & Tighten Comfort Air Suspension U-Bolts	Torque 7/8" bolts to 400–450 ft lb. Torque 3/4" bolts to 260–320 ft lb.

### Cooling System

Test Entire Cooling System	Pressure Test Cooling system.
Clean Radiator Fins	Clean as required.

### Engine

Test Engine Starting Aid Block Heater	
---------------------------------------	--

### Steering

Inspect Hydraulic Pump Body & Seals	Inspect for leaks.
Inspect Steering Gear Body & Seals	Inspect for leaks.

## Every 12 Months or 24,000 Miles

### Brakes

Clean Air Brakes Pop Off Valves	
---------------------------------	--

### Steering

Replace Hydraulic Reservoir Filter Element	Replace element and fluid. Replace more frequently in severe operating conditions. Dexron III or approved equal.
--	--

### Transmission

Replace Transmission Fluid	Use TransSynd fluid.
Inspect Transmission Shift Cable	
Inspect Transmission Vent	Clear vent of debris or obstruction.

## Every 12 Months or 50,000 Miles

### Axle & Suspension, Rear

Replace Rear Axle Petroleum Based Lubricant	Hypoid Gear Oil. Viscosity depends upon operating climate. See Viscosity/Temperature chart.
---	---

**Every 12 Months or 90,000 Miles****Axle & Suspension, Rear**

Replace Rear Axle Synthetic Lubricant

Viscosity depends upon operating climate. See Viscosity/Temperature chart.

**Every 24 Months or 24,000 Miles****Brakes**

Clean Air Brakes Parking Brake Valve

See Bendix Appendixes in Air Brakes Chapter.

Clean Air Brakes Quick Release Valves

See Bendix Appendixes in Air Brakes Chapter.

Clean Air Brakes Relay Valves

See Bendix Appendixes in Air Brakes Chapter.

Clean Air Brakes Spring Brake Valve

See Bendix Appendixes in Air Brakes Chapter.

**Every 24 Months or 225,000 Miles****Exhaust System**

Replace DEF Supply Module Filter

Replace DEF Tank Head Unit Filter



## Maintenance Task Schedule, A3RE

Ensure that the Safety information, warnings and instructions are read and understood before operation or maintenance procedures are performed. Use whichever interval listed (time, mileage, engine hours) occurs first. Engines operated in severe operating conditions may require more frequent maintenance. See engine manufacturer's specifications for more information.

### As Specified by Engine Manufacturer

#### Cooling System

Replace Coolant	See your Engine Operator's Manual. Use only premixed coolant(s) approved by the engine manufacturer. Never mix different types or brands of coolant.
-----------------	--

#### Engine

Replace Oil & Filter	See Engine operators manual for oil and filter specifications and maintenance interval.
Adjust Valves	See Engine manufacturer's Service Manual for interval.

### As Specified by Transmission Manufacturer

#### Transmission

Adjust Transmission Shift Cable	See Transmission Chapter.
---------------------------------	---------------------------

### First Month Then Every 3 Months or 3000 Miles

#### Cooling System

Inspect & Tighten Hose Clamps	Tighten radiator hose clamps to 90 in lb. Tighten heater hose clamps to 45 in lb.
-------------------------------	---

### First 100 Miles Then Every 12,000 Miles

#### Tires & Wheels

Inspect & Tighten Lug Nuts	Torque to 450-500 ft lb with calibrated torque wrench. Do not over-tighten. Do not lubricate nuts or studs. Operating conditions may require more frequent checks.
----------------------------	--

### First 1000 Miles Then Every 3 Months or 6000 Miles

#### Frame

Inspect & Tighten Body Tie Downs Body Tie Down Clamps	Inspect for missing, damaged rubber pads. Tighten clamps to 37-41 ft lb.
Inspect & Tighten Body Tie Downs Rear Isolator Mounts	Inspect rubber discs for cracking or damage. Inspect spring & fastener for damage. Tighten bracket to 70-80 ft lb. Tighten Isolator to 54-58 ft lb.

**First 1000 Miles Then Every 6 Months or 6000 Miles**
**Axle & Suspension, Rear**

Inspect Comfort Air Suspension Ride Height

Shock length, eye-to-eye: 22.68" +/- 0.25"

**First 1000 Miles Then Every 6 Months or 12,000 Miles**
**Axle & Suspension, Rear**

Inspect &amp; Tighten Comfort Air Suspension U-Bolts

Tighten 7/8" U-Bolts to 400–450 ft lb. Tighten 3/4" U-Bolts to 260–320 ft lb.

**First 1000 Miles Then Every 12 Months or 12,000 Miles**
**Heaters & Defrosters**

Inspect Front Heater Hoses &amp; Clamps

Inspect for evidence of leaks or deterioration. Replace with proper parts.

**First 5000 Miles Then Every 12 Months or 24,000 Miles**
**Transmission**

Replace Transmission Sump Filter

**First 5000 Miles Then Every 24 Months or 24,000 Miles**
**Transmission**

Replace Transmission Main Fluid Filter

**First 11,000 Miles Then Every 3 Months or 5000 Miles or 250 Engine Hours**
**Engine**

Inspect All Belts

Inspect condition and tension of belts.

**First 11,000 Miles Then Every 6 Months or 5000 Miles**
**Cooling System**

Inspect Charge Air Cooler

Inspect for clogging debris.

**First Month Then Every 3 Months or 3000 Miles**
**Cooling System**

Inspect &amp; Tighten Hose Clamps

Tighten radiator hose clamps to 90 in lb. Tighten heater hose clamps to 45 in lb.



## Every Day

### Doors

Test Wheelchair Lift	Follow the manufacturers recommendations.
----------------------	---

### Emergency Equipment

Inspect Fire Extinguisher Charge	Ensure that Extinguisher Charge is not expired.
----------------------------------	---

Inspect Fire Extinguisher Mounting Bracket	Ensure that Extinguisher bracket is secure and operates correctly.
--	--

Inspect First Aid Kit Contents	Ensure that kit supplies are fully replenished, clean, and not expired.
--------------------------------	---

Inspect First Aid Kit Mounting Bracket	Ensure that mounting bracket is secure and operates correctly.
--	--

### Emergency Exits

Inspect All Emergency Exits	Test all emergency exits for proper operation, including warning buzzer.
-----------------------------	--

### Warning Devices & Signs

Test Stop Arms & Crossing Arms	
--------------------------------	--

### Windows

Inspect All Mirrors	Clean, adjust mirrors.
---------------------	------------------------

Inspect All Windows	Clean windshield, door glass, driver's window, rear vision windows, rear door windows.
---------------------	--

### Brakes

Inspect Air Brakes Air Lines & Fittings	Inspect for leaks or physical damage.
---	---------------------------------------

Drain Air Brakes Air Tanks	Drain daily in cold weather; weekly in warm weather.
----------------------------	--

Inspect Air Brakes Brake Chambers	See Air Brakes Chapter for inspection criteria.
-----------------------------------	---

Inspect Air Brakes Brake Shoes	Wear depends upon application environment. See Meritor Cam Brakes Appendix in Air Brakes Chapter of Service Manual for guidelines.
--------------------------------	--

---

**Cooling System**

---

Inspect Coolant Level

Adjust to proper level with premixed coolant of same type as installed. Never mix coolants of different colors, types, or brands. See engine Operator's Manual for details. See decal on vehicle showing original equipment.

Inspect Entire Cooling System

Visually inspect for any signs of leakage.

---

**Electrical**

---

Inspect All Lights

Check all running, stop, marker, hazard, and warning lights for proper operation.

---

**Engine**

---

Inspect Oil Level

See engine operators manual for oil specifications.

---

**Fuel System**

---

Inspect Fuel Cap

Inspect Water Separator Petcock Drain

Check for water contamination.

---

**Intake System**

---

Inspect Intake Tract Duct &amp; Elbow

Visually inspect for proper fit and sealing, cuts, abrasions, signs of dirt contamination.

Inspect Intake Tract Restriction Indicator

Replace filter element if indicator is red.

---

**Steering**

---

Inspect Power Steering Fluid Level

Replenish to full mark. Dexron III or approved equal.

---

**Tires & Wheels**

---

Inspect All Tires &amp; Wheels

Check air pressure. Visually inspect tires, tread wear, lug nuts, including spare.

---

**Transmission**

---

Inspect Transmission Fluid Level

Check production order for proper type of fluid to be added.

---

**Every Week**

---

**Seats**

---

 Inspect & Tighten Passenger Seats Cushion  
Screws

Inspect for loose cushions clips.

Inspect Passenger Seats Seat Belts

Lubricate buckles, clean webbing as required. Replace any damaged webbing straps.

Inspect Passenger Seats Upholstery

Inspect for cuts, tears, wear and soiled areas.



### Every 60,000 Miles

#### Fuel System

Replace Fuel Filter

### Every Month or 3000 Miles

#### Doors

Adjust Jack Knife Door Air Pressure	See Body Construction / Doors / Jack Knife Door
Adjust Jack Knife Door Control Rod	Adjust for proper open/closed position.
Adjust Jack Knife Door Control Rod Bracket	Adjust to prevent pivot pin binding.
Lubricate Jack Knife Door Hinge Pins	LPS 1
Adjust Jack Knife Door Roller Bracket	Adjust for proper open/closed position.
Adjust Jack Knife Door Switch	See Body Construction / Doors / Jack Knife Door
Adjust Outward Opening Door Control Rod	
Adjust Outward Opening Door Control Rod Bracket	Adjust for full and secure closure without binding.
Adjust & Lubricate Outward Opening Door Linkage	Adjust linkage for firm closure, and to ensure rear panel closes first.
Lubricate Outward Opening Door Pivots	Lubricate pivot pins with LPS #1.
Adjust Outward Opening Door Roller Bracket	Adjust for full and secure closure without binding.
Lubricate Power Jack Knife Door Air Pressure & Switch	LPS #1
Lubricate Power Jack Knife Door Hinge	LPS #1
Lubricate Wheelchair Lift Lube Points	See model-specific literature provided with lift.
<b>Emergency Exits</b>	
Lubricate All Emergency Exits Hinges	LPS #1
Lubricate Rear Emergency Door Hold-Open	Apply ASTM D4950 GC-LB Grade 2
Lubricate Roof Hatch Seal and Latch	Use silicone lubricant to prevent sticking of rubber seal. Spray silicone lubricant into latch mechanism.

---

**Floor**

Inspect Floor Drains

Check drain hole in each body section under window for debris or obstruction.

---

**Seats**

Lubricate Driver's Seat

Lubricate per manufacturers recommendation.

Inspect &amp; Tighten Passenger Seats Mountings

Use standard torque for bolt size, thread type and grade.

---

**Warning Devices & Signs**

Lubricate Stop Arm, Electric 4-Point Pivot

Lubricate four hinge pivot points with Try-Flow lubricant

Inspect &amp; Tighten Stop Arm, Electric Fasteners

Check interior and exterior fasteners for loosening.

---

**Windows**

Lubricate Passenger Windows Latches &amp; Slides

Use silicone lubricant.

---

**Doors**

Lubricate All Doors Vandal Locks

Apply spray lubricant into key locks. Use LPS #1 for sliding bolt locks.

---

**Electrical**

Inspect Battery Electrolyte Level

Replenish with distilled water.

---

**Every Month or 5000 Miles**

---

**Warning Devices & Signs**

Inspect Stop Arm, Air Pressure

Adjust for full deployment and retraction.

---

**Every Month or 12,000 Miles**

---

**Axle & Suspension, Rear**

Inspect Rear Axle Lubricant Level

If low, refill to bottom of filler opening. Use same lubricant type as already installed.

---

**Every 3 Months**

---

**Exterior Structure**

Wash Body

Wash the vehicle in lukewarm or cold water. Do not use hot water or wash in the direct sunlight. Only cleaners with an HMIS rating of 1,0,0,0 or less should be used to clean the buses. See Exterior Cleaning section of Driver's Handbook for further information.



### Every 3 Months or 3000 Miles

#### Cooling System

Inspect Radiator Fins	Clean debris from fins.
Inspect Water Pump Belt	Inspect condition and tension of belt.

### Every 3 Months or 5000 Miles

#### Brakes

Lubricate Air Brakes S-Cam	See Meritor Cam Brakes Appendix in Air Brakes Chapter of Service Manual for guidelines.
----------------------------	---

#### Driveline

Lubricate Driveshafts Slip Joint	Grease meeting NLGI Grade #2 grease specifications.
Lubricate Driveshafts U-Joint Bolts	Grease meeting NLGI Grade #2 grease specifications.
Inspect & Tighten Driveshafts U-Joint Bolts	Tighten to 45–50 ft lb.

#### Electrical

Inspect Alternator Connections	Inspect for loose wires, damaged terminals, damaged insulators.
Inspect Battery Connections	Check for solid connection, tight fasteners and absence of corrosion.

#### Fuel System

Inspect Fuel Lines	Inspect for leaks or signs of abrasion.
Inspect Fuel Tank Vent	Inspect for obstruction.

#### Intake System

Inspect Air Cleaner Filter Element	Inspect for proper seating, secure lid. Replace if soiled, wet, or damaged.
Inspect Intake Tract All Fasteners	Inspect for signs of contaminate infiltration, loose clamps, wear spots, holes in piping.
Inspect Intake Tract Charged Air Tubing	Inspect for signs of contaminate infiltration, loose clamps, wear spots, holes in piping.
Inspect & Tighten Intake Tract Hose Clamps	Tighten to 10 in lb.
Inspect & Tighten Intake Tract Spring Loaded Clamps	Tighten to near full spring compression.
Inspect Intake Tract Support Bracket	Visual inspection. Repair damaged parts immediately.
Inspect & Tighten Intake Tract T-Bolt Clamps	Tighten to 50 in lb.

Inspect & Tighten Intake Tract Worm Gear Clamps	Tighten to 38–42 in lb.
---	-------------------------

---

**Steering**

Lubricate Axle Steering Linkage Drag Link	NLGI #2 EP multipurpose grease rated GC-LB or equivalent.
---	---

Lubricate Axle Steering Linkage King Pins	NLGI #2 EP multipurpose grease rated GC-LB or equivalent.
---	---

Lubricate Axle Steering Linkage Tie Rod Ends	NLGI #2 EP multipurpose grease rated GC-LB or equivalent.
--	---

Lubricate Intermediate Steering Shaft Slip Joint	Lubricate splines with multipurpose grease.
--	---

---

**Every 3 Months or 24,000 Miles**
**Brakes**

Inspect Air Brakes Air Dryer	See Bendix appendix for specific model in Air Brakes Chapter of Service Manual.
------------------------------	---

---

**Every 6 Months or 5000 Miles**
**Warning Devices & Signs**

Lubricate Destination Sign Hinges

Lubricate Destination Sign Roller Gears	Lightweight grease such as White Lube.
---	--

**Every 6 Months or 6000 Miles**
**Axle & Suspension, Rear**

Inspect & Tighten Comfort Air Suspension Shock Absorbers	Inspect for signs of leakage, wear, or damage. Tighten shock mounts to 150–180 ft lb.
--	---

Inspect Comfort Air Suspension Whole Assmely	Visually inspect for damage.
--	------------------------------

**Brakes**

Clean Air Brakes Check Valves

Clean & Lubricate Air Brakes Treadle Valve	See Bendix Treadle Valve Appendix in Air Brakes Chapter of Service Manual.
--	--

Clean Air Compressor Governor

**Cooling System**

Replace Coolant Filter

Lubricate Shutters Pivots	Use Never Seize spray lubricant.
---------------------------	----------------------------------

**Electrical**

Inspect Battery Posts	Clean and apply anti corrosion agent.
-----------------------	---------------------------------------

**Exhaust System**

Inspect Exhaust Pipe Joints	Inspect for loose clamps, leaks, damage.
-----------------------------	--

**Fuel System**

Replace Fuel Filter Filter Element

Clean Fuel Filter Inlet Screen	Clean. Replace if damaged.
--------------------------------	----------------------------

**Steering**

Lubricate Steering Gear Pitman Arm Pivot	NLGI #2 EP multipurpose grease rated GC-LB or equivalent. Use hand-operated grease gun.
--	---

**Every 6 Months or 12,000 Miles**
**Axle & Suspension, Rear**

Inspect & Tighten Comfort Air Suspension Air Spring Anchor Bolts	Tighten to 20–30 ft lb.
---	-------------------------

Inspect & Torque Comfort Air Suspension Air Spring Fasteners	Torque to 30–35 ft lb.
---	------------------------

Inspect & Tighten Comfort Air Suspension Leveling Valve Mount Bolt	Tighten to 60–85 in lb.
---	-------------------------

Inspect & Tighten Comfort Air Suspension Lever Linkage Locknut	Tighten to 100–150 in lb.
---	---------------------------

Inspect & Tighten Comfort Air Suspension Lower Shock Mount	Tighten to 260–320 ft lb.
---	---------------------------

Inspect & Tighten Comfort Air Suspension Quick Align Bolts	Tighten to 525–575 ft lb.
---	---------------------------

**Brakes**

Lubricate Air Brakes Cam Shaft Housing	NLGI #2 EP multipurpose grease rated GC-LB or equivalent. Use hand-operated grease gun.
--	---

Lubricate Air Brakes Haldex Slack Adjusters	See Haldex lubricant specs in Air Brakes chapter of Service Manual.
---	---

Lubricate Air Brakes Meritor Slack Adjusters	See Meritor lubricant specs in Air Brakes chapter of Service Manual.
--	--

**Every 12 Months**
**Exterior Structure**

Wax Body	Use of a nonabrasive wax is recommended to remove accumulated residue and eliminate any "weathered appearance". It is essential that units are not waxed in direct sunlight. See Exterior Cleaning section of Driver's Handbook for further information and approved waxes.
----------	---

**Intake System**

Test Intake Tract Restriction Indicator	Test indicator with vacuum gauge and pump.
---	--

**Every 12 Months or 12,000 Miles**
**Heaters & Defrosters**

Tighten Front Heater Fasteners	All fasteners holding such heaters in place in unit. For details on fasteners check installation prints.
Inspect, clean and replace Front Heater Filter & Screen	Wash filter and screen. If filter cannot be washed or is damaged, the filter <b>MUST</b> be replaced immediately. If a screen cannot be cleaned, a new screen must be installed immediately.
Inspect and clean Front Heater Heater Cores	Clean carefully with compressed dry air or vacuum and a soft bristle brush. Damaged fins should be straightened with a fin comb.
Inspect and clean Heater Cores	The core should be cleaned carefully with compressed dry air or vacuum and a soft bristle brush. Damaged fins should be straightened with a fin comb to prevent airflow restrictions.
Bleed Heater System	Bleed air from heater circulation system. This procedure is done to keep system operating correctly.
Inspect, clean or replace Heater System Filter	The filter and screen are washable. If a filter cannot be washed or is damaged, the filter <b>MUST</b> be replaced immediately. If the screen cannot be cleaned, a new screen must be installed immediately. Filter may need to be cleaned or replaced more frequently in extreme dusty and dirty environments.
Clean Underseat Heaters Filter Elements	Clean dust from cores.

**Axle & Suspension, Front**

Inspect Parabolic Spring Suspension Entire Assembly	Visually inspect for damage or misalignment.
Inspect Parabolic Spring Suspension Shock Absorbers	Visually inspect for leakage or damage.

**Axle & Suspension, Rear**

Inspect Comfort Air Suspension Ride Height	Shock length, eye-to-eye: 22.68" +- .25"
Inspect & Tighten Comfort Air Suspension Shock Absorbers	Inspect for leakage or damage. Torque mount bolts to 160-180 ft lb.

Inspect & Tighten Comfort Air Suspension Torque Arm Bolts	Torque to 150–205 ft lb.
--	--------------------------

Inspect & Tighten Comfort Air Suspension U-Bolts	Torque 7/8" bolts to 400–450 ft lb. Torque 3/4" bolts to 260–320 ft lb.
---	---

---

**Cooling System**

Test Entire Cooling System	Pressure Test Cooling system.
----------------------------	-------------------------------

Clean Radiator Fins	Clean as required.
---------------------	--------------------

---

**Engine**

Test Engine Starting Aid Block Heater	
---------------------------------------	--

---

**Steering**

Inspect Hydraulic Pump Body & Seals	Inspect for leaks.
-------------------------------------	--------------------

Inspect Steering Gear Body & Seals	Inspect for leaks.
------------------------------------	--------------------

---

**Every 12 Months or 24,000 Miles**
**Brakes**

Clean Air Brakes Pop Off Valves	
---------------------------------	--

---

**Steering**

Replace Hydraulic Reservoir Filter Element	Replace element and fluid. Replace more frequently in severe operating conditions. Dexron III or approved equal.
--	--

---

**Transmission**

Replace Transmission Fluid	Use TransSynd fluid.
----------------------------	----------------------

Inspect Transmission Shift Cable	
----------------------------------	--

Inspect Transmission Vent	Clear vent of debris or obstruction.
---------------------------	--------------------------------------

---

**Every 12 Months or 50,000 Miles**
**Axle & Suspension, Rear**

Replace Rear Axle Petroleum Based Lubricant	Hypoid Gear Oil. Viscosity depends upon operating climate. See Viscosity/Temperature chart.
---	---

**Every 12 Months or 90,000 Miles****Axle & Suspension, Rear**

Replace Rear Axle Synthetic Lubricant

Viscosity depends upon operating climate. See Viscosity/Temperature chart.

**Every 24 Months or 24,000 Miles****Brakes**

Clean Air Brakes Parking Brake Valve

See Bendix Appendixes in Air Brakes Chapter.

Clean Air Brakes Quick Release Valves

See Bendix Appendixes in Air Brakes Chapter.

Clean Air Brakes Relay Valves

See Bendix Appendixes in Air Brakes Chapter.

Clean Air Brakes Spring Brake Valve

See Bendix Appendixes in Air Brakes Chapter.

**Every 24 Months or 225,000 Miles****Exhaust System**

Replace DEF Supply Module Filter

Replace DEF Tank Head Unit Filter

## Maintenance Locations

- |                                     |                            |
|-------------------------------------|----------------------------|
| 1. Intake Air Restriction Indicator | 8. Not Applicable          |
| 2. Rear Axle Lubricant              | 9. Brake Camshaft          |
| 3. Axle Vent                        | 10. Brake Slack Adjusters  |
| 4. King Pin                         | 11. Automatic Transmission |
| 5. Tie Rod                          | 12. Universal Joints       |
| 6. Drag Rod                         | 13. Driveline              |
| 7. Steering Gear                    |                            |

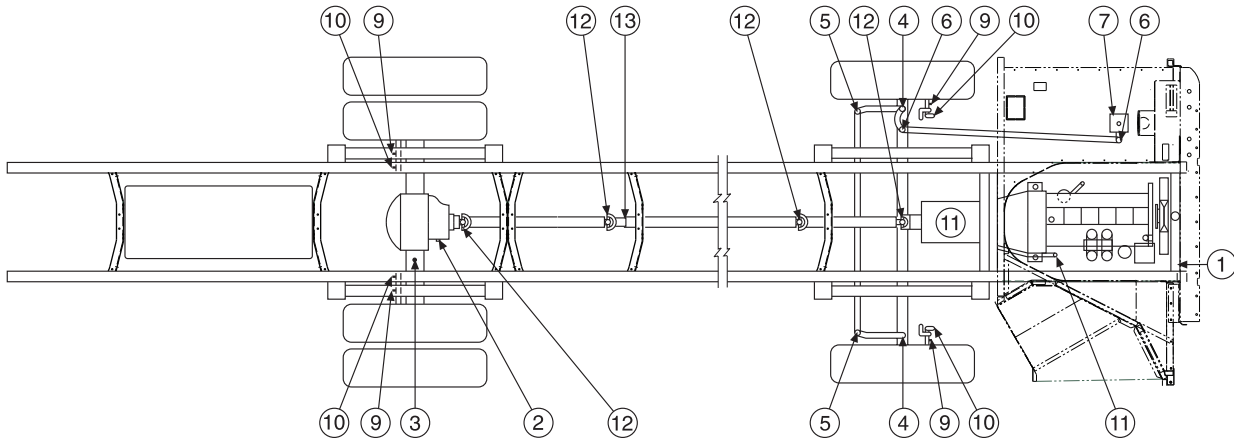

All American Front Engine

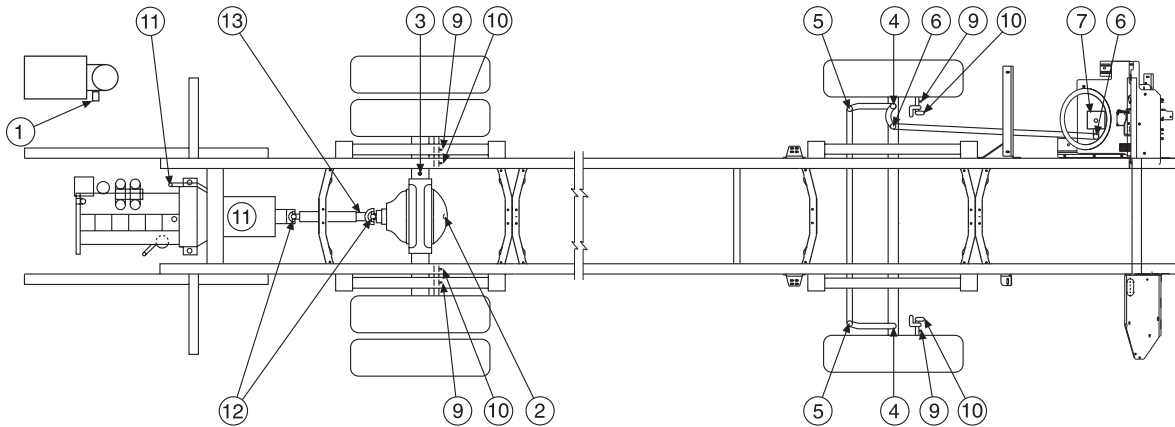

All American Rear Engine



## General Data

### Dimensions

HEADROOM: 78 INCHES  
 EXTERIOR HEIGHT: APPROXIMATELY 122 INCHES  
 EXTERIOR HEIGHT W/AC: ADD 16 INCHES  
 EXTERIOR WIDTH: 96 INCHES  
 INTERIOR WIDTH: 90.75 INCHES

### \*Fluid Capacities (In Quarts)

	Crankcase Oil	**Engine Coolant	Auto Trans. Fluid	Power Steering Fluid
Cummins ISB	19.5 w/Filter	41.0 Fixed Radiator	16.75 (2500 Transmission)	4.36 Hydraulic Brakes
		41.5 Swing Radiator	31.0 (3000 & B300 Trans.)	2.70 Air Brakes
Cummins ISC	25.2 w/Filter	66.5 (189 W.B.)	31.0 (3000 & B300 Trans.)	4.89 (189 W.B.)
		67.2 (217 W.B.)	36.0 (w/Retarder)	5.09 (217 W.B.)
		68.1 (245 W.B.)		5.29 (245 W.B.)
		68.5 (259 W.B.)		5.45 (259 W.B.)
		68.8 (273 W.B.)		5.45 (273 W.B.)
Cummins ISL	28.2 w/Filter	68.3 (189 W.B.)	31.0 (3000 & B300 Trans.)	4.89 (189 W.B.)
		69.0 (217 W.B.)	36.0 (w/Retarder)	5.09 (217 W.B.)
		69.9 (245 W.B.)		5.29 (245 W.B.)
		70.2 (259 W.B.)		5.45 (259 W.B.)
		70.6 (273 W.B.)		5.45 (273 W.B.)

\*NOTE: All fluid capacities should be re-checked to full level after initial fill, bleeding or changing.

\*\*NOTE: Engine coolant capacities are not inclusive of additional passenger compartment heater options.

### Engine Oil Pressure

CUMMINS ISB: 40–50 PSI @ 2,500 RPM, WARM

CUMMINS ISC: 40–50 PSI @ 2,500 RPM, WARM





PUBLICATION  
NUMBER  
10026202

COUNT ON BLUE BIRD



BLUE BIRD

TECHNICAL PUBLICATIONS

Post Office Box 937 • Fort Valley, Georgia 31030, USA • [www.blue-bird.com](http://www.blue-bird.com)