

D3FE

2013

DRIVERS HANDBOOK

APPLIES TO THESE MODELS

ALL AMERICAN FORWARD ENGINE

TX3 FORWARD ENGINE

GLOBAL TRANSIT FORWARD ENGINE

COUNT ON BLUE BIRD



BLUE BIRD



BLUE BIRD

D3FE



10026198
Edition A

© 2011 Blue Bird Corporation. All rights reserved.

All Blue Bird products sold for use in the United States of America and its insular areas comply with all applicable Federal Motor Vehicle Safety Standards (FMVSS) and applicable Federal ADA requirements.

Many of the components of Blue Bird buses are obtained from outside suppliers. Where maintenance and/or service information conflicts with the component manufacturer's documentation, the manufacturer's documentation prevails.

In the event of any conflict between the requirements of this publication and any applicable legal requirement, the legal requirement prevails. Technical requirements that exceed the legal requirements are not considered to conflict.

Blue Bird Corporation continually endeavors to improve its products and reserves the right to change specifications without notice and without incurring obligation. Text, illustrations, photographs, and specifications in this manual are based on information available at the time of printing. Some equipment and features shown may be optional.



INTRODUCTION

- About This Manual / 7
- Reporting Safety Defects / 8
- Noise Emissions / 8
- About 2010 Emissions Standards / 9
- Regarding Modifications / 10
- Before Placing the Bus in Service / 12

ORIENTATION

- Vehicle Identification / 13

ENTRANCE AND EXIT

- Outward Opening Door / 14
- Outward Opening (Air Door) / 14
- Emergency Pneumatic Door Release / 15
- Electric Outward Opening Door / 15
- Emergency Electric Power Door Release / 15
- Security Lock (Outward Opening Door) / 16
- Emergency Door Vandal Lock / 16
- Wheelchair Lifts / 17

DRIVER'S AREA

- Driver's Compartment / 18
- Driver's Instrument Panel / 19
- Left Switch Panel / 24
- Right Switch Panel / 26
- Heat and Air Control Panels / 28
- Steering Column / 30
- Mirrors And Adjustment / 32

SEATING

- Standard Driver's Seat / 34
- Premium Driver's Seat / 34
- Driver's Seat Belt With Shoulder Harness / 35
- Passenger Seat Belts (Optional) / 35
- Child Restraint Seats / 36

COMPARTMENTS & ACCESS PANELS

- All American Front Access / 38
- Engine Access / 39
- Additional Access Panels / 40

ENROUTE EMERGENCIES

EMERGENCY EXITS

- Transpec™ Safety Vent / 42

EMERGENCY EQUIPMENT

- Fire Extinguisher / 44
- First Aid Kit / 44
- Body Fluid Cleanup Kit / 44
- Fire Axe/Crowbar / 44
- Flare Kit / 44
- Triangular Warning Devices / 45

TIRE / WHEEL EMERGENCIES

- Spare Tire Location And Removal / 46
- Damaged Tires / 47
- Wheel And Rim Safety / 48
- Jacking Instructions / 49
- Changing a Flat Tire / 50
- Schrader Valve / 51
- Releasing Spring Brake Manually / 51
- Towing Or Pushing / 52

ROUTINE OPERATION

PRE-ROUTE INSPECTION

Weekly Inspection / 55

ENGINE OPERATION

Engine Exhaust Caution (Carbon Monoxide) / 56

Diesel Fuel / 56

Diesel Engine Starting Procedure / 57

Starting With Boost Cables / 57

Using The Engine As A Brake / 58

Engine Warning System / 58

Exhaust System / 59

DPF Regeneration In Blue Bird Buses / 60

Levels of Notification / 61

Stationary Regeneration Precautions / 64

SCR System in Blue Bird Buses / 65

TRANSMISSIONS

Allison Automatic Transmission / 71

Allison Model 3000 Series Transmission / 71

Allison Model 2000 Series Transmission / 73

Range Inhibited Light / 74

Check Transmission Light / 74

Allison Automatic Transmission Driving Tips / 75

Transmission Indicators / 76

Transmission Service Prognostics / 77

BRAKING

Antilock Braking System (ABS) / 79

Hydraulic Brakes / 79

Air Brakes / 83

HEATERS

Heater Operation / 84

Control Panel Outlet Locations / 85

Defrosting / 86

Heater Defroster Location / 86

Driver / Passenger Comfort / 86

Temperature Control / 86

Standard Heater Cut Off Valves / 87

CARE & MAINTENANCE

ELECTRICAL

Interior Lights / 90

Exterior Lights / 90

Doran Warning Light Monitor / 91

Circuit Breakers / 93

DOOR ADJUSTMENT & LUBRICATION

Outward Opening Door Adjustment / 94

Outward Opening (Air Powered) Adjustment / 94

Sliding Bolt Vandal Lock / 95

Security Lock Lubrication (Outward Opening Door) / 95

Access Doors / 95

SEATING CARE

Seat Belt Inspection And Maintenance / 96

Seat Inspection And Maintenance / 96

SIGNS & SIGNALS

Stop Arms / 100

Destination Signs / 101

ENGINE & RUNNING GEAR

Air Intake System Inspection / 102

Engine Cooling System / 103

Shutters / 105

Transmission / 106

Rear Axle / 106

Hydraulic Brakes / 106

WINDSHIELD WIPERS

Washer Solution Reservoir / 107

Wiper Assembly Replacement / 107

HEATER CARE

Annual Maintenance / 108

Cleaning Auxiliary Fans / 109

CLEANING

Exterior Cleaning / 110

Floor Cleaning / 112

MAINTENANCE SCHEDULE

Maintenance Task Schedule, D3FE / 113

Maintenance Locations / 128

General Data / 129





Thank you for selecting the Blue Bird All American. The All American is the culmination of almost a century of Blue Bird heritage in student and public transportation which began in 1927. As always, the design and construction of the All American reflects Blue Bird's concern for safety, efficiency, and quality.

About This Manual

This Drivers Handbook has been prepared to acquaint you with the operation of the Blue Bird All American, and should be read by all Drivers before operating the unit. Familiarity with automotive operation and control is assumed to be common knowledge to all who will be operating this bus. This book does not address all driving situations which may arise, and it is not a substitute for proper driver training. It will, however, enable a School Bus driver to more quickly feel at home in this model All American.

Your Blue Bird All American may not have all of the equipment described in this manual. You may find information on optional equipment not installed on your bus. You are encouraged to contact your Blue Bird distributor if additional information or assistance is needed.

For use as a convenient reference, this Handbook also contains some general maintenance information. Although the Driver will not likely be performing service procedures, this information nonetheless serves to further familiarize the Driver with the bus. The maintenance information contained herein is provided as a reference for systems and components that require periodic service. The intervals given are component manufacturers' recommendations and should be considered maximum intervals; that is, the very minimum maintenance schedules that will afford reasonable care of this vehicle. Service technicians should refer to the Service Manual for more complete service information. If this manual does not address your specific questions or concerns, please contact your Blue Bird distributor. The distributor will answer your questions or put you in contact with the proper factory personnel.

Throughout this manual are precautions labeled Warnings and Cautions, and set in the style shown here:

WARNING *The Warning designation is generally used for precautions which, if not properly observed while performing the related procedures or handling materials, could result in serious personal injury or death.*

CAUTION *The Caution designation is generally used for precautions which, if not properly observed while performing the related procedures or handling materials, could result in damage to the bus or its equipment.*

For the terms of the Limited Warranty of this Blue Bird product, refer to the Warranty certificate provided in the owner's documents that came with the vehicle.

This manual provides you with the most current operation information available. We welcome your comments and suggestions regarding this manual. Please direct all correspondence to:

*Blue Bird Corporation
Attn: TECHNICAL PUBLICATIONS
P.O. Box 937
Fort Valley, GA 31030*

Reporting Safety Defects

If you believe that your vehicle has a defect which could cause a crash or could cause injury or death, you should immediately inform the National Highway Traffic Safety Administration (NHTSA) in addition to notifying Blue Bird.

If NHTSA receives similar complaints, it may open an investigation and, if it finds that a safety defect exists in a group of vehicles, it may order a recall and remedy campaign. However, NHTSA cannot become involved in individual problems between you, your dealer, or Blue Bird Corporation.

To contact NHTSA, you may call the Vehicle Safety Hotline toll-free at:

1-888-327-4236 (TTY: 1-800-424-9153)

or go to:

<http://www.safercar.gov>

or write to:

Administrator, NHTSA,

400 Seventh

Street, SW., Washington, DC 20590

You can also obtain other information about motor vehicle safety from:

<http://www.safercar.gov>.

Noise Emissions

This vehicle was designed, built, and equipped by Blue Bird to conform to all applicable United States Environmental Protection Agency Noise Control Regulations.



About 2010 Emissions Standards

Buses equipped with 2010 diesel engines are designed to conform to stringent federal emissions standards. These standards affect both the equipment installed at the factory and the fuel at the pump.

Buses powered by 2010 emissions standards engines are equipped with special exhaust systems to reduce emissions. The technical details of the systems employed by various engine manufacturers differ, but share common general principles. The exhaust muffler is replaced by a diesel particulate filter which traps and burns microscopic particles in a process referred to as “regeneration.” When heat in the exhaust is insufficient to fully burn the particulates, the system enters an “active” regeneration mode so the necessary catalytic reaction can take place. During active regeneration events, exhaust temperatures are elevated, and an indicator light on the instrument panel illuminates to notify the Driver that regeneration is active. This regeneration mode is automatic and normal, and requires no special action on the part of the Driver. If driving conditions have resulted in insufficient active regeneration then a “manual” regeneration may be required to clean the filter. If this condition occurs an indicator will alert the driver and a maintenance technician should be notified.

Removing particulate matter (soot) from the exhaust stream through regeneration alone will not satisfy the more stringent 2010 emission standard. This standard requires reduced levels of Nitrogen Oxides (NOx). To achieve this a Selective Catalytic Reduction system (SCR) is added downstream of the diesel particulate filter. The SCR system uses a chemical reactant – Diesel Exhaust Fluid (DEF) – which converts to ammonia in the exhaust stream and reacts with NOx to form harmless nitrogen gas and water.

Fuel Requirements: As part of the 2007 emissions standards, effective October 15, 2006 the EPA has required fuel retailers to sell lower-emission fuel, designated “ultra-low-sulfur diesel”. After that date, all commercially-available number 1 and number 2 highway diesel fuels are Ultra-low-sulfur diesel. This fuel must be used in all 2013 model buses powered by a diesel engine, as indicated by a decal located near the fuel filler door, reading:

Ultra Low Sulfur Diesel Fuel Only.

For detailed information on recommended fuels and other fluids, always follow your engine manufacturer’s guidelines. Also see, Cummins Bulletin No. 3379001.

Regarding Modifications

Blue Bird Corporation offers many items as standard and optional equipment to meet federal, state, and local specifications and individual customer requirements. This includes, but is not necessarily limited to, stop arms, crossing guards, warning lights, warning light monitors, mirrors, first aid kits, fire extinguishers, warning reflectors, fuses, directional and brake lights, warning buzzers, security/vandal locks, emergency exits, and seat belts.

Emergency equipment must be checked for proper operation daily. It is the driver's responsibility to report any damage to qualified service technicians, and that the condition be corrected before transporting passengers.

Those interested in modification of this vehicle should consult the Service Manual and Blue Bird Engineering Department for a more complete understanding of the vehicle.

WARNING *Vehicle alterations, which may cause non-conformance with the Emission Control and/or Federal Motor Vehicle Safety Standards (FMVSS), are expressly not authorized by Blue Bird Corporation. It is the responsibility of the entity undertaking the modification of this product to ascertain compliance with all applicable regulations. Modification must be accomplished in accordance with strict government standards. The entity completing modification of this product must certify that all applicable regulations are met. To certify a modified vehicle, the upfitter must be a licensed vehicle manufacturer, or obtain the services of a licensed vehicle manufacturer for that purpose. Specifically, Blue Bird does not authorize the following modifications.*

- Do not modify the Front or Rear Suspension
- Do not modify the Wheelbase length
- Do not modify or remove the Body or Chassis Crossmembers
- Do not modify the Frame Rail Flanges
- Do not weld on the Engine, Radiator, Fuel Tank(s), Transmission or any component of those items
- Do not modify the Cooling System / Air Intake
- Do not modify the Exhaust / Emission system
- Do not modify the Brake System
- Do not modify the Steering System
- Do not modify the Electrical System and Lights
- Do not modify or obstruct the Mirrors
- Do not modify the Seats
- Do not install any equipment or component nearer than 2 inches (51mm) to the fuel tank(s), rotating components or "jounce" movement of driveline components
- Do not install any equipment or component that will obstruct the flow of air into, around, or from the cooling system
- Do not install any equipment, components, including flooring and/or carpeting, which will obstruct the functioning of the brake and accelerator pedals



For the terms of the Limited Warranty of this Blue Bird product, refer to the Warranty certificate provided in the owner's documents that came with the vehicle.

In addition to the safety issues involved in the modification of the unit, any "unauthorized" modification may adversely affect the warranty of this product by Blue Bird Corporation.

CAUTION *All Blue Bird products are certified to meet or exceed all applicable motor vehicle regulations and standards in the "as purchased" configuration. Any modifications are the responsibility of the entity making those modifications. Blue Bird engineering does not authorize any modification of the vehicle.*

The complete line of Blue Bird Service Parts is available from your Blue Bird Dealer. The use of original Blue Bird replacement parts and components will help ensure that your All American remains true to its original design, best preserving performance, efficiency, and safety.

For replacement parts. . .

Contact your Blue Bird distributor or Parts Sales at Blue Bird Corporation.

Before Placing the Bus in Service

It is the responsibility of the bus Owner/Operator to ensure compliance with all federal, state, and local regulations for school bus operation and equipment. As part of a daily pre-trip inspection, the Driver should consider it his/her responsibility to verify that the vehicle is in satisfactory working order and that all emergency equipment is in place, fully stocked (First Aid Kit), up-to-date (Fire Extinguisher), and in proper working condition.

- Check the suspension U-bolt torque.
- Check the service brake adjustment.
- Check the park brake adjustment on units equipped with hydraulic brake systems.
- Check the torque on all the body "tie-down" capscrews.
- Check the engine oil level.
- Check the transmission fluid level.
- Check the engine coolant level.
- Check the air pressure in all the tires.
- Check the torque on the driveline universal joint straps.

Inspection guidelines from individual state inspection manuals (such as Commercial Driver's License pre-trip inspection procedures) take precedence over those found in this manual. Guidelines found herein are in addition to those in your state's inspection requirements.

The Driver is responsible for determining that the loading area is clear before stopping to load passengers. The Driver must ensure that all unloaded passengers are clear before moving the bus.

WARNING *Emergency equipment must be checked for proper operation daily. It is the Driver's responsibility to report any damage to qualified Service Technicians and to ensure that the condition is corrected before transporting passengers.*



This section is to familiarize the Blue Bird All American Driver with the locations of controls and other bus features with which he or she will interact daily.

Vehicle Identification

The **Vehicle Certification Plate** certifies that the vehicle conforms to all applicable Federal Motor Vehicle Safety Standards in effect at the date of manufacture. Do not remove or deface this plate.

MANUFACTURED BY		BY	
BLUE BIRD BODY COMPANY			
DATE OF MFR.		[]	
INC. VEH. MFG. BY	[]	DATE	[]
SUITABLE TIRE - RIM CHOICE			
GVWR	[]		
GVWR : FRONT	[]	WITH	[] TIRES
	[]	RIMS, AT	[] PSI COLD SINGLE
GVWR : REAR	[]	WITH	[] TIRES
	[]	RIMS, AT	[] PSI COLD DUAL
THIS VEHICLE CONFORMS TO ALL APPLICABLE FEDERAL MOTOR VEHICLE SAFETY STANDARDS IN EFFECT IN []			
V.I.N.	[]	CLASSIFICATION	[]

The **Body Serial and Service Number Plate** is located on the front upper inner panel above the windshield. Refer to the data on this plate for registration purposes or for replacement part information.

	BLUE BIRD
	BLUE BIRD FORT VALLEY
FORT VALLEY, GEORGIA	
BODY NO.	[]
MODEL YEAR	[]
MFG. BODY DATE	[]
STATE / PROVINCE	[]
EQUIPPED CAPACITY	[]
SPECIFICATION YEAR	[]
MAX. DESIGN CAPACITY	[]
BODY SERVICE NO. []	

The **Axle Record and Chassis Service Number Plate** is located on the front upper inner panel above the windshield. Refer to the data on these plates for registration purposes or for replacement part information.

FURNISH INFORMATION BELOW WHEN ORDERING AXLE PARTS			
CHASSIS SERIAL	[]	ENGINE SERIAL	[]
FRONT AXLE	[]	BRAKE LINING FMSI NO. & FRICTION CODE	[]
BRAKE DRUM	[]		[]
REAR AXLE	[]	BRAKE LINING FMSI NO. & FRICTION CODE	[]
BRAKE DRUM	[]		[]
REAR AXLE RATIO	[]		[]
CHASSIS SERVICE NO. []			

ENTRANCE AND EXIT

Outward Opening Door

Outward Opening Doors are mounted in a prefabricated framework, which eliminates the effect of body construction variations on door and seal operation. Doors are suspended completely on sealed ball bearings located at the top corners of the framework, inside the body. The interlink connection between the doors is a single assembly with oppositely threaded, spherical bearing rod end connectors at each end, providing simple link length adjustment without disassembly. The geometry of the mechanical link between the doors causes the rear door to close well ahead of the front door, so that the front nosing seal rubber always overlaps the rear. Oil impregnated bronze bearings in the lower corners of the framework serve as pivots (not supports). All controls and mechanisms and the complete lower step tread are sealed inside the bus and out of the weather when the door is closed.

The manual control is the Blue Bird over center locking type with built in Saf Latch. The door's ease of operation allows use of a short handle arm, so the handle is six inches closer to the driver in the open position than with the jack-knife door.

Your bus's outward opening door may be actuated by an optional electric control connected to a lever on the front door panel. Mechanically operated switches control automatic stop positions as well as stepwell and warning lights.

Outward Opening (Air Door)

The pneumatic actuator is a cylinder connected to a lever on each door, located inside the header cover. An interconnecting link between the doors controls the operation sequence. A safety release valve is located over the door. Air switches inside the header cover operate Stepwell lights. A three position spring loaded switch signals a valve controlling the flow of air to open or close the doors. Air pressure holds the door either open or closed. The operation speed is adjustable by use of flow control valves located on the actuator



Emergency Pneumatic Door Release

An emergency release valve is located above the door in the header cover. To use the emergency release, push the lever in the direction of the arrow. This valve exhausts air pressure in the door cylinder, allowing the door to be opened and closed manually.

Electric Outward Opening Door

The electrically operated outward opening door has a gear box that moves a lever attached to the front door. To open the door, hold the spring-loaded switch in the driver's area in the "OPEN" position until the door stops moving. An automatic switch stops the action of the door. To close the door, move the switch to the "CLOSE" position; the door will stop automatically when fully closed. There is a keyed switch on the outside of the body, on the cowl panel by the door, which operates the door from outside the bus.

Emergency Electric Power Door Release

With the door in the fully closed position, pull the release lever in the header panel toward OPEN as far as possible. The linkage will release and the lever will "snap" into a "park" position so it will not return forward when released. Push the door open to exit the bus. To reset the release mechanism, move the lever to its rearward position, and hold the driver operated spring-loaded switch in the "open" position until it clearly engages, or until door is in the fully open position.



Air Door Emergency Release



Electric Door Emergency Release

Security Lock (Outward Opening Door)

Outward opening doors have an optional key locking mechanism, accessible from outside the bus. A key operated bolt slides into a hole in the header when the door is in the closed position and locked. This option also requires use of the hinged stop on the door control.

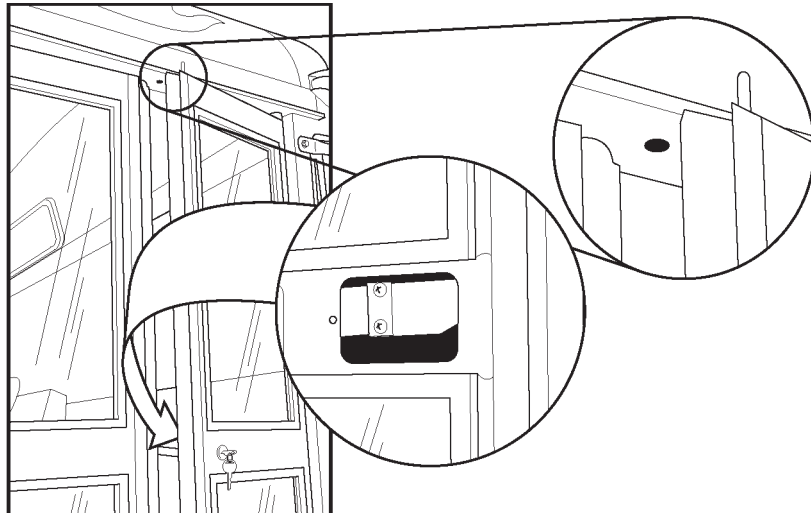

Manual Security Lock (interior)

Emergency Door Vandal Lock

The emergency door and the rear emergency window may have an optional vandal lock feature, which prevents entry through the emergency exit. There are two types of locking mechanisms; a Cylindrical Key Lock and a Sliding Bolt Latch lock. These locks will prevent the emergency exit from being opened from the outside.

The bus will not start if an emergency exit is locked. An audible buzzer will notify the driver of the locked condition. The Cylindrical Key Lock type mechanism can be unlocked by using the key to remove the cylinder and placing it in the receptacle at the side of the door. For the Slide Bolt Latch lock, simply move the latch to the unlock position. Unlocking the exit in this manner will activate a microswitch which will allow the bus to start. If a lock is activated while the engine is running, an alarm will be activated in the exit and driver's area.

WARNING *The bus must not be operated with the emergency exit locked.*



Wheelchair Lifts

Blue Bird All American school buses may be fitted with lifting platforms designed to aid in loading and unloading passengers. There are two optional wheelchair lifts available. The units available are the Ricon™ and the Braun™. Both offer a maximum of 48 inches (122 cm) lift from the ground to the level of the bus floor. For the correct operation and maintenance of the wheelchair lift on your bus, please refer to the operator's manual supplied by the OEM.

WARNING *Operators should familiarize themselves with the lift manufacturer's operator's manual prior to loading passengers on the lift. All lifts have maximum weight limits that should never be exceeded.*

These lifts are operated by an independent, electro-hydraulic power system and are controlled by the operator from outside the bus. There is a master switch located in the driver's area that must be activated as well.

The bus electrical system powers a hydraulic pump, internal to the lift, which moves the lift up. The "down" function is gravity type and is controlled by pressure relief valves. Manual operation of the "down" function requires that the operator manually control the pressure relief valves. To provide for the manual "up" function, the lift is fitted with a hand operated hydraulic jack, located on the right-hand (from inside the bus) side of the lift assembly.

A buzzer sounds when the door is unlatched or partially opened. The buzzer stops if the door is completely open.

DRIVER'S AREA

Driver's Compartment

1. See Driver's Instrument Panel.
2. See steering column with horn and controls.
3. Automatic transmission shift control range selector or electronic push button pad location.
4. See Left switch panel.
5. See Right switch panel.
6. Driver's storage compartment.
7. Driver's seat.
8. Brake pedal or air treadle - applies service brakes.
9. Accelerator pedal - controls engine speed.
10. See Heater and defroster controls.
11. Radio with optional PA system.
12. Drink cup holder. (Optional)
13. Park brake control applies parking brakes. For air brakes only.
14. Air conditioning control panel.
15. PA system interior/exterior switch.
16. PA microphone.
17. Driver's Fresh Air Intake - Push or pul to open and close vent.
18. Parking Brake Release handle. Hydraulic brakes only.
19. Parking Brake - Hydraulic brakes only.

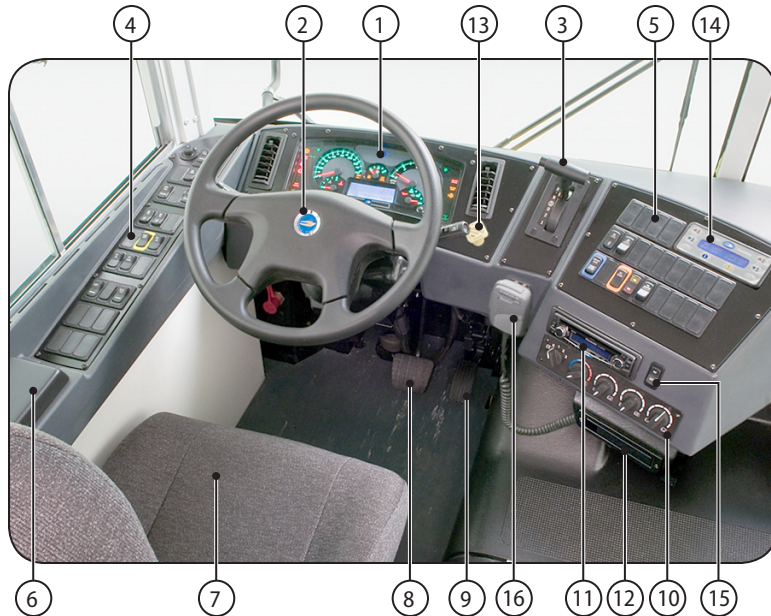

Above Windshield (Item not indicated)

- Auxiliary fans
- Interior rearview mirror
- First aid kit
- Identification plates

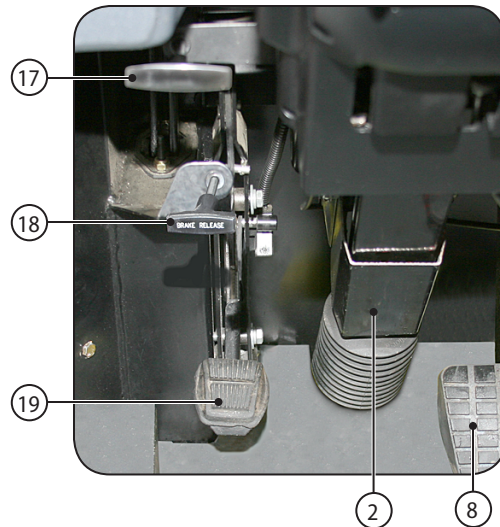



Driver's Instrument Panel

- Speedometer.** Indicates vehicle speed in miles/hour or kilometers/hour.
- Tachometer.** Indicates engine speed in revolutions per minute times 1000.
- Message Display Center.** Displays additional information to the vehicle operator. See Message Display Center.
- Fuel Gauge.** Indicates fuel level in tank. Fuel gauge bank includes illuminated Low Fuel Indicator and Low Fuel Pressure Indicator.
- Coolant Temperature Gauge.** Indicates engine coolant temperature and includes an engine coolant temperature warning indicator.
- Oil Pressure Gauge.** Indicates engine oil pressure and includes an oil pressure warning indicator.
- Front Air Gauge.** Indicates air pressure in front brake reservoir and includes a low air warning indicator. (Air Brakes only.)
- Rear Air Gauge.** Indicates air pressure in rear brake reservoir and includes a low air warning indicator. (Air Brakes only.)
- Left Warning Bank.** Cluster of indicator lamps. See Warning Bank Indicators.
- Right Warning Bank.** Cluster of indicator lamps. See Warning Bank Indicators.
- Message Display Center Control Panel.** Two buttons which activate and toggle the menus of the Message Display Center.
- Headlight Highbeam Indicator.**

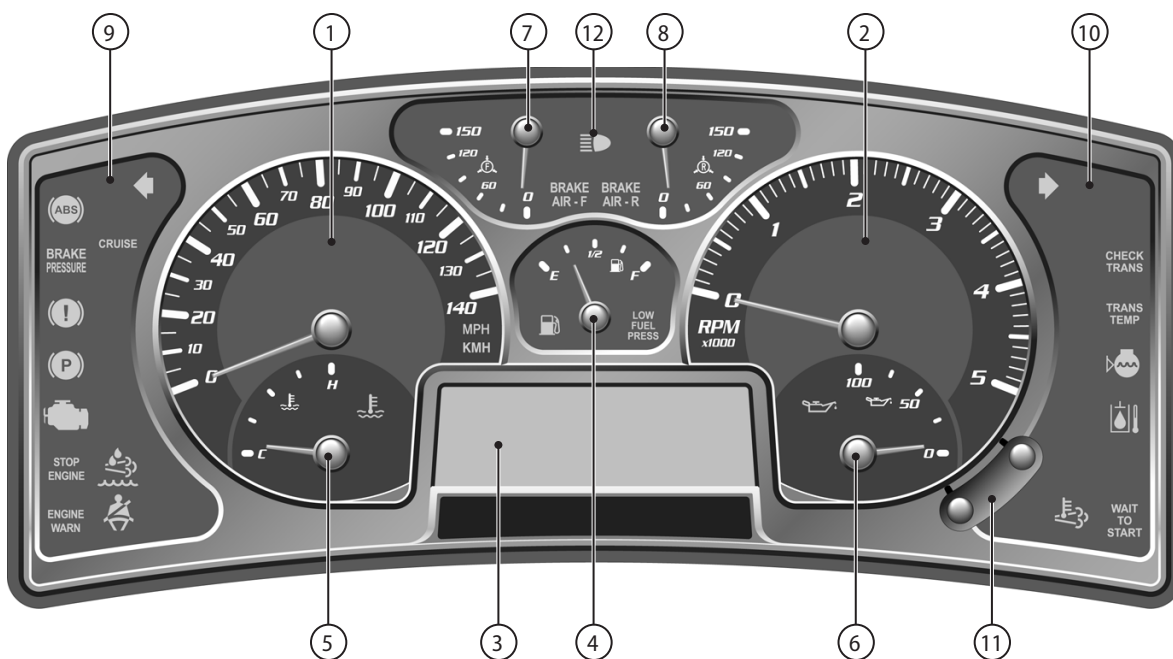

Message Display Center

The message display center provides additional information to the vehicle operator. It is a Liquid Crystal Display (LCD) screen located at the bottom center of the instrument panel and is divided into four quadrants. Each quadrant displays specific data relayed to the vehicle operator from vehicle systems. The message display center can also be used for diagnostic purposes by trained service technicians. The four quadrants of the display are selected and toggled by the two buttons on the message display control panel on the lower right side of the tachometer.



Message Display Control Panel

QUAD 1	QUAD 2A
	QUAD 2B
QUAD 3	QUAD 2C
	QUAD 4

Quad 1. Displays the Odometer, Trip 1 Odometer and Trip 2 Odometer. The odometer registers the mileage on the vehicle and the trip odometers may be set to register mileage from destination to destination. On the message display control panel press and release the top button to toggle between the odometer, and trip 1 and trip 2 odometer settings. Press and hold the top button to reset the trip odometer. After the bus has been turned off the odometer reading can be displayed by activating the headlights or by pressing either the top or bottom button. This quadrant also displays all general priority messages when triggered. In most cases, the priority message will flash between forward and reverse video. The priority messages can be acknowledged by pressing the bottom button or cycling the ignition. This will allow you to return Quad 1 to the previous display until the recurrence time-out, next ignition or the trigger logic is not satisfied. Any lamps associated with the acknowledged message will remain on until the fault is gone or the ignition is turned off. If multiple messages are present, they will cycle every two seconds.

Quad 2A. Displays Gear Selection. **P** - Park, **N** - Neutral, **R** - Reverse, and **D** - Drive.

Quad 2B. Displays alternator output voltage (in Volts) and depending on option, can display the amount of current being drawn by the vehicle electrical system (in Amps).

Quad 2C. Displays the transmission temperature. On buses equipped with and configured for air brakes the service brake pressures will be displayed, temporarily replacing the transmission temperature. This shows how much air pressure in psi (pounds per square inch) is being applied to the front and rear brakes when the brake pedal is pressed. On busses equipped and configured for hydraulic brakes, the transmission temperature will be temporarily replaced with the rear suspension air pressure when the service brakes are applied, if enabled. When the service brakes are not applied Quad 2C will return to Transmission Temperature.

Quad 3. Displays the diesel exhaust fluid (DEF) gauge. The DEF level is displayed as a percent of full tank (15 gallons) capacity.

Quad 4. Displays a clock. This clock can be displayed in either a 12 or 24 clock mode. This mode can be toggled by pressing and releasing the bottom button until Quad 4 is activated, then press and release both buttons simultaneously to highlight the quadrant in reverse video. Toggle between the two modes by pressing and releasing the top or bottom button. *Note: This quadrant configuration is for busses equipped with a 2010 emission compliant diesel engine (i.e. ISB10/ISC10). Busses equipped with an optional engine such as an export engine (i.e. ISB03/ISB05) may display information in alternate quadrants.*

Priority Messages

- No Engine Communication
- No Transmission Communication
- No ABS Communication
- Data Link Warning
- Vehicle Speed Error
- Engine Door Open
- Brake Interlock Set
- Brake Interlock Fail
- Brake Interlock Requested
- Retarder Applied
- DEF Level Low
- DEF Level Critical
- DEF Level Derate
- DEF Level Empty
- DEF Speed Limit
- DEF Fluid Type
 - * Stop Engine
 - * Engine Warning
 - * Hi Trans Temp
 - * Low Oil Pressure
 - * High Engine Temp
 - * Low Coolant Level
 - * Turn Signal On
 - * Voltage Error
 - * Water In Fuel
 - * Lift Not Stowed
 - * Regen Needed
 - * High Exhaust Temp
 - * Alternator Fail
 - * Headlights On
 - * ATC Active
 - * Range Inhibit
 - * Transmission Oil Life
 - * Trans Oil Filter
 - * Transmission Oil Service

* (Messages Shown with Icon)



Warning Bank Indicators

Two arrangements of LED-illuminated warning lights provide feedback to the Driver about various systems. These are located to the right and left sides of the instrument panel. Indicator definitions are shown below.

An audible speaker is incorporated into the back of the instrument cluster, and sounds to accompany the indicator light warnings. The audible alarm also serves to indicate turn signal blink and turn signal reminder.

- | | | | | | |
|------------------------------|--|------------------------------|--|-----------------------------|--|
| | <p>Left Turn. Flashes with left turn signal.</p> | | <p>High Beam. Headlights are in high beam.</p> | | <p>Right Turn. Flashes with right turn signal.</p> |
| | <p>ABS. Indicates fault in the anti-lock brakes system.</p> | <p>CRUISE</p> | <p>Cruise. Cruise control has been activated.</p> | <p>CHECK TRANS</p> | <p>Check Trans. The transmission needs service.</p> |
| <p>BRAKE PRESSURE</p> | <p>Brake Pressure. Indicates brake failure. Stop vehicle and call for assistance.</p> | <p>BRAKE AIR - F</p> | <p>Brake Air Front. Indicates front brake air pressure outside of normal operating range.</p> | <p>TRANS TEMP</p> | <p>Trans Temp. The transmission temperature is beyond normal operating range.</p> |
| | <p>Brake Alarm. Indicates a problem with the service brakes (metric units only).</p> | <p>BRAKE AIR - R</p> | <p>Brake Air Rear. Indicates rear brake air pressure outside of normal operating range.</p> | | <p>Coolant Level. Indicates low coolant level.</p> |
| | <p>Park. Indicates parking brake is applied.</p> | | <p>Low Fuel. Indicates fuel level at 12 percent of maximum capacity.</p> | | <p>Hydraulic Fluid Temperature. The hydraulic fluid temperature is beyond normal operating range. (Rear Engine only)</p> |
| | <p>Maintenance Indicator Lamp. Indicates engine maintenance required.</p> | <p>LOW FUEL PRESS</p> | <p>Low Fuel Pressure. Indicates low fuel pressure on compressed natural gas vehicles.</p> | <p>WAIT TO START</p> | <p>Wait to Start. Indicates engine preheating. Wait until indicator goes off before starting engine.</p> |
| <p>STOP ENGINE</p> | <p>Stop Engine. The engine ECU has detected a problem which can lead to engine damage. Stop the engine and call for assistance.</p> | | <p>High Coolant Temp. Indicates coolant temperature out of normal operating range.</p> | | <p>HEST. High Exhaust System Temperature. Indicates elevated exhaust temperature. See <i>Exhaust System</i> under <i>Routine Operation</i>.</p> |
| <p>ENGINE WARN</p> | <p>Engine Warn. The engine needs service.</p> | | <p>Seat Belt. Indicates driver seatbelt not engaged. (Optional)</p> | | <p>Oil Pressure. Indicates low oil pressure.</p> |
| | <p>Diesel Exhaust Fluid. DEF low level warning light. See <i>SCR System in Blue Bird Buses</i> under <i>Routine Operation</i>.</p> | | | | |

Set the Clock

To set the clock, be sure the park brake is set then press and hold the bottom button on the face of the instrument cluster for approximately 5 seconds. This will display the Settings and Diagnostics screen. Press either the top or bottom button to move to the highlighted bar to menu item 6 – Set Clock. Press both buttons simultaneously to select “hours” then use the upper and lower buttons to increase or decrease the setting. Press both buttons simultaneously to set the hours. Repeat the process for the “minutes” setting. A lapse of ten seconds or more of inactivity will return the display to the previous screen automatically.

Dimmer Adjustment

Dimming or brightening the backlight in the instrument cluster can be accomplished two ways. The first is when the bus is stationary with park brake set. The second is in Drive Mode when the park brake is released and the headlight switch is in the “ON” position. In either case the new setting will be stored in memory.

When the bus is stationary and the park brake is set, dimming the instrument cluster is achieved through a menu in the drivers display in the cluster. Set the park brake then press and hold the bottom button on the face of the instrument cluster for approximately 5 seconds. This will display the Settings and Diagnostics screen. Press either the top or bottom button to move the highlighted bar to menu item 4 – Dimmer. Press both buttons simultaneously to select “dimmer” then use the upper and lower buttons to increase or decrease the backlight intensity. Press both buttons simultaneously to set the dimmer and exit the menu. A lapse of ten seconds or more of inactivity will return the display to the previous screen automatically.

If the bus is in drive mode by having the park brake released, the dimmer can be adjusted by pressing either the top or bottom buttons to brighten or dim the instrument cluster. The headlight switch must be in the “ON” position for this function to operate.



Message Display Control Panel

**Contrast Adjustment**

Set the park brake then press and hold the bottom button on the face of the instrument cluster for approximately 5 seconds. This will display the Settings and Diagnostics screen. Press either the top or bottom button to move the highlighted bar to menu item 3 – Contrast. Press both buttons simultaneously to select “contrast” then use the upper and lower buttons to increase or decrease the contrast. Press both buttons simultaneously to set. A lapse of ten seconds or more of inactivity while in this mode will return the display to the previous screen automatically.

Backlight Color Adjustment

The backlight color can be adjusted to illuminate in any of five different colors (Red, Green, Blue, Lt Blue, White). To change the backlight color set the park brake then press and hold the bottom button on the face of the instrument cluster for approximately 5 seconds. This will display the Settings and Diagnostics screen. Press either the top or bottom button to move the highlighted bar to menu item 5 – BL Color. Press both buttons simultaneously to select “BL Color” then use the upper or lower buttons to toggle between a list of preset colors. Press both buttons simultaneously to set the color and exit the menu. A lapse of ten seconds or more of inactivity while in this mode will return the display to the previous screen automatically.

Left Switch Panel

The left switch panel located under the driver's side window and shown here consist of the exterior rearview mirror controls and switches for standard and optional equipment. The left switch panel will be equipped only with switches for options that are included on your bus and therefore may differ from the panel shown here. The following is a list of switches and indicators and their descriptive icons.



Right and left rearview mirror remote control.



Headlight and parking lights.



Exterior rearview mirror defrost.



Park lights.

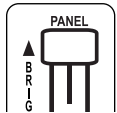

Interior panel dimmer.



Left, center and right auxiliary fans. High, low, and off positions.



Destination sign.



Open fuel door indicator light.



Brake interlock override. Momentary switch. Overrides brake interlock system.



Noise suppression. Includes yellow bezel. Momentary or on/off. Turns off all heaters, fans and radio to allow the driver to hear sounds outside the bus; for instance, at a railroad crossing.



Variable geometry turbo brake. Helps slow engine speed.



Driver's dome light.



High idle. Engages high idle.



Left side dome lights.



Tire chains.



Right side dome lights.



Rear dome lights.



Lift. Provides power for lift operation.



Lift door open indicator light.



Emergency door open indicator light.

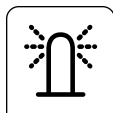

Strobe light.



Roof vent fan. High, low, and off positions.



Chimes. Provides power for passenger compartment chime system.



Left side landing lights.



Right side landing lights.





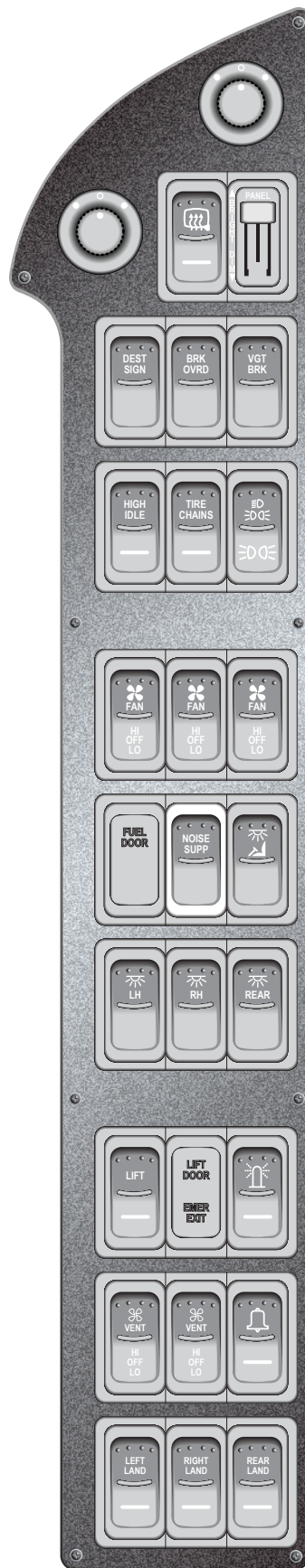





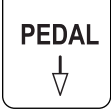

Rear landing lights.



Right Switch Panel

The right switch panel as shown here consists of switches and controls for optional equipment installed on the bus. There are three banks of switches. The first bank of switches are for optional equipment that may be installed. The second bank of switches control heater options installed. Heater options are installed according to option priority, therefore, the switches in this bank may or may not appear in the positions shown. The third bank of switches controls warning lights. These switches and indicators are also installed by option priority so, switch locations in this bank may vary also. If this unit is equipped with optional air conditioning, the control panel will be located as shown on the upper right side of this panel. The air conditioning control panel will be defined later in this publication. The following is a list of switches and indicators and their descriptive icons.

- | | | | |
|---|--|---|--|
|  | <p>Pedal Adjustment. Allows forward and rearward movement of the accelerator and brake pedal. Provides a 3 inch range of movement.</p> |  | <p>Driver's heater fan. High, off and low positions.</p> |
|  | |  | <p>Heater pump. Provides supplemental heat to the passenger compartment.</p> |
|  | <p>Kneeling feature. Allows front of bus to be lowered and raised for passengers to embark or disembark more easily.</p> |  | <p>Rear heater fans. High, off and low positions.</p> |
|  | |  | <p>Front heater fans. High, off and low positions.</p> |
|  | <p>Kneel feature indicator light. Kneeling feature has been initiated.</p> | | |
|  | <p>Luggage door open indicator light</p> | | |



SERVICE DOOR Air or electric entrance door switch with blue bezel.

W/L START Warning light start with orange bezel. Initiates warning light sequence

W/L MASTER Warning light master. Enables entire warning light system.

W/L Warning light indicators. Red and yellow.

S/C ARM CANCEL Stop arm and/or crossing arm cancel. Interrupts stop arm and/or crossing arm sequence.

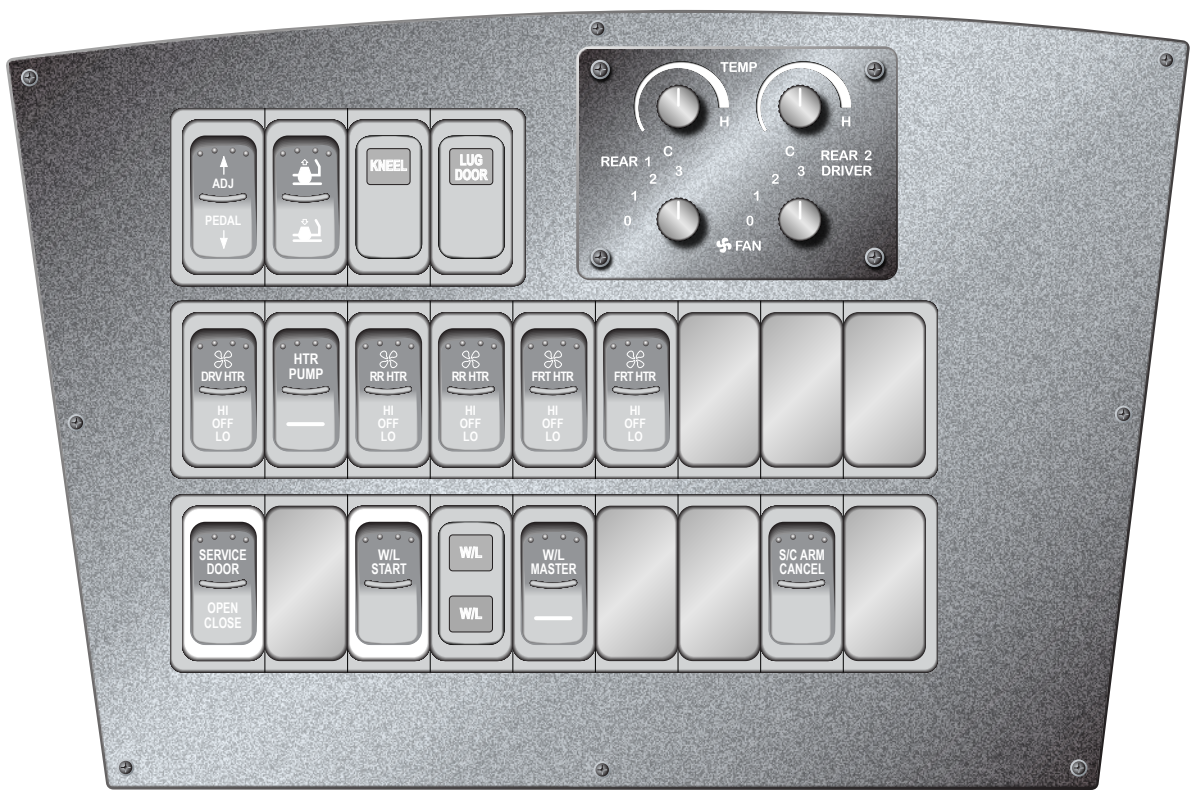

Heat and Air Control Panels

The heat and air control panels are defined below. For further explanation of heaters and heater controls, see Heaters, under Routine Operation found in this manual. For additional information on optional air conditioning, see your Comfort Aire publication supplied with your air conditioned bus.

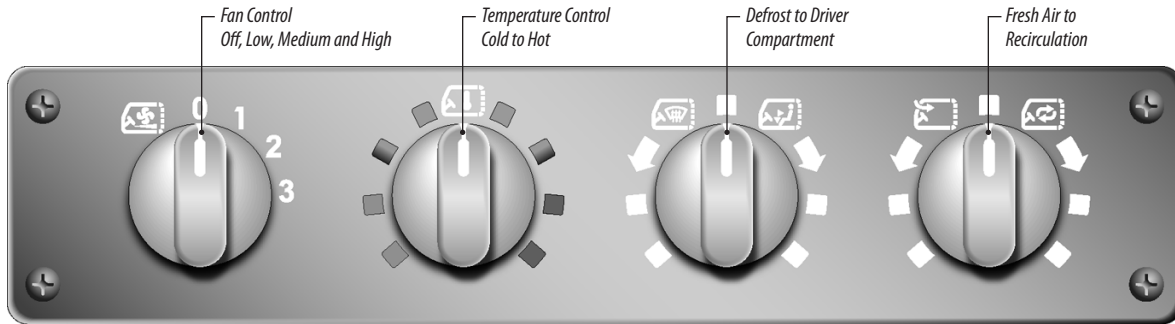

Blue Bird Heater Control Panel



Temperature Controls
(Upper Knobs)
Off, Low, Medium and High

Fan Controls
(Lower Knobs)
Off, Low, Medium and High

Comfort Aire Manual Controls

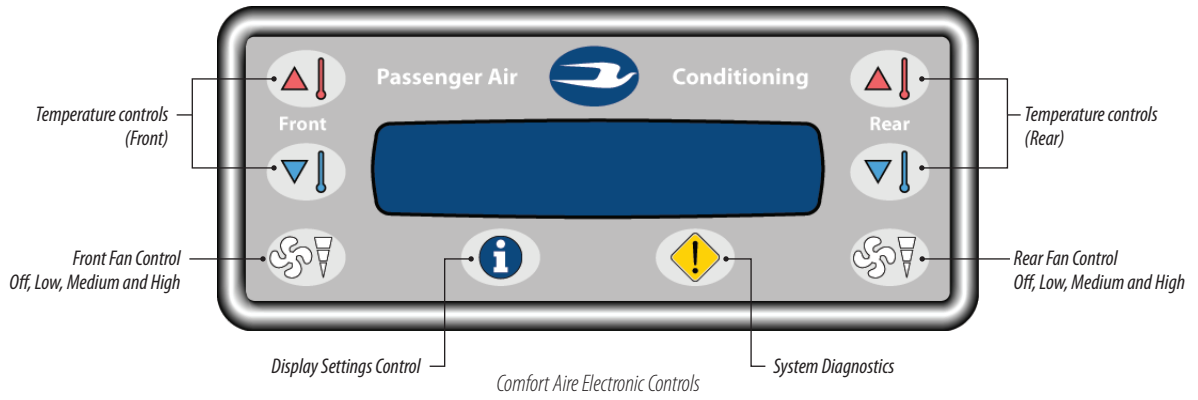

Temperature controls
(Front)

Front Fan Control
Off, Low, Medium and High

Display Settings Control

Comfort Aire Electronic Controls

System Diagnostics

Temperature controls
(Rear)

Rear Fan Control
Off, Low, Medium and High

Steering Column

The steering column of the new All American is designed for better access to the driver's area with easier adjustment and a greater range of movement.

Steering Wheel Position

A lever at the lower side of the column sets the tilt and telescopic adjustment of the steering wheel. This is a two position lever. Pull it out to the first position to adjust tilt. Pull to the second position to adjust steering wheel height. Releasing the lever clamps the column securely at the position selected.

Left Switch Stalk

The left stalk controls turn signals, high / low beam, intermittent windshield wipers and washers, and also contains the hazard flasher control. Turn signals operate in the normal way, push lever forward for right turn and rearward for left turn. Pull stalk up for high beam and/or low beam. Turn knob on end of stalk for intermittent windshield wiper control. Press knob on end for wash cycle. Hazard flasher is initiated by pulling the chrome lever at the base of the stalk. Cancel the flasher by using a turn signal or pressing the hazard lever in.

Right Switch Stalk

The right stalk contains the cruise controls.

Cruise Control

The Cruise Control is provided to improve fuel economy and lessen driver fatigue during long periods of uniform speed travel. To operate the Cruise Control:

1. Attain the desired speed in the normal manner, with the foot-operated accelerator.
2. Press the "On-Off" slider switch toward the left (On) to activate the system at the current speed.
3. Press the button on the end of the stalk to incrementally adjust speed. To make larger speed adjustments, release the cruise control by tapping the brake, and then use the throttle to reach the desired speed. Then again press the slider toward the left.
4. To momentarily deactivate the cruise feature, press the brake pedal. This will disengage the cruise control and begin to apply brakes.
5. When you wish to again use the cruise control feature, press the slider switch toward the left to Resume the previously set cruise speed.

If the ignition is switched off, or if the Cruise Control slider switch is pressed toward the right (Off), the cruise control is deactivated.



Intermittent Windshield Wipe / Wash
Turn for Wipe. Press for wash



Left Switch Stalk

Turn Signals
High / Low Beam
Wipe / Wash

Hazard Flasher Control



Right Switch Stalk

Cruise Control Set
Resume, Accelerate, On / Off



Steering Column Positioning



Tilt / Telescopic Release

Mirrors And Adjustment

WARNING The vehicle's mirror system has been designed to comply with all field-of-view requirements, but it is the operator's responsibility to adjust the mirrors properly before placing the vehicle in service and to maintain the adjustment during the service life of the vehicle. Mirrors provide additional driver visibility on buses. To be used effectively, mirrors must be properly adjusted for each driver, and the driver must be aware of the limitations on viewing area that exist even when mirrors are properly used. Mirrors are not a substitute for proper driver training and care that should be exercised when operating the vehicle and loading or unloading passengers. Do not move the bus until you have accounted for each passenger that has disembarked and have confirmed that all passengers are clear of the bus. Failure to follow these procedures could cause serious injury or death.

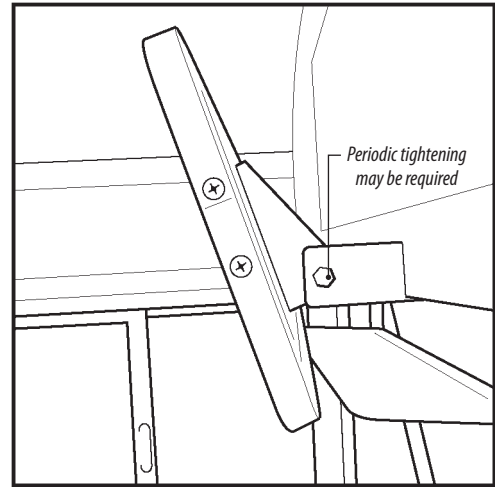

Interior Mirror

Interior Mirrors

Inside rearview mirrors can be adjusted by loosening the bolts and nuts in the slotted holes on the mirror brackets. Because this is a friction mount, periodic tightening of these bolts and nuts may be required. Adjust the mirror to give the operator a clear view of the bus interior and the roadway to the rear.

WARNING After unloading passengers, do not move the bus until you have confirmed the location of each disembarked passenger, and you are confident all of them are clear of the bus.

Exterior Rearview

Standard equipment on all school buses includes four outside rearview driving mirrors (two per side), and two elliptical cross view mirrors (one per side). The outside rearview driving mirrors include one flat and one convex on each side. The outside rearview driving mirrors are designed to provide the seated driver a view of the roadway to the rear and to the sides of the bus. The elliptical cross view mirrors are designed to allow a seated driver to view all areas around the front of the bus not directly visible. The elliptical cross view mirrors are designed to be used to view pedestrians while the bus is stopped.

WARNING Do not use the elliptical cross view mirrors to observe traffic while the bus is moving.

CAUTION A convex mirror is designed to provide a wide view with minimum distortion. However, persons or objects seen in a convex mirror will appear farther away than when seen in a flat mirror or viewed directly. Use care judging the size or distance of objects seen in a convex mirror.



Curbside Mirror



Driver Side Mirror



Proper adjustment is necessary for any mirror system to perform as designed. The following adjustment sequence should be used to allow the driver maximum viewing area with the mirror system.

1. Adjust the driver's seat to the desired position.
2. Adjust the right-side, flat, driving mirror so that the tops of the side windows are visible in the upper edge of the mirror, and the right side of the bus body is visible in the inside edge of the mirror.
3. Adjust the right-side, convex, driving mirror so that the view in the top of the mirror overlaps the view provided by the right-side flat driving mirror, and the right side of the bus body is visible in the inside edge of the right-side convex mirror.
4. Adjust the left-side, flat, driving mirror and the left-side, convex, driving mirrors using the same procedures described for the right-side mirrors. Refer to Steps 2 and 3 above.
5. Adjust the elliptical cross view mirrors by positioning each mirror head so that the center of its field of view is aimed at the eyes of the driver.
6. Make a final adjustment to the mirror system so that the seated driver can view the areas required by Federal Motor Vehicle Safety Standard 111 — including the entire top surface of cylinders M and N when located as illustrated, and rearward a minimum of 200 feet (measured from the mirror surface) — using the outside rearview driving mirrors. The elliptical cross view mirrors should be adjusted to provide the seated driver a view of the entire surface of any cylinder A thru P (when located as illustrated) not visible by direct view of the driver. The view provided by the elliptical cross view mirrors must overlap the view provided by the outside rearview driving mirror system.

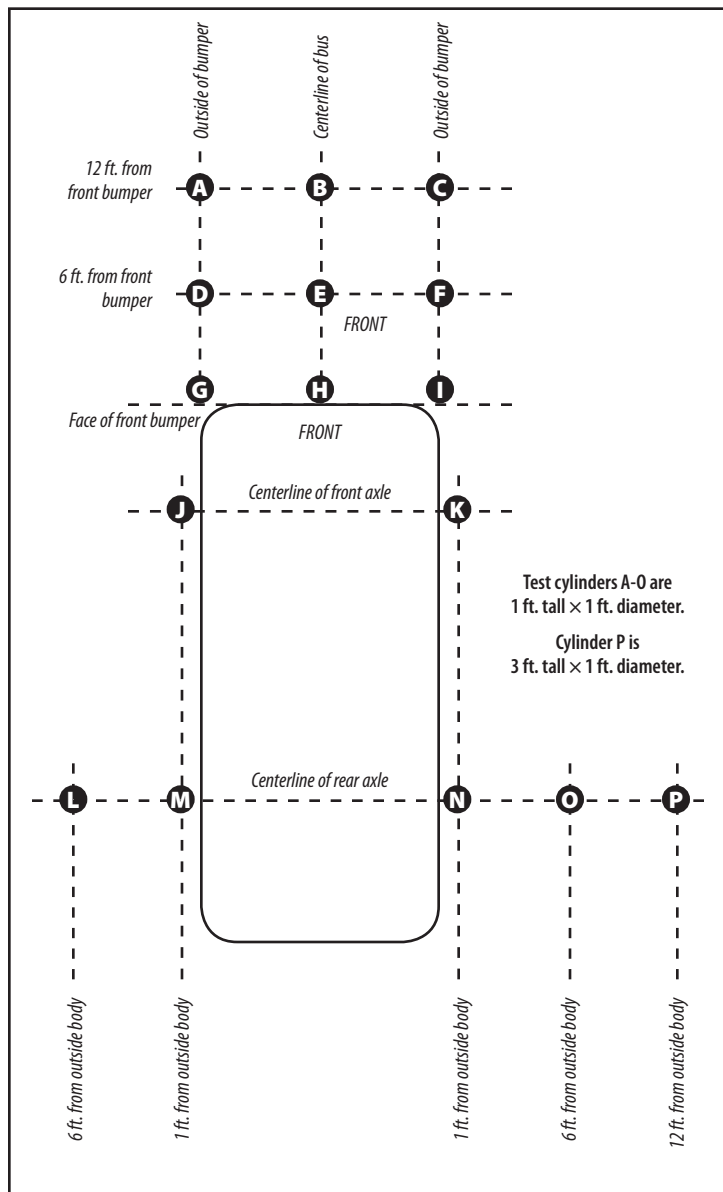

All mirrors should be cleaned once a week (or more if needed), preferably with an ammonia solution. Keep the mounting fasteners tight so that mirrors will not vibrate. Check weekly and tighten, if necessary.

SEATING

Standard Driver's Seat

To adjust seat position forward or backward, hold lever (A) to the left. Shift the seat forward or rearward to the desired position and release the lever.

A hand operated lever (B) on the right side of the seat allows adjustment of the height of the seat. To raise the seat, crouch in the sitting position but do not apply your weight to the seat. Slide the lever toward the rear. This allows the seat base to raise to the desired position. When in the desired position release the slide handle. To lower the seat apply your weight to the seat while holding the slide handle to the rear. This allows you to leverage your weight to lower the seat. Release the slide handle when seat is in the desired position.

To adjust the back angle, lean forward slightly to remove pressure from seat back and turn adjustment knob at left side of seat cushion. For lumbar support adjust knob at right side of seat back.

Premium Driver's Seat

1. Weight and Height Adjustment—to adjust, push in valve knob to raise seat and pull out to lower. When adjusted properly, the seat will not rest against the top, or bottom, limits of vertical motion under normal driving conditions. Adjustment position should also provide for driving visibility and vehicle control.
2. Fore and Aft Adjustment—Hold lever to the left to adjust seat position forward or backward.
3. Back Angle Adjustment—Lean forward slightly to remove pressure from seat back. Hold handle rearward to adjust to any position within range.
4. Cushion Tilt Adjustment—Rotate seat tilt knob to decrease or to increase seat tilt.
5. Lumbar Adjustment—Rotate knob forward to increase, or rearward to decrease, the support in the lumbar area.



Deluxe Driver's Seat Controls



WARNING Do not attempt to adjust the driver's seat, while the vehicle is in motion. Do not adjust height while sitting in the driver's seat. Keep feet and other items away from height adjustment handles and pedals while vehicle is in motion.

Driver's Seat Belt With Shoulder Harness

The driver's seat belt should be worn at all times when the vehicle is being driven. The driver's shoulder harness locks during emergency stops; the lap belt may be either emergency locking or automatic locking, depending on the option chosen. The emergency locking retractor used for all shoulder harnesses and specified lap belts is dual sensitive. The emergency locking retractor engages when the vehicle tips 15° or if belt payout speed exceeds a preset rate. Automatic locking retractors for specified lap belts are self adjusting. Adjust the shoulder belt bracket for driver comfort.

To use, withdraw an adequate length of belt from the retractor or retractors to allow the buckle. After engaging the buckle halves, let the retractor withdraw the belt to a snug fit. The buckle can be released by pushing the button in its center.

Passenger Seat Belts (Optional)

Individual lap belts for passengers are retractable or non-retractable depending on option ordered. Insert the catch into the buckle, test for positive latch, and pull the loose end of strap until the belt fits snugly across the lower hips. The buckle can be released by pushing the button in its center. The adjustable end can be moved outward on its strap by turning 90° to the strap and pulling.

WARNING Be sure the lap belt is fitted snugly around the hips, not the waist. Failure to do so may increase the chance of injury in the event of a collision. Do not bleach or dye the webbing, because such processing may severely weaken the assembly.



Adjusting Seatbelt Shoulder Harness

Child Restraint Seats

Young Children And Infants

Everyone in a vehicle needs protection. This includes infants and all other children. Neither the distance traveled nor the age and size of the traveler changes the need for everyone to use safety restraints. In fact, the law in every state in the United States and in every Canadian province says children up to a certain age must be restrained while in a vehicle.

Every time infants and young children ride in vehicles, they should have the protection provided by the appropriate restraint. Restraints must meet all applicable federal motor vehicle safety standards.

WARNING *People should never hold a baby or young child in their arms while riding in a vehicle. During a crash a baby will become too heavy to hold. For example, in a crash at only 25 mph, a 12 lb. baby will suddenly become a 240 lb. force on a person's arms. A baby should always be secured in an infant restraint. Young children must be secured in appropriate child restraints.*

How Child Restraints Work

A child restraint system is any device designed for use in a motor vehicle to restrain, seat, or position children. A built-in child restraint system is a permanent part of the vehicle. An add-on child restraint system is a portable one that must be installed.

For years, add-on child restraints have used the adult belt system in the vehicle. To help reduce the chance for injury, the child must be secured within the restraint. The vehicle's belt system secures the add-on child restraint, and the add-on child restraint's harness system holds the child in place within the restraint.

When securing an add-on child restraint, refer to the instructions that come with the restraint. These instructions may be labeled on the restraint itself or in a booklet, or both.

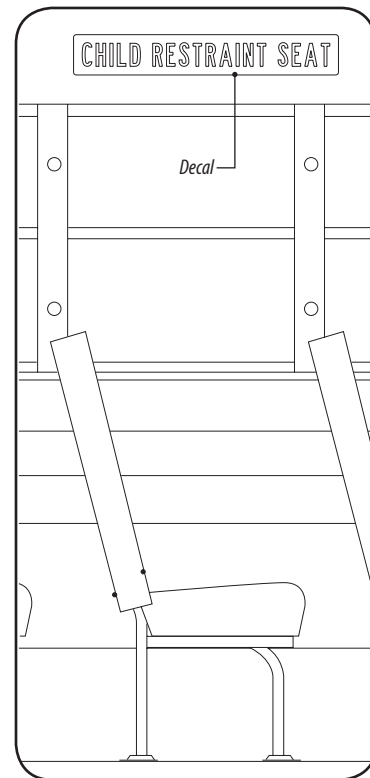



Universal Child Restraint Anchorage

Seats in this bus equipped with the universal child restraint anchors are identified by a decal located over the seat above the window. (See Decal illustration on the following page.)

This vehicle may be equipped with a universal child restraint anchorage system. If so, you'll find two anchors in the front lower seatback where the bottom of the seatback meets the back of the seat cushion and a third anchor in the lower rear seatback. (See the Universal Child Restraint Anchorage illustration.)

In order to use this system, you need either a forward-facing child restraint that has attaching points (A) at its base and a top tether anchor (B), or a rear-facing child restraint that has attaching points (A) as shown.

Whenever applicable, use the universal child restraint anchorage system instead of the vehicle's safety belts to secure a child restraint.

WARNING *If a child restraint isn't attached to its anchorage points, the restraint won't be able to protect a child sitting there. In a crash, the child could be seriously injured or killed. Make sure that the child restraint is properly installed using the anchorage points.*

Securing A Universal Child Restraint

1. Find the anchors (A) for the seating position you wish to use, where the bottom of the seatback meets the back of the seat cushion. See Universal Child Restraint Anchorage illustration.
2. Put the child restraint on the seat.
3. Attach the anchor points on the child restraint to the anchors in the bus seat. The child restraint instructions will show you how.
4. Attach the top strap to the top strap anchor (B). Tighten the top strap according to the child restraint instructions.
5. Push and pull the child restraint in different directions to ensure it is secure.

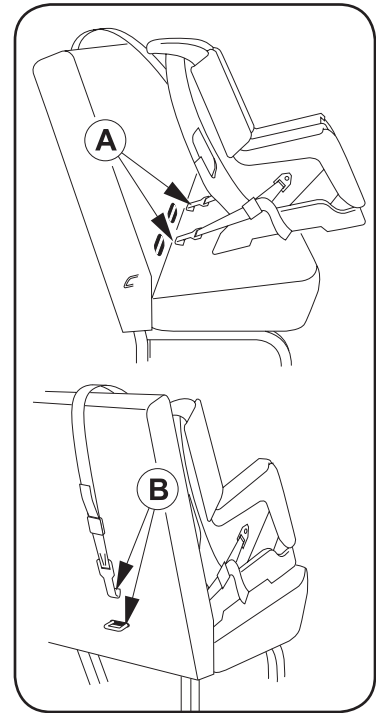

Universal Child Restraint Anchorage

COMPARTMENTS & ACCESS PANELS

All American Front Access

Release the latches on the center panel, allowing it to pivot downward and open. This will allow access to the heater bleeder valve, radiator, radiator fill cap, and the intake air restriction indicator.

Release press button latches on the driver's side front access panel to gain access to the windshield wiper motor, windshield wash reservoir, power steering fluid reservoir, and the brake fluid reservoir. Air tank bleeder valves and the schrader valve for units equipped with air brakes can also be accessed.

The curbside panel can be opened to gain access to the windshield wiper motor, exterior heater filter, and the engine block heater connection.



Press Button Latches



Press Button Latches (Both Sides)

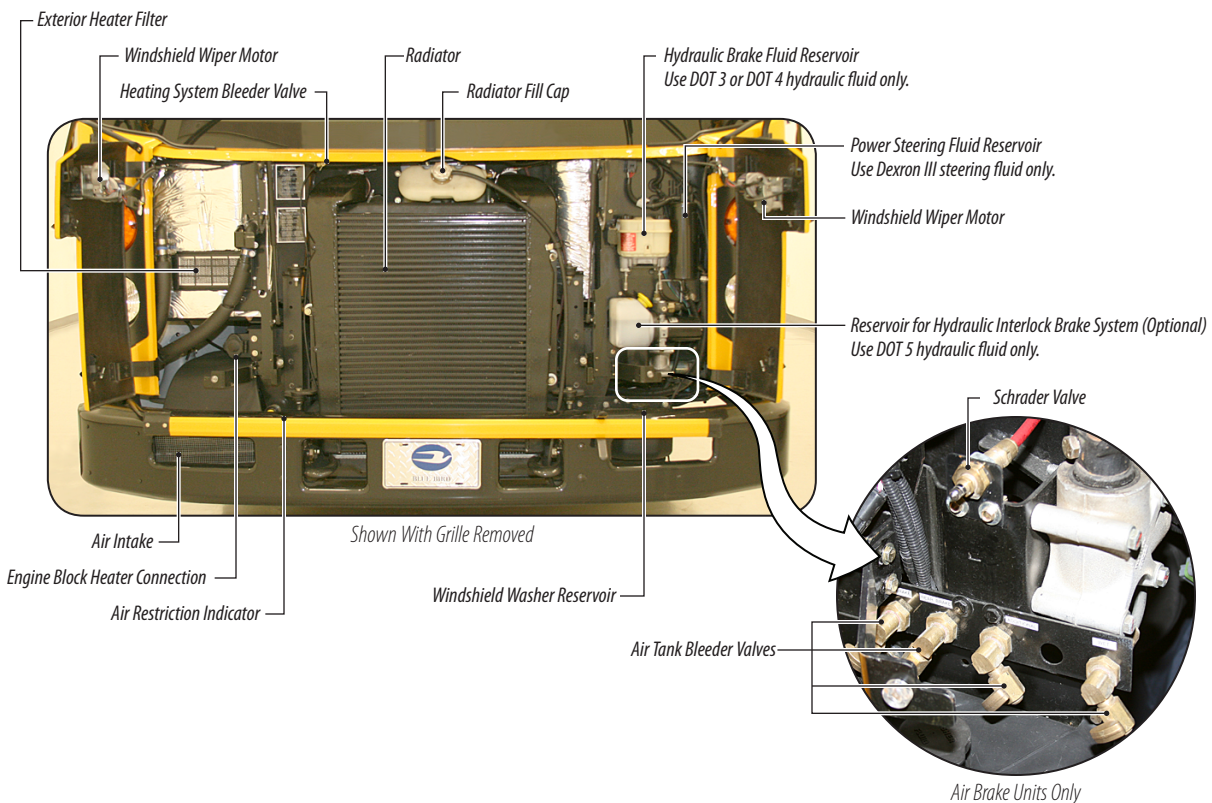

Air Brake Units Only



Engine Access

To open the hood, disengage the latch mechanisms located in two places on the engine cover. Lift the access cover and allow it to rest fully open on the forward portion of the hood assembly. This will allow access to engine components, such as the oil dipstick, engine oil fill, transmission fluid dipstick, etc.

To remove engine cover assembly for better access to the engine components, first remove the cup holder and PA mic. Release one latch at the front corner of the hood located at the floor on the stepwell side. Open the hood and locate four latches on the inner wall perimeter of the hood assembly. One is located on the driver's side toward the front, one is at the rear center and one is located on each side. Releasing these latches will then allow entire hood assembly to be removed for mechanics access.

CAUTION Engine and components can be very hot. If the engine has been running, be careful to avoid burns during engine access and removal process.

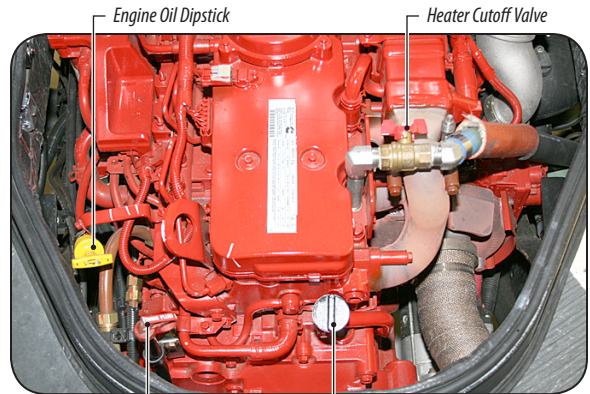

Transmission Fluid Dipstick
Use Transynd transmission fluid only.

Open Hood

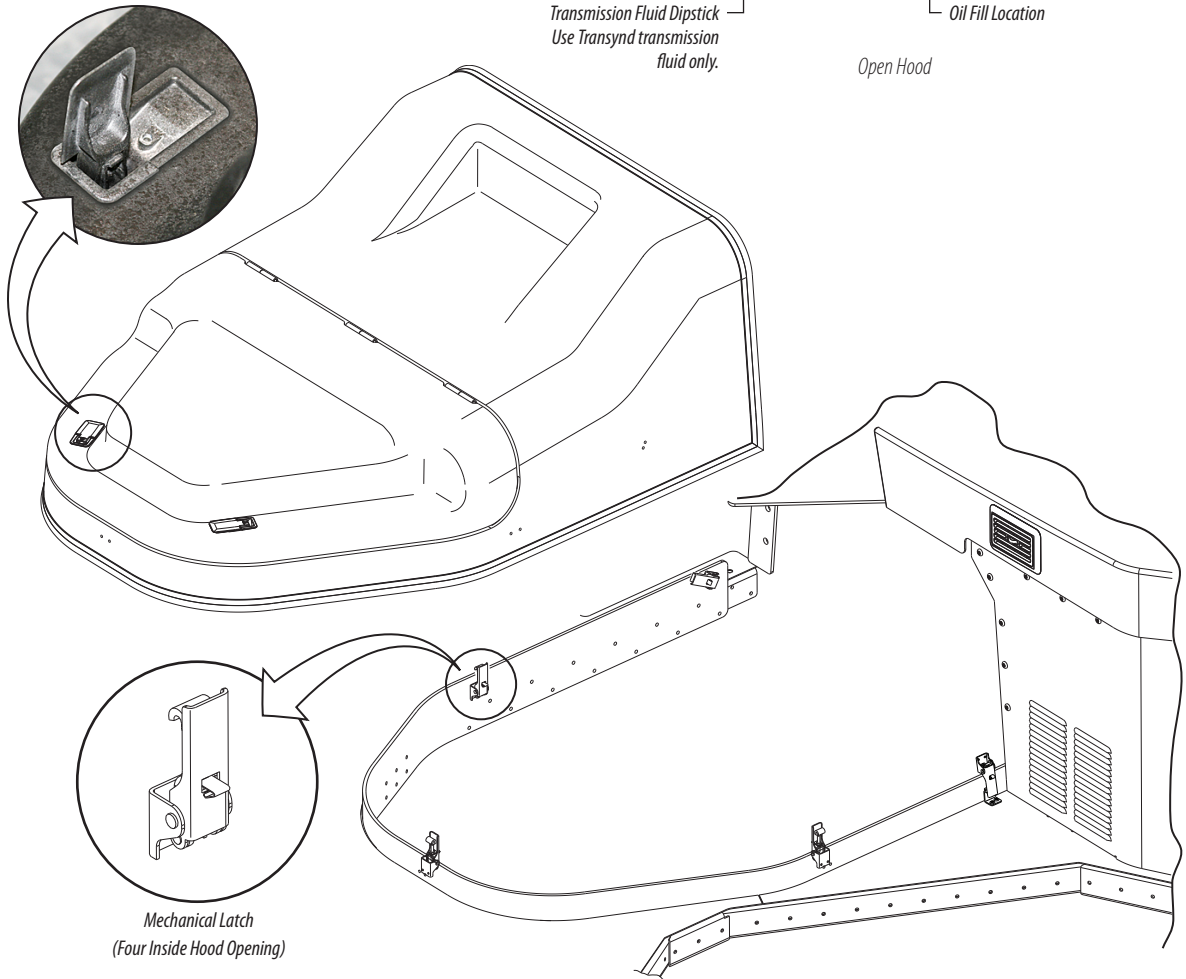

Additional Access Panels

Other access panels include the electrical access panel, PDU (Power Distribution Unit) access panel, fuel fill, and battery compartment.

The electrical panel access door is located on the outside of the bus below the driver's window. Behind this panel you will find circuit breakers and fuses to the bus *body* electrical circuits. Directly below the electrical panel access is the power distribution unit, accessed from a separate panel. This unit contains circuit breakers and fuses for *chassis* electrical circuits. This unit also has a separate cover with spring latches to help protect the circuits from the elements.

Located behind the front axle on the driver's side is the battery compartment. The latch on this compartment panel is different from the push button type latches on the previous panels. To open, pull the latch handle.

Optional key locks are available on all panel latches.

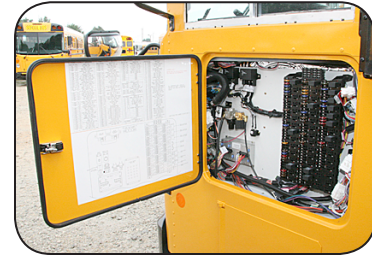

Body Electrical Panel Access



Chassis PDU Access

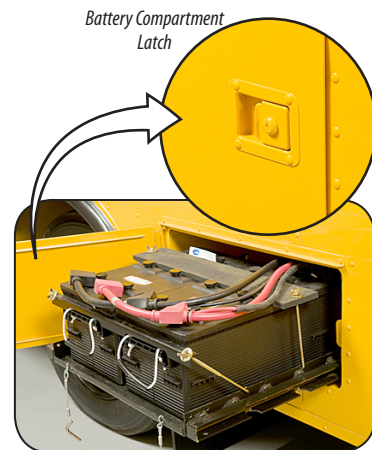

Battery Compartment



Passenger safety is the bus driver's first priority. In the event of enroute emergency or roadside hazard, the driver must be confidently familiar with the location and use of safety devices, emergency equipment and roadside procedures in order to maintain order, guide passengers to safety, and properly position and secure the bus until assistance arrives.

EMERGENCY EXITS

Emergency exits are clearly identified by the words “EMERGENCY EXIT.” Operating instructions are printed near each exit. Some units are equipped with an audible alarm which sounds if an emergency exit is unlatched or open. If a buzzer sounds when turning on the ignition switch, check emergency exits to see that they are closed. All emergency exits meet Federal Motor Vehicle Safety Standard 217, “Bus Window Retention and Release.” These illustrations show various types of emergency exits.

WARNING All emergency exits should be checked daily to ensure they are clearly labeled and operate properly. Exit windows, doors and hatches must not stick or bind, and must open smoothly and reliably without undue force. Report any damage or defects immediately and repair before transporting passengers.

Rear Emergency Door

The rear emergency door is opened by lifting the long horizontal handle all the way upward and pushing the door outward. The door is equipped with a hold-open telescoping strut at the top of the opening. When the door is fully opened, a pawl in this strut rotates to prevent the door from falling shut. To close the door, push it outward to the end of the strut’s travel. This causes the pawl to rotate again, allowing the door to close. Close the door smoothly, push it against the frame firmly to compress its seal, and close the handle latch fully.

Rear Emergency Door hold-open strut

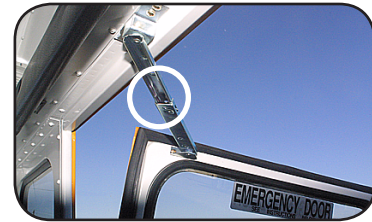

Transpec™ Safety Vent

The roof hatch serves as an important emergency exit. It is important that it is maintained properly and instruction labels are in place and clearly visible. All emergency exits should be inspected and operated daily to ensure that they are labeled and operate according to the instructions provided.

Maintenance Cautions

Transpec™ Safety Vents are designed to provide years of reliable service with a minimum amount of maintenance. All components are rustproof with lifetime finishes, and moving parts are Teflon™ coated to eliminate need for lubrication. Use of lubricants, paints, or other coatings—such as graffiti-detering spray—is not recommended.

Suggested maintenance includes periodic inspection of attaching fasteners for evidence of loosening due to tampering, and regular cleaning with mild soap and water. Although there are more powerful cleaning solutions available, some of them contain solvents and other chemicals that can attack the high strength materials used in the production of safety vents. It is the customer’s responsibility to ensure that cleaning solutions are compatible with the materials used on safety vents.

Graffiti-removing cleaners often contain acetone, ether, lacquer thinner or other solvents known to destroy the high strength properties of many engineering plastics, and use of these cleaners must be avoided. Graffiti-resisting coatings often leave a sticky residue that interferes with the operation of the ventilator mechanism. Use of these types of chemicals should be avoided.

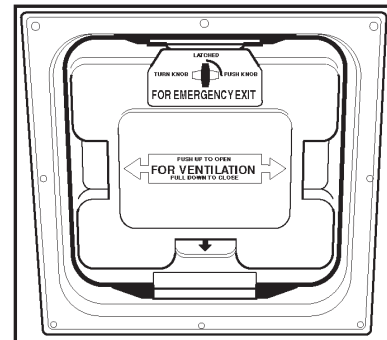

Roof Hatch

Pop up (front or rear) or raise for additional ventilation



Split Sash Pushout Window

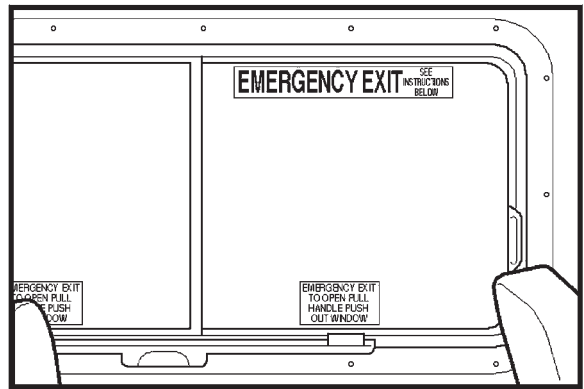

Transit Sliding Pushout Window



Side Emergency Door



Rear Emergency Door

EMERGENCY EQUIPMENT

Each state or province has unique laws regarding emergency equipment. Your unit may have some or all of the items listed below. Because of variations in option packages, the placement of this equipment inside the bus may vary from one unit to another, but it is important for you to recognize and know the locations of all the emergency equipment on your bus. It is important that you read, and understand all literature, labels, and other written materials supplied by the equipment manufacturers. Be sure you familiarize yourself with all aspects of the emergency equipment before attempting to drive the bus.

Fire Extinguisher

The fire extinguisher is normally located to the left of the entrance door, or in a compartment over the interior rearview mirror, or on the right-hand side of the hood ledge near the stepwell when space is available. Your unit may be equipped with a 2.75, 4.5, 5, or 6 pound extinguisher, depending on the laws of your state or province. Inspect the pressure gauge every 30 days, or as required by individual state fire laws, to be certain the unit is fully charged. Inspect mounting fasteners periodically to be sure they are secure.

First Aid Kit

The first aid kit is mounted in the front of the bus body just above the right windshield. Size and contents of first aid kits vary due to state specifications. The contents of the kit should be inspected weekly or as required by local regulation to ensure that all contents comply with state specifications.

Body Fluid Cleanup Kit

The body fluid cleanup kit is designed to contain accidental spillage of biological matter, minimizing risk of exposure to potential health hazards. The contents of the kit should be inspected monthly, or as required by local regulation, to ensure that all contents comply with state specifications.

Fire Axe/Crowbar

The fire axe and crowbar are located on the electrical panel access cover to the left of the driver's seat as near to the front as possible. Every 30 days, inspect installation mounting fasteners to ensure that they are secure. Check fire axe and crowbar monthly to ensure that they are easily accessible and unobstructed.

Flare Kit

The flare kit is mounted on the left-hand side panel behind the driver's seat. Every 30 days or as required by local regulations, ensure that the contents of the flare kit are in place. Inspect mounting fasteners for flare kit box every 30 days to make sure they are tight.



Triangular Warning Devices

For states requiring the triangular warning devices be located in the driver's compartment, this container is mounted above the windshield at the upper center near the roof line. For other states, it is located on the left-hand rear floorboard, under the rear seat. Inspect contents of the kit every 30 days or as required by local code to ensure proper operation.

Recommended Warning Device Positioning

Some states allow a lockable "Emergency Equipment" compartment. This optional compartment is located above the windshield, toward the center of the bus. Supplies are organized and labeled in the compartment. The compartment locking mechanism is fitted with a warning buzzer, which will sound if the compartment is locked while the ignition switch is in the "on" position.

On rear engine units, the emergency equipment is located in the front of the bus. The compartment is located at the centerline of the bus at floor level, depending on the options selected at the time of manufacture.

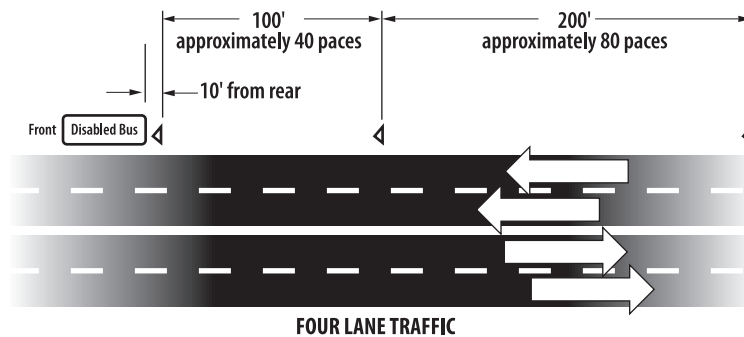
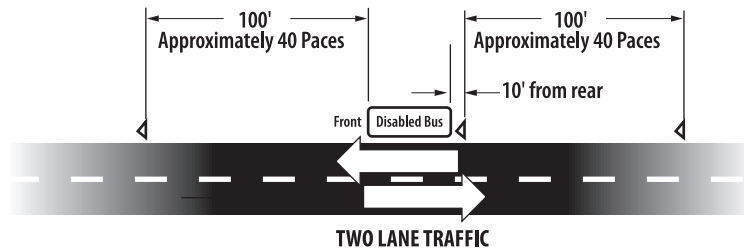

TIRE / WHEEL EMERGENCIES

Spare Tire Location And Removal

If your unit is equipped with a frame mounted spare tire carrier, located in the rear overhang, follow this procedure to remove and replace spare:

1. Remove the two securing nuts at the tire mounting plate of the carrier.
2. Insert the handle through the access hole in the outside skirt panel and into the slotted receptacle of the tire carrier shaft.
3. Slowly lower the tire by turning counter clockwise.

WARNING *Hold the handle securely while lowering the tire.*

4. Remove the lifting platform from the tire.
5. To reinstall the tire, reverse these procedures, making certain to tighten the securing nuts at the mounting plate.

WARNING *Never move under a vehicle supported only by hydraulic jacks. Always chock the wheels that are not being raised in both directions. Do not get under the tire/wheel while replacing a flat.*



Damaged Tires

WARNING An inflated tire and rim can be very dangerous when misused or worn out. Many accidents, some fatal, have resulted from improper handling and operation of bus rims and wheels. To help avoid personal injury and/or property damage, get expert tire service help if you can. If you must remove the wheel and change the tire without such help, take the following precautions:

- If the tire seems to contain air under pressure, stand to the side and check whether the wheel assembly appears normal by comparing it to another wheel assembly on the vehicle.
- Let the air out of the tire by taking out the valve core. If you have a way to put air back into a tire, note that it is good safety practice to let the air out of both tires of a dual assembly before taking off the damaged tire and rim assembly from the vehicle. After letting out the air, take off the tire and rim assembly and put on the spare wheel and tire assembly.
- If you are not fully expert on the procedures to follow, and/or are not equipped with the proper tools and equipment, do not attempt to raise the vehicle or remove or install the tire and wheel assembly. Obtain expert tire service help.
- Do not inflate a tire that has been run flat or is seriously low on air without first having the tire taken off the wheel and the tire and tube checked for damage.
- Note that work on bus wheels requires proper tools, safety equipment, and special training. You can be badly injured and/or damage can result from using the wrong service methods. Only trained people using the proper equipment should service bus tires and wheels.
- When putting air into a tire on the vehicle, stand to the side and use a clip on chuck and hose extension. Never add to your tires unless an accurate pressure gauge is also used. In choosing the right tire pressure, be careful not to go past the maximum pressure capacity shown on the tire.

WARNING Tire inflation pressure must not exceed the specifications of the tire and/or wheel rim manufacturer for the specific load, speed, and application. The inflation pressure embossed on the tire sidewall does not take the wheel or rim capacities into consideration. Tires should not be inflated above the pressure listed on the label without consulting your tire/wheel distributor.

Wheel And Rim Safety

Wheels and wheel components must be properly maintained to avoid adverse effects on the life of the tire and/or wheel. An inflated tire is potentially very destructive. Careless handling and inexperience cause accidents. Safety literature can be obtained from your wheel and rim distributor, a wheel and rim manufacturer, NHTSA, or OSHA. If you have any questions, consult the distributor or manufacturer directly. The load carrying requirements of each vehicle should also be determined before selecting the proper tire/wheel combination. Always remember that the weakest weight carrying component of the vehicle (i.e., the tires, wheels, axles, bearings, etc.) determines the load carrying capacity for the vehicle.

WARNING *Improper handling of wheels and rims has caused many injuries and deaths. Failure to follow directions is the leading cause of such accidents. Obtain procedures from wheel and rim manufacturer before working with a wheel or rim.*

The tire and wheel must always be properly matched. For example, do not mount a 20-inch tire on a 22-1/2-inch wheel. Failure to strictly adhere to these important instructions may result in an explosive separation and could cause serious bodily injury or death. It is very important to determine the size of each component before beginning any assembly operations.

When replacing tires, use the same size, load range, and construction type as originally installed on the vehicle. When replacing wheels, use original equipment manufacturer's wheels or equivalent available from your dealer with equivalent capacity, width, offset, and mounting configuration as those originally installed on your vehicle. Use of improper replacement wheels and tires may adversely affect ride, handling, load carrying capacity, bearing life, the clearance to body and chassis components, vehicle ground clearance, vehicle width, and brake cooling. Do not mix rim, lock ring, and wheel components from different manufacturers.



Jacking Instructions

WARNING Proper jacking procedures and basic safety measures must be observed to ensure safety of personnel while working under the bus. Always check the serviceability of any lifting equipment prior to use. Ensure that the lifting device is of sufficient strength to handle the bus, and that the surface provides the necessary firmness to support the weight of the bus concentrated on the footprint of the jack. Never move under a bus supported only by a hydraulic jack.

1. Park the bus on flat, level concrete or a comparable surface, capable of supporting the jacking device.
2. Apply the parking brakes.

WARNING The parking brake functionality relies on the rear wheels remaining in contact with the surface the bus is parked on. If one or both wheels are lifted off the surface the park brake will not function and the bus may move resulting in potential bodily harm or death.

3. Place chocks at the front and rear of the tires opposite the wheel, or wheels, to be lifted first.
4. Use jacks and jack stands, or blocks of sufficient capacity, to support the vehicle. Following the jack manufacturer's recommended procedure, place the jack securely under the axle at a spring or suspension beam nearest the tire/wheel to be repaired.
5. Jack the bus only to the height necessary to service.

WARNING Ensure any locking device on the jack is in place and operating properly. Support the vehicle under the main frame rails with jack stands or blocks before working under or around the bus.

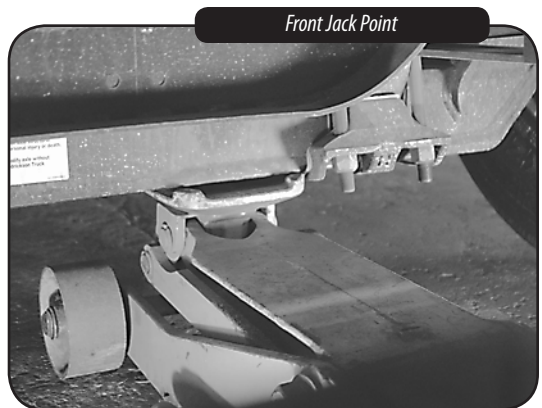
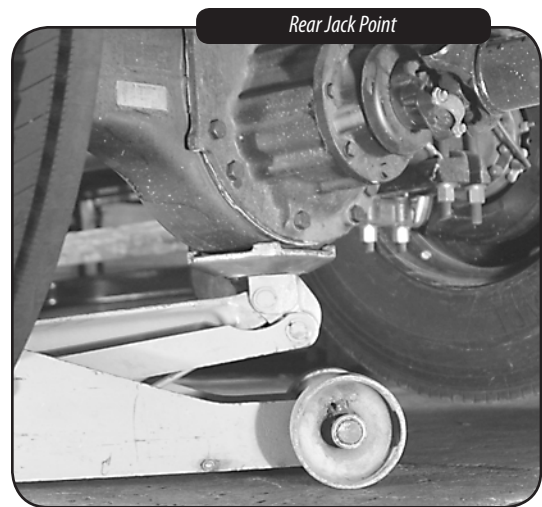

6. After servicing is complete, lift the bus just enough to remove the jack stands or blocks.
7. Carefully lower the bus.

WARNING Do not work under a bus supported by jacks. Use only appropriate lifts and/or jack stands supporting frame rails when working under bus.

Changing a Flat Tire

The lug nuts are tightened to a torque value of 450 - 500 Ft lb (610 – 678 Nm). Without the proper power tools, it is very difficult to remove the lug nuts. The lug nuts must be “broken loose” before lifting the wheel off the ground.

WARNING Never work around or under a bus supported only with a hydraulic jack.

1. Remove the lug nuts.
2. Position the spare as near to the hub as possible.
3. You will probably need to raise the hub slightly to position the wheel on the studs (lugs).
4. Hand-tighten all lug nuts.
5. Using the lug wrench, tighten all the lugs about a quarter turn.
6. Remove the blocks or jack stand.
7. Lower the bus enough to lock the wheel in place.
8. Tighten the lug nuts to 50 ft lbs (68 Nm) in the sequence shown.
9. Check the wheel for proper positioning on pilots and proper seating against the flange.
10. Tighten the nuts to 450–500 ft lbs (610 – 678 Nm) in the sequence shown.
11. Lower the jack and remove it from under the axle. Stow the damaged wheel and tire assembly, and the tools.

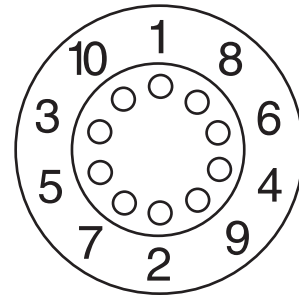



Schrader Valve

All American buses equipped with air brakes have a Schrader valve which is located at the front behind the driver's side access panel. It allows the air brake reservoir to be charged with a common type air hose normally used by service stations and garages. Charging the system in this manner is only a means of providing air pressure for the air brake system with an inoperable air compressor or without cranking the engine and should only be used for moving the bus while servicing or in case of emergency. Air tank bleeder valves are also provided in this location. The valves are used for bleeding the air tanks of moisture and contamination.

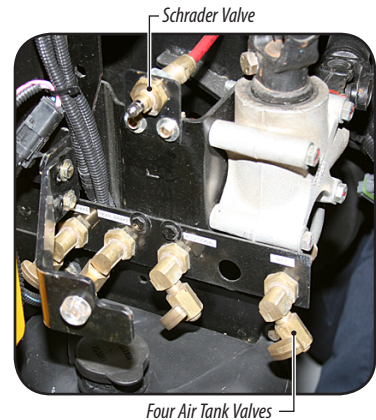

Releasing Spring Brake Manually

When air pressure fails in the rear service brake chamber, the power spring applies the rear service brakes. Unless pressure can be re-established, the service brakes must be released, as follows, to move the bus.

WARNING Do not release the spring brake until the bus is secured by wheel chocks or tow vehicle. Failure to do so may result in bodily injury or property damage.

1. Remove the release stud tool and nut from the carrying pocket on the brake chamber assembly.
2. Remove the access plug from the end of the spring chamber.
3. Insert the release stud through the opening in the chamber and into the spring pressure plate.
4. Turn the release stud one quarter turn to engage the stud tangs with the slot in the pressure plate.
5. Keep the stud engaged and install the nut on the release stud.
6. Tighten the nut until the spring is fully caged and the brakes are released.
7. Do not loosen or remove the release stud and nut unless the brake chamber is completely assembled and is securely clamped.
8. When air pressure is restored, remove the release stud and install in carrying pocket.

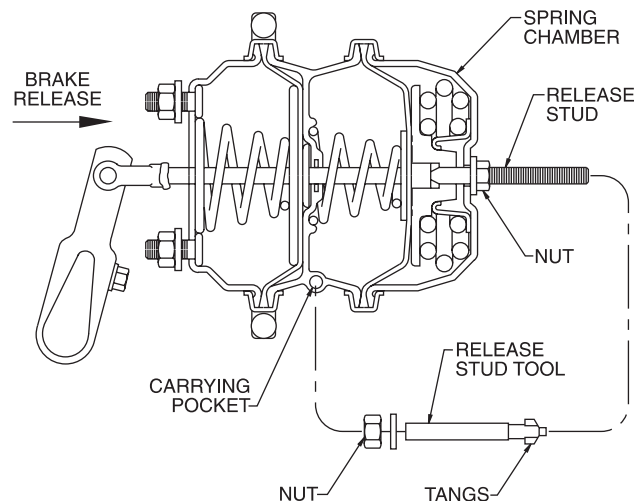

Towing Or Pushing

Tow hooks are provided as optional equipment. They are frame and brace mounted at the front and rear of the bus.

CAUTION *Never tow or push a vehicle equipped with an Allison automatic transmission unless the drive shaft has been removed, or the rear wheels have been raised off the ground. Do not tow by the front axle or any frame cross-member. Damage to the wiring and/or the air lines can result. Optional tow hooks are located at the front and/or rear of the vehicle under the bumper. Tow hooks and tow eyes are designed to tow or pull with both hooks simultaneously. Do not pull or tow with an individual hook. Bumpers provided on Blue Bird buses are designed to protect the vehicle and occupants from front and rear collisions. They are not designed for towing or jacking up the vehicle. Blue Bird does NOT recommend towing or jacking the vehicle by the bumpers.*

WARNING *Exercise extreme caution when the drive shaft is removed on a unit equipped with hydraulic brakes. The parking brake becomes inoperative when the drive shaft is disconnected. Do not leave the bus unattended until taking appropriate measures to prevent vehicle movement. Do not work under the bus when supported by bumper jacks. Use only appropriate jack stands supporting frame rails when under the bus.*

WARNING *Do not lift the bus with the rear tow hooks or tow eyes. Tow hooks or tow eyes should be used for flat ground maneuvering only.*





Although the controls of a modern bus may appear similar to those of a regular passenger car or truck, the size and weight of the bus and its payload require many differences in design, components, and operating procedures. This section describes special considerations in operation of the engine, transmission, brakes, and other systems.

Remember: The bus is eight feet wide without outside mirrors and is 25 to 40 feet long. Therefore, it is two feet wider and two to three times as long as the average automobile. Acceleration will be slower than that of an automobile. The inexperienced operator may find that steering, brakes, and other systems feel different from what is familiar. In addition, the driver/operator must ensure that the loading area around the bus is clear of pedestrians before stopping, and that all unloaded passengers are a safe distance away from the bus before moving. For these reasons it is very important, from a safety standpoint, to become familiar with bus operation through experience before attempting passenger transit.

WARNING *No one should attempt to operate this bus without: (1) thorough knowledge of all instruments and controls, (2) supervision, or actual driving experience in this or a similar vehicle under supervision, and (3) the appropriate license or permit to operate. Do not drive the bus until the space in front, on the sides, and in the rear is unobstructed. Most accidents occur because the operator did not ensure a clear path before driving.*

Inspection guidelines from individual state inspection manuals (such as Commercial Driver's License pre-trip inspection procedures) take precedence over those found in this manual. Guidelines found herein are in addition to those in your state's inspection requirements.

PRE-ROUTE INSPECTION

To keep your bus in the best operating condition, any malfunction or defect should be corrected before the next trip. Report needed services to responsible maintenance personnel.

Engine/Transmission:

- Check fuel level.
- Drain air tanks.
- Drain fuel/water separator.
- Check engine oil level.
- Check automatic transmission fluid level.
- Inspect engine air intake system, especially the air cleaner service indicator. See Air Intake System Inspection in the General Maintenance section of this manual.
- Inspect the engine coolant level at the sight glass.
- Remove any foreign material and dirt from the outside of the radiator core.

Body, outside the bus:

- Clean the windshield, mirrors, front windows, headlights, taillights, directional lights, and brake lights.
- Is the tailpipe clear?
- Does the rear emergency door open and close? Check warning buzzer operation.
- Check the wheelchair lift operation, if so equipped.
- Check tire pressure and the treads. Are the lug nuts in place?
- Drain the air brake tank.
- Is the area under the bus all clear?
- How is the general outside appearance? Is it clean? Is there a clear view of identifying features (license plate, school name, bus number, etc.)?
- Are the mirrors clean and adjusted?

Body, inside the bus:

- Are the seats and floor clean? Are the steps and aisle clear?
- Verify that all emergency exits open and close properly, and do not stick.
- Check the emergency equipment and the first aid kit.
- Is the fire extinguisher in place?
- Are the windshield and windows around the driver's area clean?
- Are the mirrors clean and adjusted?
- Are emergency doors/windows unlocked and operating freely?
- Do buzzers activate when exits are not fully latched?
- If so equipped, does the wheelchair chime sound?

**Starting the engine:**

- Be sure parking brakes are on.
- Put the transmission in Neutral.
- With the key in the "ON" position, check the fuel gauge. Check the brake warning buzzer or light, and the neutral safety switch.
- Start the engine. Look and listen for trouble signs; check the gauges.
- Does the wheelchair lift interlock function properly, if so equipped?

With the engine running, check (from driver's seat):

- Mirrors, interior and stepwell lights, service door seal.
- Does the steering feel OK? Is there any unusual noise?
- Check the horn, defroster and heater blower, and windshield wiper operation.
- Does the brake pedal have the right height and feel? Is the gauge reading OK?
- If so equipped, does the wheelchair interlock function properly?

Outside checks required before driving away:

- Check turn signals in front and rear. Are they clean and flashing?
- Are flasher warning lights in front and rear clean and flashing?
- Is stop arm clean and working?
- Check high and low beam headlights.
- Are brake lights and taillights clean and working?
- Is hazard flasher working?

Final check while moving the bus:

- Is seat belt fastened?
- Do brakes stop and hold?
- Does steering feel OK? Are there any unusual noises? Is bus under control and tracking straight?
- Brake to a stop. Are all gauges OK?

Remember: Safety on the road depends on you. Observe weather and road conditions and drive accordingly. Be physically and mentally alert. When backing up near pedestrians or in congested areas, use someone outside to monitor or direct your movements. Look around before driving away from where you are parked and observe all traffic rules and regulations.

Weekly Inspection

- Perform all the Daily Inspection procedures.
- Drain air tanks.
- Check tires. Look for weather checks, worn areas and tread. Check the air pressure.
- Inspect seat cushion attachments for tightness.
- Inspect seat belts and buckles.
- Inspect outside lights for proper operation.

ENGINE OPERATION

Engine Exhaust Caution (Carbon Monoxide)

WARNING *Never idle the engine in a confined area. Never sit in a parked or stopped vehicle with the engine running. Exhaust gases, particularly carbon monoxide, can build up. These gases are harmful and potentially lethal. Carbon monoxide is colorless and odorless, but can be present with all other exhaust fumes. Do not drive with exhaust fumes present.*

If you suspect exhaust fumes are entering the bus, have the system inspected to determine the source, and make the appropriate corrections immediately.

The best protection from carbon monoxide entry into the bus is a properly maintained engine exhaust system, body, and body ventilation system. It is recommended that the exhaust system and body be inspected by a competent mechanic:

- Each time the vehicle is raised for an oil change.
- Whenever a change is noticed in the sound of the exhaust system.
- Whenever the exhaust system under the body or the rear of the vehicle is damaged.
- Whenever there is an inspection of piping and joints. Replace clamps that are leaking.

Exhaust system clamps are not reusable. Seal with exhaust sealant and install new clamp. Do not run the engine in a confined area (such as garages) longer than necessary to move the vehicle in or out of the area. When your bus is stopped in an open area with engine running for more than a short period, and if it is equipped with combination heating and external ventilation, then adjust the heating or ventilation system to force outside air into bus with the blower set at medium or high speed.

Keep the air inlet grille clear of snow or other obstructions at all times to assure proper operation of the ventilation system. Sitting in a parked vehicle with engine running for an extended period, in either a confined or open environment, is dangerous.

Diesel Fuel

All American units should take advantage of the high energy content and generally lower cost of No. 2 diesel fuel. Experience has shown that diesel engines will operate satisfactorily on No. 1 fuel. The engine in this vehicle must be operated only with ultra low sulfur diesel fuel (meeting EPA specifications for highway diesel fuel, including a 15 ppm sulfur cap). Also see, Cummins Bulletin No. 3379001.

WARNING *Use caution when filling the fuel tank(s) with a high delivery nozzle to prevent spillage. Fuel spray can cause serious injury; vent slowly. Do not fill to more than 95% capacity.*

CAUTION *In 2010 emission standard compliant engines, use only diesel fuel labeled Ultra Low Sulfur, per the engine manufacturer's specifications.*

In Cummins, use oils meeting API CJ-4/SL and Cummins Engine Standard CES-20081. See Cummins Owners Manual ISB 6.7L CM2150 for details.



Diesel Engine Starting Procedure

See the appropriate engine manufacturers operating manual for proper starting procedures. Starting procedures vary from different engine manufacturers and also varies with temperature.

1. Apply the parking brake.
2. Place the transmission shift lever in the neutral position.
3. Insert the ignition key and turn it to the ON position. All the instrument panel lights will come on momentarily. Depending upon conditions, the Wait To Start light may remain on. If so, wait until it goes off before trying to start the engine. This gives the engine grid heaters enough time to warm the combustion chambers for efficient starting.
4. After the engine starts, turn on the high idle switch (1,000-1,200 rpm) until the engine is fully warmed up.

CAUTION *Do not engage the starter longer than 30 seconds without allowing the starter 120 seconds rest.*

If the engine fails to start after a reasonable time, determine the cause of the failure. Pumping the accelerator will not assist in starting the engine. Refer to the engine manufacturer's recommended procedures.

CAUTION *Do not race the engine during the "Warmup" period.*

Starting With Boost Cables

WARNING *Batteries can emit corrosive and potentially explosive fumes. Prevent sparks near the batteries. Do not allow battery cable ends to contact each other or the engine. Do not smoke when observing the battery electrolyte levels. Electrolytes are corrosive and can cause personal injury if they contact skin or eyes. Always wear protective glasses when working with batteries.*

The Blue Bird All American bus has a 12-volt starting system. Use only 12 volts for boost starting. The use of a higher voltage will damage the electrical system.

Always connect the boost cables in parallel with the bus battery cables, negative (-) to negative (-) and positive (+) to positive (+). Do not reverse the battery cables. The alternator can be damaged.

Attach the ground cable last and remove it first.

1. Fasten the positive (+) clamp of the boost cable to the positive (+) post of the battery.
2. Fasten the negative (-) clamp of the boost cable to the negative (-) post of the battery.
3. Start the engine.
4. After the engine starts, disconnect the negative (-) boost cable from the battery.
5. Disconnect the positive (+) boost cable from the battery.

Using The Engine As A Brake

While going down a steep or long grade, it is a good practice to use the engine to retard vehicle speed. Reduce speed before the grade and shift into a lower gear (with either automatic or manual transmissions), being careful to select a gear which will slow the vehicle without over speeding the engine. Under such conditions, use the brakes sparingly, to prevent overheating. Overheating will cause the brakes to "fade"; that is, be less effective.

WARNING *Do not take transmission out of gear when the bus is moving.*

You may not be able to get the transmission back in gear, and the drastic slowing of engine speed could reduce air pressure supply to the air brake system, and result in a reduction of brake capacity.

Engine Warning System

Your All American bus may have an optional alarm system to signal low oil pressure and high engine temperature. If the engine temperature exceeds the manufacturer's recommendations, or if the oil pressure drops below the manufacturer's recommendations, a buzzer sounds and an indicator light glows.

CAUTION *If the alarm system sounds, shut the engine off as soon as possible after the bus has been steered to a safe zone. Operation of the engine after the alarm sounds could cause serious engine damage.*



Exhaust System

New federally mandated emission standards affect all buses equipped with 2010 emission compliant diesel engines. Both nitrogen oxides (NOx) and particulate matter are reduced by 90 percent from 2004 levels. The exhaust system of the Cummins engine in Blue Bird buses are *aftertreatment* systems which incorporate a *Diesel Particulate Filter* (DPF) and a Selective Catalytic Reduction (SCR) system instead of ordinary mufflers. These sophisticated exhaust systems reduce emissions by trapping exhaust-borne particulates (soot) in a filter built into the DPF. The SCR system then reduces NOx levels through a chemical reaction changing the NOx into harmless nitrogen and water.

Soot accumulates in the DPF over time and must be removed by a process referred to as *regeneration*. Regeneration is conceptually similar to the cleaning mode of a self-cleaning oven in that heat is required to remove the soot.

The rate at which soot accumulates is dependent upon multiple conditions including the quality of the diesel fuel, type of engine oil, ambient temperature, engine load, and other factors. Regeneration occurs in three ways:

- Some regeneration occurs “naturally” whenever operating conditions (speed, engine load, etc.) result in exhaust system temperatures high enough to oxidize accumulated soot. This unassisted regeneration process can generically be referred to as “passive” regeneration.
- Regeneration can be caused by raising the temperature of the exhaust system. Cummins engines are equipped with systems designed to increase exhaust temperature when the ECM senses that regeneration is needed, and when certain requirements, including a minimum travel speed, are met. This automatic “heat assisted” mode can be generically referred to as “active” regeneration.
- Regeneration can be manually activated by means of a switch. This procedure is generically referred to as “stationary” regeneration, and should only be performed by or under the direction of a qualified service technician, and in a controlled environment to avoid the potential for human injury or fire hazards.

The need for regeneration is communicated to the driver by a set of visual and audible signals in the instrument panel. An additional alert, the High Exhaust System Temperature (HEST) indicator, notifies the driver whenever exhaust system temperature is high due to recent regeneration.

Eventually, the normal ash accumulation which results from the regeneration process must be removed from the DPF, using equipment designed for the purpose at qualified engine service facilities. Refer to the engine manufacturer’s documentation for these service intervals. The engine operator’s manual provided with your bus contains additional information about exhaust system regeneration, and should be read and understood by the driver.

CAUTION *In 2010 diesel engines, use only diesel fuel labeled Ultra Low Sulfur, per the engine manufacturer’s specifications.*

In Cummins, use oils meeting API CJ-4/SL and Cummins Engine Standard CES-20081. See Cummins Owners Manual ISB 6.7L CM2150 for details.

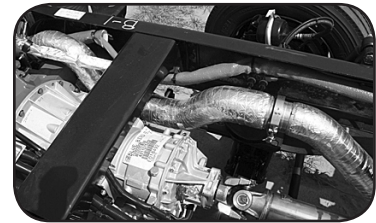

The exhaust systems of 2010 EPA emission compliant diesel engines incorporate engine-specific Diesel Particulate Filters, which operate at higher temperatures during their Regeneration cycles. Due to the hot temperatures generated through the exhaust system, front exhaust pipes, tailpipes, adjacent hoses and tubing are insulated in sensitive areas for protection from the heat on all Blue Bird products.

DPF Regeneration In Blue Bird Buses

As with most new mechanical processes, the introduction of more sophisticated exhaust systems in 2010 emission standards-compliant engines has generated some degree of initial confusion. Engine manufacturers have designed their own methods to accomplish the regeneration (cleaning) of the DPF, and therefore describe the process in somewhat differing terms.

The Cummins equipped Blue Bird bus exhaust system is not complicated. Nor should the regeneration process be regarded with alarm. Both Drivers and service technicians should be at least conceptually familiar with the regeneration process.

As soot builds up in the DPF, the driver is notified in several stages by visual and audible alerts. The alert system is designed to provide reasonable and comfortable fore-warning and adequate opportunity for the needed regeneration. As the need for regeneration becomes more severe, the alerts become increasingly imperative; and the penalty for postponing the needed regeneration also increases.

When the earliest alerts occur, there is typically ample time to complete a route and then have a Stationary Regeneration procedure performed at a proper facility. If early alerts are ignored, and the condition is allowed to worsen, the engine will eventually de-rate automatically, and performance will reduce noticeably. If the condition is allowed to become severe, a Stationary Regeneration may not be possible, and the DPF may require removal and treatment using specialized equipment. Therefore, to minimize disruption of your bus operation, the regeneration-related alerts should be heeded and responded to at their early stages as a matter of routine.

Aftertreatment Terms

The following summarizes some of the terms associated with the exhaust systems of Blue Bird buses equipped with 2010 emission standards compliant engines. Both the driver and technician should become familiar with the following terms:

Aftertreatment. The process of catalytically converting and filtering engine exhaust in order to reduce emissions, and of purging the exhaust system of accumulated exhaust residue.

DPF (Diesel Particulate Filter). A component in the exhaust system which takes the place of a traditional muffler. A DPF contains a special dissimilar metals filter which traps particulate accumulation (soot), which is then converted to carbon dioxide by the aftertreatment process. The Cummins DPF also contains a catalytic converter.

Regeneration. The process of cleaning accumulated soot from the filtering components inside the DPF. Regeneration occurs at high exhaust system temperatures to turn the soot into carbon dioxide gas. Regeneration can be thought of as conceptually similar to the clean cycle of a self-cleaning oven.

WARNING *Postponing regeneration beyond the early indications may result in the engine being automatically de-rated, and reduction of power while driving.*

WARNING *The aftertreatment regeneration process can cause extremely high exhaust gas temperatures hot enough to ignite or melt common materials, and to burn people.*

Carefully read, understand, and abide by all instructions, warnings, and cautions in the engine manufacturer's operator's manual (and other related engine manufacturer's literature) regarding safe operation when the HEST indicator is on.

Carefully read, understand, and abide by all instructions, warnings, and cautions in the engine manufacturer's operator's manual (and other engine manufacturer's literature) regarding safety conditions when performing Stationary regeneration.



HEST Indicator (High Exhaust System Temperature). An instrument panel indicator which appears when the exhaust temperature is unusually high due to recent regeneration. This is normal behavior of the aftertreatment system, intended to notify the driver and technician that the exhaust system temperature is high and that caution should be observed around the exhaust system.

DPF Indicator. An instrument panel indicator which displays when particulate accumulation has reached a preset level in the DPF, and regeneration is needed. The bus should either be operated with a more demanding duty cycle until the indicator goes off, or it should be scheduled for a Stationary Regeneration at a service facility.

Levels of Notification

Regeneration—the process which burns off soot accumulation in the DPF—occurs automatically as the bus is operated, as long as certain operating conditions (such as minimum speed thresholds) are met. When bus operating conditions do not provide adequate opportunity for the regeneration system to keep the DPF clear, soot begins to accumulate. A system of driver alerts keeps the driver informed when the exhaust system is in need of regeneration, and of high exhaust temperature associated with regeneration. Several levels of regeneration alerts occur in sequence, each indicating a more imperative warning.

High Exhaust Temperature Notification

The High Exhaust System Temperature (HEST) indicator appears to alert the driver when exhaust temperature is unusually high and that prudent judgement should be applied regarding the proximity of people or combustibles to the exhaust system. For example, the bus should not be parked on a surface of grass or weeds.

With the Cummins engine, the HEST indicator appears whenever the exhaust temperature is high (752°F or above), regardless of moving speed.

The driver should be familiar with and abide by all instructions, warnings, and cautions in the engine manufacturer's operator's manual regarding safe operation when the HEST indicator is on.

- The HEST alert appears in the instrument panel.
- The audible alarm sounds one beep.

HEST Notification



The HEST alert appears in the instrument panel's warning bank.



The audible alert sounds one beep.

Level 1 Regeneration Notification: DPF Indicator Appears

In low-demand operating conditions, it is possible that the regeneration system does not have sufficient opportunity to prevent particulate build-up in the DPF. The ECM senses that accumulation is occurring and that regeneration is needed. The driver is notified as follows:

- The DPF Regeneration alert activates.
- The audible alert sounds one beep.

The above indicates that regeneration of the DPF is needed at the earliest convenience. The regeneration can be accomplished in either of two ways: If practical, the bus could simply be operated for a while at a speed above the automatic regeneration threshold; or the bus could be taken to a suitable location to have a Stationary Regeneration procedure performed.

If the bus is operated at a minimum highway driving speed (40 mph Cummins), the automatic regeneration system will activate. If minimum speed is maintained long enough (usually 20-30 minutes), the automatic regeneration mode can likely reduce the soot sufficiently to cause the DPF icon to go off.

Therefore, the first appearance of the DPF icon should be perceived by the driver as a normal notification of action that needs to be taken, but not as an emergency situation. Typically, even if the bus route does not afford immediate opportunity for higher-speed operation, there is sufficient time to finish the bus route and return to the bus maintenance shop before a higher level of notification occurs. Exactly how much “warning time” the first appearance of the DPF indicator represents is dependent upon specific operating conditions. However, current data from Cummins suggest that, at this level of notification, the DPF needs to undergo regeneration within the next two to six hours of bus operation. If regeneration does not begin, a more imperative notification will activate.

Level 2 Notification: DPF Indicator Blinks

If the bus continues to be operated without taking the measures indicated by a Level 1 Notification (described above), particulate accumulation continues, and a more imperative notification occurs:

- The DPF Regeneration alert begins to flash.
- The audible alarm sounds continuously.
- The engine may be automatically de-rated.

The above indications should be interpreted as a more imperative alert that the exhaust system is in need of regeneration soon. As soon as practical, the bus should be operated at or above the minimum speed needed to allow automatic regeneration to activate, or a Stationary Regeneration must be performed. Again, situation-specific variables apply. Current data from Cummins suggest that at this level of notification, the DPF needs to be regenerated within the next one to two hours of bus operation. Otherwise, the third level of notification will occur.

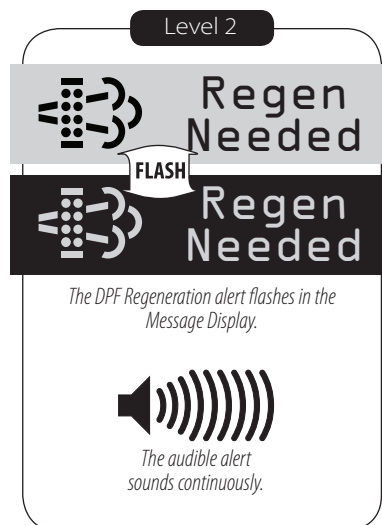
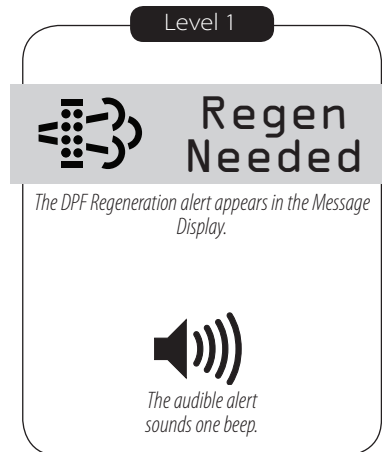



Level 3 Notification: Check Engine Indicator Appears

If the bus continues to be operated without taking the measures indicated by a Level 2 Notification, particulate accumulation worsens. These indicators are activated:

- The DPF Regeneration alert continues to flash.
- The audible alert sounds continuously.
- The engine is automatically de-rated.
- The Check Engine alert appears.

The above indicates that a Manual Regeneration must be performed as soon as possible. Because the engine is automatically de-rated it may not be possible to drive at sufficient speed to cause active regeneration to occur.

With the Cummins engine, depending upon the severity of the accumulation, the regeneration switch may not be allowed to initiate a regeneration without use of Cummins's PC-based diagnostic software, Insite.

Level 4 Notification: Stop Engine Indicator Appears

If the bus continues to be operated without taking the measures indicated by a Level 3 Notification, particulate accumulation reaches a critical level. Engine power is automatically *further* de-rated by the ECM. These indicators are activated:

- The DPF Regeneration alert deactivates.
- The audible alert sounds continuously.
- The engine is further de-rated.
- The Check Engine alert deactivates.
- The red Stop Engine alert appears.

The above indicates that accumulation has progressed to critical levels and the bus should be stopped with the engine off as soon as it is safe to do so. The bus should remain shut down until the aftertreatment system has been serviced.

With the Cummins engine, the regeneration switch will not be allowed to initiate a regeneration without use of Cummins's PC-based diagnostic software, Insite.

Removal and cleaning of the DPF using specialized equipment may be required.

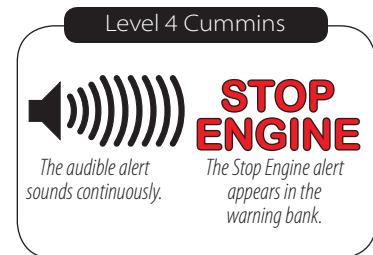
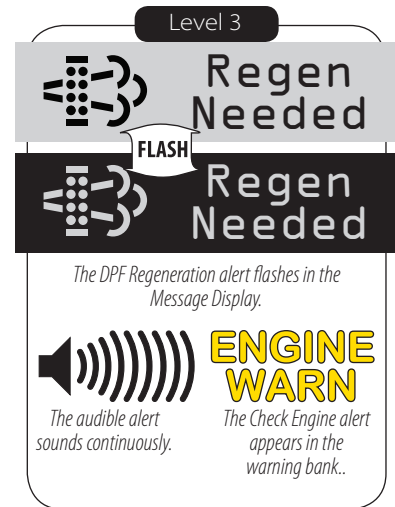

Stationary Regeneration Precautions

During active regeneration, the exhaust system can reach extremely high temperatures. Automatic active regeneration, which occurs while driving the bus, is programmed to occur only when the bus is moving at a minimum speed, and it stops when the vehicle slows or stops.

With the Cummins engine, the HEST indicator appears whenever the high temperature condition exists.

When performing a Stationary Regeneration, the entire process occurs for an extended period while the bus is stopped. It is therefore critical that prudent human safety and fire hazard precautions are followed. Those precautions include:

- Read, understand, and abide by all the precautions pertaining to regeneration procedures in the engine manufacturer's Operator's Manual.
- If at all possible, the Stationary Regeneration procedure should be conducted at a service facility by trained technicians.
- The Driver's first priority is the safety of the passengers. If a Stationary Regeneration must unavoidably be done by the Driver under a qualified technician's direction, alternate transportation should be arranged first, or passengers should be removed under proper supervision to a location away from the bus.
- Select an appropriate location to park the vehicle.
 - Choose a surface that will not burn or melt under high temperature, such as clean concrete or gravel, *not grass or asphalt*.
 - Ensure that nothing that can burn, melt, or explode (gasoline, wood, paper, plastics, fabric, compressed gas containers, hydraulic lines) is near the exhaust outlet. Abide by all instructions, warnings, and cautions in the engine manufacturer's operator's manual regarding safe operation when performing a Stationary Regeneration.
- Park the bus securely.
 - Set the parking brake. Put the transmission in Neutral. Chock the wheels.



- Secure the exhaust area.
 - If bystanders might enter the area, set up barriers to keep people safely away from the exhaust outlet.
 - If the procedure is performed indoors at a service facility, attach an exhaust discharge pipe rated for at least 1500°F.
 - Keep a fire extinguisher nearby.
- Check exhaust system surfaces to confirm that no tools, rags, grease, debris or any other objects are on or near the exhaust system.
- Start the engine.
- Operate the Regeneration Switch to begin the regeneration process.
- Monitor the process. If any unsafe condition occurs, shut off the engine immediately. During the regeneration process, the engine may change speed, and the turbocharger may whistle. When the process is complete, the engine will return to normal idle speed. Exhaust gas and exhaust surface temperatures will remain elevated until they have had time to cool to normal levels.

SCR System in Blue Bird Buses

Selective Catalytic Reduction (SCR) is a Nitrous Oxide control technique for diesel engine exhaust. The SCR system uses Diesel Exhaust Fluid (DEF) a nitrogenous compound which readily decomposes into ammonia. The system process involves the injection of DEF into the exhaust over a catalyst. The DEF converts to ammonia in the exhaust stream. This ammonia then reacts with NO_x and produces harmless nitrogen (N₂) and water (H₂O).

The DEF-SCR system basically consists of three elements:

SCR Catalyst. The SCR is located in the exhaust stream rear of the Decomposition Reactor. It is similar in outward appearance to a small muffler. The device is comprised of a canister containing the SCR catalyst which uses the ammonia contained in the injected DEF to react with NO_x. This reaction is temperature dependent and transforms the NO_x into harmless nitrogen gas and water.

DEF dosing system. DEF is supplied from a chassis mount tank to a Supply Module. The Supply Module is controlled by the Dosing Control Unit. The Supply module and the Dosing Control Unit are located inboard the frame rail. The Supply Module uses a very accurate metering and pumping system to supply DEF to the Dosing Module located at the Decomposition Reactor in the exhaust system. The amount of the DEF injected into the exhaust is controlled by the ECM. Water evaporates quickly and the DEF turns into ammonia when in contact with hot exhaust gases.

Diesel Exhaust Fluid. DEF is carried on board the bus as an aqueous urea solution in a 15 gallon storage tank clearly identified as DEF. The storage tank is sized to minimize operator filling, but within packaging and weight constraints of the vehicle. Diesel Exhaust Fluid is urea mixed with water to a 32.5% solution. DEF solution is a clear liquid with a weak ammonia odor.

The SCR system consumes DEF at a rate of approximately 2% of the amount of fuel used, depending on bus operation. Therefore a 15 gal tank of DEF will treat approximately 750 gallons of diesel fuel.

The DEF tank level indicator can be found in quadrant 3 of the message display center located on the instrument cluster. This display provides a constant reading indicating the percent of DEF in the tank. If a problem is identified with the amount of fluid or the quality of the DEF, a priority message will appear in quadrant 1 of the message display center indicating the fault.

Keeping adequate levels of DEF in the tank is crucial to the operation of the SCR system. When low levels in the DEF tank are indicated, refill the tank using only approved DEF solution. The DEF has its own tank and fill port with a cap. You will notice the fill port is smaller than the diesel fuel port. This is to prevent putting diesel fuel into the DEF tank. Conversely, care should be given not to put DEF in the diesel fuel tank. Read all decals carefully before refilling. When filling the DEF tank ensure the vehicle is on level ground and insert the fill station nozzle as far as possible into the fill port adapter to ensure proper auto-shutoff levels.

CAUTION DO NOT overfill the DEF reservoir. DEF will freeze and expand at temperatures below 12° F (-11°C). If the reservoir is overfilled and freezes, the expansion of the frozen DEF will cause catastrophic damage to reservoir and/or the vehicle SCR system.

Refer to Blue Bird and Cummins Service Manuals for detailed description of the aftertreatment system.



DEF Fill Door



DEF Fill located to the left of the entrance door.



Diesel Fill

CAUTION DO NOT put diesel fuel in the DEF tank. DO NOT put DEF in the fuel tank of the bus.



DEF Levels of Priority Notification

A system of driver alerts keeps the driver informed of when the DEF is in need of service. When fluid is low or contaminated, several levels of alerts occur in sequence, each indicating a more imperative warning. When priority warnings occur, they will appear in Quad 1 of the Message Display in lieu of the odometer reading while Quad 3 indicates fluid level in the DEF tank at all times. The notifications are as shown below.

DEF Level 1. When the DEF level reaches 10% in the tank, a **DEF LEVEL LOW** warning will appear in Quad 1 of the Message Display at which point the amber DEF warning icon will appear in the lower left warning bank. This warning is accompanied with a single beep.

DEF Level 2. When the DEF level reaches 5% in the tank, a **DEF LEVEL CRITICAL** warning will appear in Quad 1 of the Message Display, this DEF LEVEL CRITICAL warning display will flash from positive to negative and the amber DEF Warning icon will remain in the lower left warning bank. This warning is accompanied with repeating beeps.

DEF Level 3. When the DEF level reaches 2.5% in the tank, a **DEF LEVEL DERATE** warning will appear in Quad 1 of the Message Display, this DEF LEVEL DERATE warning display will flash from positive to negative. The amber DEF Warning icon will commence flashing in the lower left warning bank and an additional amber Engine Warning light will appear. At this point a 25% engine torque derating will occur.

Level 1

DEF Level Low

The DEF Level alert appears in the Message Display.

The DEF Warning will appear in the Warning Bank.

The audible alert sounds one beep.

Level 2

DEF Level Critical

FLASH

DEF Level Critical

The DEF Level alert appears in the Message Display.

The DEF Warning will appear in the Warning Bank.

The audible alert beeps repeatedly.

Level 3

DEF Level Derate

FLASH

DEF Level Derate

The DEF Level alert appears in the Message Display.

The DEF Warning will flash in the Warning Bank.

ENGINE WARN

The Engine Warning will appear in the Warning Bank.

The audible alert beeps repeatedly.

DEF Level 4. When the DEF level reaches 0% in the tank, a **DEF TANK EMPTY** warning will appear in Quad 1 of the Message Display, this DEF TANK EMPTY warning display will flash from positive to negative. The amber DEF Warning icon will continue flashing in the lower left warning bank and the amber Engine Warning light will be illuminated. Continued 25% engine torque derating.

DEF Level 5. When DEF system can no longer maintain pressure, a **DEF SPEED LIMIT** warning will appear in Quad 1 of the Message Display, this DEF SPEED LIMIT warning display will flash from positive to negative. The amber DEF Warning icon will continue flashing in the lower left warning bank. The amber Engine Warning light will remain illuminated and a red Stop Engine light will appear. At this point a 5 MPH speed limit will be introduced with the 25% engine torque derating.

Level 4

DEF Tank Empty

FLASH

DEF Tank Empty



The DEF Level alert appears in the Message Display.

ENGINE
WARN

The Engine Warning will appear in the Warning Bank.



The DEF Warning will flash in the Warning Bank.



The audible alert beeps repeatedly.

Level 5

DEF Speed Limit

FLASH

DEF Speed Limit



The DEF Level alert appears in the Message Display.

ENGINE
WARN

The Engine Warning will appear in the Warning Bank.



The DEF Warning will flash in the Warning Bank.

STOP
ENGINE

The Stop Engine Light will appear in the Warning Bank.



The audible alert beeps repeatedly.



DEF Type Level 1. When incorrect fluid or mixture is introduced into the tank, a **DEF FLUID TYPE** warning will appear in Quad 1 of the Message Display, this DEF FLUID TYPE warning display will flash from positive to negative. The amber Engine Warning light will appear in the lower left warning bank. The integrity of the DEF solution needs to be checked using a refractometer. DEF system service should be attained within 10 hours or subsequent levels of derating will occur.

DEF Type Level 2. The **DEF FLUID TYPE** warning in Quad 1 of the Message Display continues to flash from positive to negative. The amber Engine Warning light will appear in the lower left warning bank. At this point a 25% engine torque derating will occur. DEF system service should be attained within 10 hours or subsequent levels of derating will occur.

DEF Type Level 3. After 10 Hours at level 2, a **DEF SPEED LIMIT** warning will appear in Quad 1 of the Message Display, this DEF SPEED LIMIT warning display will flash from positive to negative. The amber Engine Warning light will remain illuminated and a red Stop Engine light will appear. At this point a 5 MPH speed limit will be introduced with the 25% engine torque derating.

Level 1

DEF Fluid Type

FLASH

DEF Fluid Type

The DEF Type alert appears in the Message Display.

ENGINE WARN

The Engine Warning will appear in the Warning Bank.

Level 2

DEF Fluid Type

FLASH

DEF Fluid Type

The DEF Type alert appears in the Message Display.

ENGINE WARN

The Engine Warning will appear in the Warning Bank.

Level 3

DEF Speed Limit

FLASH

DEF Speed Limit

The DEF Type alert appears in the Message Display.

ENGINE WARN

The Engine Warning will appear in the Warning Bank.

STOP ENGINE

The Stop Engine Light will appear in the Warning Bank.

SCR Fault Level 1. When an SCR System Fault is detected, an **SCR SYSTEM FAULT SEE ENGINE DIAGNOSTIC** warning will appear in Quad 1 of the Message Display, this SCR SYSTEM FAULT SEE ENGINE DIAGNOSTIC will flash from positive to negative. The amber Engine Warning light will appear in the lower left warning bank. Engine diagnostic codes should be recorded and appropriate repairs should be made. DEF system service should be attained within 10 hours or subsequent levels of derating will occur.

SCR Fault Level 2. After 10 Hours at level 1 the amber Engine Warning light *WILL* be illuminated and a 25% engine torque derating will occur. DEF system service should be attained within 30 hours or subsequent levels of derating will occur.

SCR Fault Level 3. After 30 Hours at level 2 the amber Engine Warning light and the Stop Engine light *WILL* be illuminated. At this point a 5 MPH speed limit will be introduced with a 25% engine torque derating.

Level 1

**SCR System Fault
See Engine Diagnostic**

FLASH

**SCR System Fault
See Engine Diagnostic**

The SCR Fault alert appears in the Message Display.

**ENGINE
WARN**

*The Engine Warning
will appear in the
Warning Bank.*

Level 2

**SCR System Fault
See Engine Diagnostic**

FLASH

**SCR System Fault
See Engine Diagnostic**

The SCR Fault alert appears in the Message Display.

**ENGINE
WARN**

*The Engine Warning
will appear in the
Warning Bank.*

Level 3

**SCR System Fault
See Engine Diagnostic**

FLASH

**SCR System Fault
See Engine Diagnostic**

The SCR Fault alert appears in the Message Display.

**ENGINE
WARN**

*The Engine Warning
will appear in the
Warning Bank.*

**STOP
ENGINE**

*The Stop Engine Light
will appear in the
Warning Bank.*



TRANSMISSIONS

Allison Automatic Transmission

Important: Allison supplies far more detailed information about your particular transmission than space allows in this manual. Although we try to cover the most important points here, it is imperative that you read and understand the Allison Transmission Operator's Manual for more details about operation, care, and maintenance. If you did not receive this manual with your bus, please contact the transmission supplier. Both Blue Bird Corporation and Allison Transmissions continually strive to improve the quality and performance of their respective products. For this reason, information and instructions in the Allison Transmission Operator's Manual supplied with the bus will take precedence over the general information in this publication.

Allison Model 3000 Series Transmission

The Allison electronic transmission provides five forward speeds and one reverse. Fourth gear is a 1-to-1 ratio while the fifth gear is an overdrive with a 0.75-to-1 ratio. The push-button shift selector is located on the right area of the dash. The transmission and selector must be in neutral to start the engine.

The service brake must be applied before the transmission will shift from neutral to drive or reverse. If an attempt is made to shift the transmission into drive or reverse without applying the service brake it will remain in neutral, an audible alarm will sound, and the Range Inhibit light on the instrument panel will come on. If this occurs, apply the service brake and then select the desired gear.

Transmission and shift selector will return to "N" when engine is stopped and power switched off. If it does not return to "N" or if it starts in any other gear, the unit has malfunctioned. Seek service immediately.

The push-button shift selector has "R", "N", "D", down arrow, up arrow, a "MODE" button, and a digital display. When a range button is pressed, a tone sounds, the "SELECT" indicator displays the chosen operation (if the Electronic Control Unit [ECU] determines the shift is acceptable), and the transmission shifts to the starting range as indicated on the monitor display. In "DRIVE", selection of a specific gear can be accomplished by pressing the "UP" or "DOWN" arrow buttons. Conditions resulting in the "CHECK TRANSMISSION" light, located in the instrument cluster, will disable the pad and no tones will sound (see Check Transmission Light).

The "MODE" button, located on the push-button shift selector, activates an alternate shift schedule. By default, the start up is in primary or power mode. Pressing the "MODE" button causes the transmission to enter the economy mode. The display will indicate the economy mode is engaged. In economy mode, the transmission shifts to higher gear at lower engine rpm.

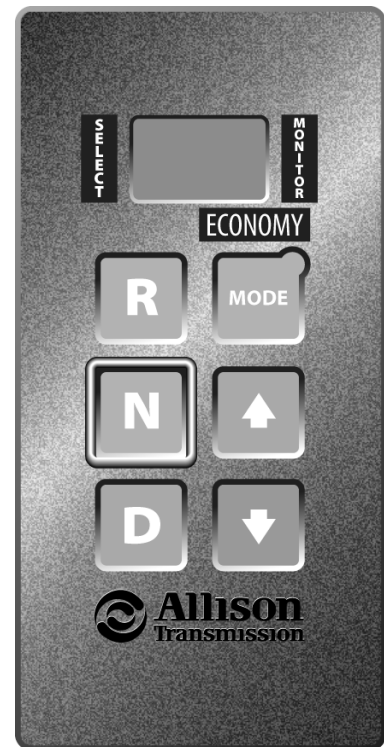

Allison Model 3000 Series Transmission Gear Selection

WARNING *When leaving the vehicle while the engine is running, the operator must ensure the transmission is in "Neutral", the parking brake is engaged, and the wheels are chocked. The vehicle may move unexpectedly without these precautions.*

R—Reverse. The vehicle must be completely stopped before shifting from forward to reverse or from reverse to forward. The select indicator and the monitor will display "R" when the vehicle is in reverse.

N—Neutral. Use neutral to start the engine, to check vehicle accessories, and for extended periods of engine idle operation. Under normal operation, the transmission is directed by the ECU to neutral during the startup procedure. This occurs automatically with the push-button selector. If the vehicle starts in any range except neutral, seek service immediately.

WARNING *Do not allow your vehicle to coast in neutral. This practice can result in transmission damage. Engine retarding and braking assistance is not available when the transmission is in neutral. It may not be possible to get the transmission back into gear while the bus is moving.*

D—Drive. When "D" is selected, the vehicle will start to move in first gear and the transmission will upshift automatically through each gear as the speed increases. As the vehicle slows down, the transmission will downshift automatically. The select indicator will display the highest gear available and the monitor will display the current operating gear.

2, 3, 4, 5 Gears. Occasionally, the road conditions, load, or traffic conditions will make it desirable to restrict the automatic shifting to a lower gear. Positions "5", "4", "3", and "2" provide progressively greater engine braking for going down grades (the lower the gear, the greater the braking effect). Push the "Up" or "Down" arrow to the desired gear. The select indicator will display your choice and the monitor will display the gear the bus is operating in.

1 Gear. Use position "1" gear when pulling through mud and deep snow, when maneuvering in tight spaces, or while driving up or down grades. Low gear provides the vehicle maximum power and maximum engine braking power.

The transmission incorporates a hold feature to prohibit upshifting beyond the gear selected during normal driving. For downhill operation, however, the transmission may upshift beyond the selected gear when the engine's governed speed is exceeded, and damage to the engine is possible.



Allison Model 2000 Series Transmission

The Allison transmission provides five forward speeds and one reverse. The transmission is controlled with the selector lever located to the driver's right. The selector lever must be in the "N" position (neutral) to start the engine. If the engine starts in any other position, the neutral start switch is malfunctioning and should be repaired immediately. Use "D" (drive) for all normal driving conditions. The service brake must be applied before the transmission will shift from neutral to drive or reverse. If an attempt is made to shift the transmission into drive or reverse without applying the service brake it will remain in neutral, an audible alarm will sound, and the Range Inhibit light on the instrument panel will come on. If this occurs, apply the service brake and then select the desired gear. The vehicle will begin to move in first gear, and as you press the accelerator, the transmission will upshift automatically. As the vehicle slows down, the transmission will automatically downshift to the correct gear. Use "1" and "2" when the road, load, or traffic conditions make it desirable to restrict the automatic shifting to a higher range. When the conditions improve, return the range selector to the normal driving position D. These positions also provide progressively greater engine braking power (the lower the gear range, the greater the braking effect). Use "1" when pulling through mud or snow or driving up steep grades. This position provides maximum engine braking power. Use "R" (reverse) for backing the bus. The bus should be completely stopped before shifting from a forward gear to reverse. Reverse gear provides the greatest traction.



Allison 2000 Series Transmission Gear Selection

WARNING *When leaving the vehicle while the engine is running, the operator must be sure the transmission is in Neutral, the parking brake is engaged, and the wheels are chocked. The vehicle may move unexpectedly without these precautions.*

R—Reverse. Use reverse to back up the vehicle. The vehicle must stop completely, with the engine returning to idle speed, before shifting from forward to reverse or from reverse to forward. If your bus is equipped with a reverse warning signal, it will activate when shift selector is in reverse.

CAUTION *Do not idle in "R" (reverse) for more than five minutes. Extended idle time in "R" (reverse) may cause transmission overheating and damage. Always select "N" (neutral) whenever time at idle exceeds five minutes.*

N—Neutral. Use neutral to start the engine, to check vehicle accessories, and for extended periods of engine idle operation. If the vehicle starts in any other range, seek service immediately.

WARNING *Do not allow your vehicle to coast in neutral. This practice can result in transmission damage. Engine retarding and braking assistance is not available when the transmission is in neutral. It may not be possible to get the transmission back into gear while the bus is moving.*

D—Drive. When "D" is selected, the vehicle will begin to move in first gear and the transmission will upshift automatically through each gear as speed increases. As the vehicle slows down, the transmission will downshift automatically.

CAUTION Do not idle in "D" (drive) for more than five minutes. Extended idle time in "D" (drive) may cause transmission overheating and damage. Always select "N" (neutral) whenever time at idle exceeds five minutes.

1, 2, D Gears. Occasionally, the road conditions, load, or traffic conditions will make it desirable to restrict shifting to a higher gear. Positions "D", "2", and "1" provide progressively greater engine power and braking for going down grades (the lower the gear, the greater the braking effect).

1 Gear. Use position "1" gear when pulling through mud and deep snow, when maneuvering in tight spaces, or while driving up or down grades. Low gear provides the vehicle with its maximum power and maximum engine braking power.

Park. If your bus is equipped with a "Park" selection, use it only after coming to a complete stop, and then apply the parking brake. Do not rely upon the transmission park pawl position alone to prevent the bus from rolling.

Range Inhibited Light

Under certain operating conditions, the Transmission Control Module (TCM) may determine that it is necessary to restrict gear selection to protect the transmission from damage and provide safer operating conditions. When this happens, the "RANGE INHIBITED" warning light will activate, and the transmission may not respond to the operator's commands. Please see the Range Inhibited Light and Shift Inhibits section of the Allison Transmission operator's manual for more information.

Check Transmission Light

The "CHECK TRANSMISSION" light is located in the instrument panel. The electronic control system is programmed to inform you if operating parameters have been exceeded and to automatically take action to protect the transmission. A diagnostic code will be registered when the "CHECK TRANSMISSION" light is on.

When the engine is started, the "CHECK TRANSMISSION" light turns on for a few seconds. This momentary indication shows that the lighting circuit is working properly.

If the light illuminates after startup, a problem has been detected. A diagnostic code will be recorded and shifts may be restricted. Depending on the problem's severity, the operator may continue driving to reach service assistance. The TCM may restrict upshifts and downshifts. Please see your Allison Transmission operator's manual for more details on how shifts may be inhibited.

CAUTION If the transmission will not shift into "D" (drive), or "R" (reverse), it may be because of an adverse operating condition such as; engine RPM too high or service brakes not applied when attempting to shift from neutral. Check for the "RANGE INHIBITED" message or "CHECK TRANS" light. See the appropriate section of the Allison transmission manual.



Allison Automatic Transmission Driving Tips

Accelerator Control

The pressure of your foot on the accelerator pedal influences the automatic shifting. An electronic signal tells the ECU how far the driver has depressed the pedal. This provides the accurate shift spacing and control necessary for maximum performance.

Downshift or Reverse Inhibitor Feature with Allison 3000 PTS Transmission

Although there is no limitation on upshifting, there is a limit on downshifting and shifts from neutral into drive or reverse. If a downshift or neutral-to-range shift is selected when the engine speed or throttle position is too high, the ECU/TCM will not allow the shift until reaching a lower speed. If idle speed is too high, shifts to range are prohibited. A continuous "beep" tone sounds when reverse is selected during forward movement or if a neutral-to-range shift is selected at too high an engine speed.

Cold Weather Starts

Most Allison transmissions are programmed to restrict operation until operating temperature is reached. When the transmission fluid temperature is below -25°F (-32°C), the transmission will not shift into an operating range and the "Check Transmission" light will be illuminated. When the transmission fluid temperature is between -24°F and 20°F (-31°C to -7°C), the transmission will operate in 1st, 2nd, or Reverse only. If there is no other problem with the transmission, the "Check Transmission" light will not be illuminated. For transmission fluid temperatures above 20°F (-7°C), the transmission will shift and operate in a normal manner. Be sure to read and understand the cold weather operation instructions in the Allison Transmission™ Operator's Manual supplied with the bus.

Using the Engine to Slow the Vehicle

To use the engine as a braking force, shift the range selector to the next lower range. If the vehicle is exceeding the maximum speed for a lower gear, use the service brakes to slow the vehicle to an acceptable speed where the transmission may be downshifted safely. After reaching the lower speed, the ECU will automatically downshift the transmission. Engine braking provides good speed control for going down grades. When the vehicle is heavily loaded, or the grade is steep, it may be desirable to select a lower range before reaching the grade. If engine-governed speed is exceeded, the transmission will upshift automatically to the next range.

CAUTION *The transmission incorporates a hold feature to prohibit upshifting above the range selected during normal driving. For downhill operation, select a lower transmission range. However, if engine governed speed is exceeded, the transmission may upshift to the next higher range. Use the vehicle service brakes to prevent exceeding engine governed speed in the held range.*

WARNING *If you only downshift or only use the service brakes when driving down a steep grade, you can lose control. To maintain control, combine downshifting, braking, and other retarding devices. Downshifting to a lower transmission range increases engine braking and helps maintain control. The transmission has a feature to prevent automatic up shifting above the lower range selected. However, during downhill operation, if the engine governed speed is exceeded in the lower range, the transmission may upshift to the next higher range. This will reduce braking and could cause a loss of control. Apply the vehicle service brakes or other retarding device to prevent exceeding engine governed speed in the lower range selected.*

Transmission Indicators

Check Transmission Indicator

While driving, be alert to any abnormal shifting, unusual sounds or vibrations, smells, or frequent illumination of a transmission priority message. If you experience any of these, get service immediately.

Transmission Oil Temperature

An oil temperature readout in the message display center on the instrument panel indicates the transmission oil temperature. Extended operations at low vehicle speeds with the engine at full throttle can cause excessive oil temperatures. These temperatures may overheat the engine cooling system and lead to engine and/or transmission damage.

If excessive temperature is indicated by the engine coolant temperature gauge, stop the vehicle and check the cooling system. If the cooling system appears to be functioning properly, shift to neutral and accelerate the engine to 1,200–1,500 rpm. This will reduce the transmission temperature to operating level within two or three minutes. If high temperature persists, stop the engine and have the overheating condition investigated by service personnel.

If the transmission oil temperature readout indicates excessive temperature, check the oil level in transmission (refer to the Oil Check Procedure in your Allison Transmission Operator's Manual). Stop the vehicle and shift to neutral. Accelerate the engine to 1,200–1,500 rpm. The temperature should return to normal within two or three minutes before the vehicle resumes operation. Normal temperature for both on and off-highway operation is 160° to 200° F. Oil temperature should never exceed 250° F. If the sump oil temperature reaches 250° F, the TCM will inhibit operation in the higher gears and turn on a priority message in the message display center indicating high transmission temperature.

If high temperature in either engine or transmission persists, stop the engine and have the overheating conditions investigated by maintenance personnel.

CAUTION *The engine should never be operated for more than 30 seconds at full throttle with the transmission in gear and the vehicle not moving. Prolonged operation of this type will cause the transmission oil temperature to become excessively high and will result in damage to the transmission.*



Transmission Service Prognostics

Service prognostics is standard equipment on all Allison Gen 4 transmissions and requires the use of Allison approved TES 295 or TES 389 fluids and Control Main filter. Prognostics is used to predict the need for transmission maintenance. Transmission operating parameters monitored by the prognostics feature are:

1. Oil Life Monitor
2. Filter Life Monitor
3. Transmission Health Monitor

2000 Series Product

When a specified service threshold is detected for one of the parameters listed above, the TRANS SERVICE indicator in the instrument panel will illuminate to alert the operator to the need for action. Failure to perform the required service and reset the TRANS SERVICE indicator after 100 hours of operation will result in the CHECKTRANS and the TRANS SERVICE indicators illuminating. When the CHECK TRANS indicator illuminates the TCM will register a fault code which will require the use of Allison DOC® for PC-Service Tool to clear the code after the required service has been performed.

Oil Life Monitor - The TRANS SERVICE indicator will illuminate when the remaining fluid life reaches approximately 2 percent. The indicator will remain on for two minutes after the initial selection of a drive range. This condition will occur at each startup cycle thereafter until service has been performed. The indicator indicates a required change of the transmission fluid.

After the required service has been performed the TRANS SERVICE indicator can be reset with the Allison DOC® For PC-Service Tool, or by selecting N-D-N-D-N-R-N on the shift selector, pausing briefly (less than 3 seconds) between each selector movement. The ignition must be on and the engine must be off before attempting to reset.

Filter Life Monitor - The TRANS SERVICE indicator will flash after reaching time and mileage parameters set in the control module. This indicates the transmission filter needs servicing. It will flash for two minutes after selecting D (Drive) for each startup cycle until service is performed and the indicator is reset.

After the required service has been performed the TRANS SERVICE indicator can be reset with the Allison DOC® For PC-Service Tool or by selecting N-D-N-D-N-R-N on the shift selector, pausing briefly (less than 3 seconds) between each selector movement. Be sure the ignition is on and the engine is not running.

Transmission Health Monitor - The TRANS SERVICE indicator will illuminate when the remaining clutch life reaches approximately 10 percent, or if the running clearance exceeds maximum value which may indicate a non-wear-related issue. The indicator will illuminate and remain on until the required service is performed and the indicator reset.

The indicator will reset automatically upon elimination of the clutch clearance condition which initiated it. The indicator can also be reset using the Allison DOC® For PC-Service Tool if necessary.

3000 Series Product

Electronic shift selectors used with 3000 series transmissions have an integrated service icon in the shape of an open-end wrench located between the SELECT and MONITOR displays, which illuminates or flashes when a specified service threshold is reached for one of the three prognostic parameters.

When service is due for Allison 3000/4000 Series transmissions, a wrench icon on the shift selector's digital display alerts the operator. You can check the status of all three prognostics (oil, filter, clutch) simply by advancing through the shift selector's display using the diagnostic button or the up/down arrow buttons.



SERVICE ICON

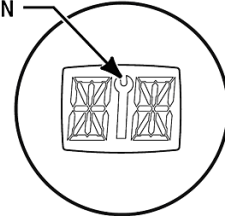

When the fluid is due for a change:

The wrench icon stays illuminated for two minutes after the Drive range is selected.



When the filter(s) is due for a change:

The wrench icon flashes on and off for two minutes after the Drive range is selected.



When clutch maintenance is due:

The wrench icon comes on and stays on in all ranges.

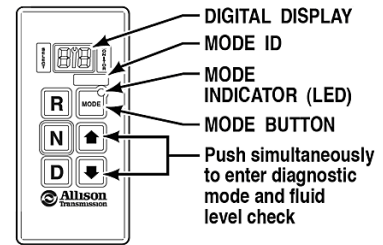
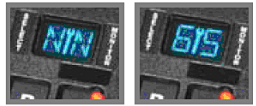



BRAKING

Antilock Braking System (ABS)

In a vehicle equipped with an antilock braking system (ABS), motion sensors detect the speeds at which the wheels move. These sensors transmit this information to an Electronic Control Unit (ECU). If the wheels start to lock, the ECU signals the modulator assembly to regulate the brake pressure of each wheel.

An ABS indicator lamp on the dash (see "Indicator Light Panel" in Instrument Panel section) warns the driver of possible system faults and provides blink code information to diagnose the system. If this light is activated during normal vehicle operation, the driver may complete the trip, but the vehicle must be serviced as quickly as possible.

Hydraulic Brakes

WARNING Do not tap into the brake system or the power steering system to provide pressure for accessories. Tampering with either of these systems could result in loss of braking ability and/or steering ability.

CAUTION Hydraulic brake systems are power-assisted. Braking capacity is reduced without engine assist. Do not move bus with dead engine.

The electric power backup pump will operate whenever the engine is not operating and the key switch is in the ON position, or when the key is in the "OFF" position and the brake pedal is depressed. Test daily by feeling for the electric motor operation while applying the brakes with the engine not operating, or when the key switch is in the "ON" positions and the engine is not operating. Initially, the pedal will be hard to push, but will become softer as the electric motor starts.

WARNING Do not drive the bus when the electric backup pump does not operate properly.

Dual Brake System

The dual brake system allows the driver diminished brake capacity in case either the front or the rear brake circuit fails.

CAUTION When one section of the dual system fails, the following conditions will exist.

1. Bus stopping distance will increase. Drive the bus only with extreme caution. Service immediately!
2. The brake pedal will be softer to push.
3. The brake pedal will travel farther than normal.

Brake Warning System

The brake warning system includes a buzzer and a red warning bank light labeled "BRAKE PRESSURE". The light and buzzer will activate during the following conditions:

- Engine is running, brakes not applied, with a loss of electrical power to the electric backup pump motor.
- Engine is running, brakes not applied, with a loss of power assist from the power steering pump.
- Engine is running, brakes are applied, and either the front or rear section of the system has failed. The backup pump, buzzer, and light will remain on even after the brake pedal has been released.
- Engine is not running, brakes are not applied, but ignition key is "ON". This condition should happen every time the driver starts the bus. The bus should not be driven if the backup pump system is not working. The backup system should go off when the engine starts.
- Engine is not running, brakes are applied, and ignition is in ON position. This is a method for checking the backup pump.

With the engine not running and the ignition "OFF", a depressed brake pedal will cause the backup motor to run with no light and buzzer. The backup system should go off when the pedal is released. Without the assist of the power steering pump and without the assist of the backup pump, the master cylinder will allow the brakes to be applied. However, brake capacity will be very limited and the bus should not be driven under these conditions.



Parking Brake (Hydraulic Brakes)

A Blue Bird ALL AMERICAN equipped with hydraulic brakes employs a foot-operated parking brake, located to the Driver's lower left. When the driver presses this lever into the engaged position, a mechanical linkage causes a brake shoe assembly to close around a brake drum attached to the driveshaft, preventing the bus from moving.

CAUTION *This type parking brake becomes inoperative if the driveshaft is disconnected, as when the bus is being prepared for towing.*

The mechanical parking brake must be kept adjusted properly for maximum holding power. When the parking brake is properly adjusted, the lever is designed to require a minimum of 130 pounds of pressure to apply the parking brake. Always apply the brake fully, pressing it down to achieve a fourth "click" of its detent setting.

WARNING *Improper adjustment of the parking brake can significantly reduce the holding ability of the parking brake system.*

To release the parking brake, apply the service brake to prevent movement when the parking brake is released. Then grasp the parking brake release lever with the left hand and pull until the Park Brake is fully released.

The parking brake should hold the fully loaded bus on a 20% incline on a dry paved surface. If the incline is wet or covered with ice or snow, do not park on it. The brake will hold, but the tires may not. The parking brake is not to be used as a normal service brake, but can be used to help stop in an emergency situation.

WARNING *The parking brake is designed to hold on a 20% grade, on a clean, dry, and smooth road surface. Parking on wet, icy, snow-covered or loose aggregate surface will greatly diminish braking efficiency and is not recommended. Always use wheel chocks.*

When the parking brake is applied, and the ignition switch is "ON", a dash-mounted yellow light labeled "PARK" will warn the driver that the brake is applied. The bus should not be driven when the parking brake is applied. Doing so will prematurely wear the parking brake or damage other drive train components.

CAUTION *Always release the parking brake fully. Leaving it in a partially released position can allow the shoes of the parking brake mechanism to drag while the bus is operated, resulting in overheating and accelerated wear of the parking brake shoes and drum.*

WARNING *The parking brake functionality relies on the rear wheels remaining in contact with the surface the bus is parked on. If one or both wheels are lifted off the surface the park brake will not function and the bus may move resulting in potential bodily harm or death.*

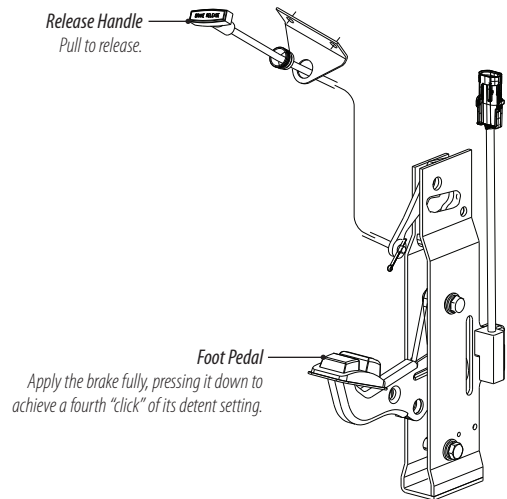

Hydraulic Brake/Throttle Interlock System (Optional)

The hydraulic brakes system of some All Americans include an optional Brake/Throttle Interlock feature which, when active, automatically applies the brakes and disables the throttle when the vehicle ignition is on and the lift door is open.

An Interlock Override switch in the Driver's left switch panel enables the Driver to temporarily override the interlock system. When active, the interlock applies the service brakes. An audible alarm sounds in the event of an interlock malfunction.

When used with the existing vehicle parking brake, the brake interlock uses the vehicle's service brake system to provide additional brake holding action.

CAUTION Use only DOT 5 brake fluid in the Hydraulic Interlock Brake system reservoir.

WARNING The brake interlock is a safety device and is not intended to be used as a parking brake. The Interlock system should never be used to stop the bus. Do not open the bus door(s) while the vehicle is in motion.

The following are decals along with WARNINGS located forward of the switch panel below the driver's side window, on All Americans with hydraulic brakes.

Read Warnings and Operating Instructions prior to using.



690 Brake Lock

TO LOCK:

1. Set parking brake
2. Move lock switch to ON position

TO RELEASE:

1. Move lock switch to OFF position
2. Release parking brake

⚠ WARNING

Serious injury or death can occur if these instructions are not followed.



Vehicle equipped with Brake Lock System. Operator must read and understand operating instructions before using vehicle. Brakes will release if ignition is turned off when Brake Lock is remotely activated. Do not use Brake Lock in place of original equipment parking brake. Always set parking brake and use wheel chocks and outriggers with Brake Lock. Do not use Brake Lock for overnight or prolonged parking. Release Brake Lock before moving vehicle. Brake Lock and warning circuit are disabled if battery power is lost or disconnected.

⚠ WARNING

Serious injury or death can occur if these instructions are not followed. Opening vehicle service door causes brakes to be applied. Vehicle equipped with Door/Brake Interlock. Operator must read and understand operating instructions before using vehicle. Brakes will release if ignition is turned off when Door/Brake is remotely activated. Do not use Door/Brake for overnight or prolonged parking. Close vehicle service door before moving vehicle. Door/Brake and warning circuit are disabled if battery power is lost or disconnected.



Air Brakes

All Americans equipped with air brakes employ separate systems for the front and rear service brakes. A separate reservoir and air gauge is provided for each of these systems. A dual treadle valve is provided for operating the service brake system. In the event there is a failure in the air reservoir for the front brakes, the rear service brakes can still be applied using the treadle valve, since the two service brake systems operate independently. If there is a failure in the air reservoir for the rear service brake system, the front service brakes and the rear spring brakes can be applied through the treadle valve. This allows the operator to use a normal method of braking even though part of the system is malfunctioning. However, in the case of an air reservoir failure, the low air pressure warning buzzer will activate, indicating trouble, and the respective air gauge on the dash will show which system has lost air pressure. The bus must not be operated under those conditions, but repaired before continuing operation.

The rear spring brakes can also be controlled by a dash-mounted valve located on the lower portion of the instrument panel. The spring brakes cannot be fully released until the air reserve pressure is above 60 psi. These brakes are in the released position when the control valve is pushed in, and in the applied position when the control valve is out. In the event there is a loss in air pressure, the valve will automatically move to the brake applied position and cannot be released until the air reservoir pressure has been replenished.

Air Brake/Throttle Interlock System (Optional)

All Americans equipped with air brakes may include an optional Brake/Throttle Interlock feature which, when active, automatically applies the service brake and disables the throttle when the vehicle ignition is on and the lift or entrance door is open.

A Brake Override switch in the Driver's left switch panel enables the Driver to temporarily override the interlock system.

WARNING *The brake interlock is a safety device and is not intended to be used as a parking brake. The Interlock system should never be used to stop the bus. Do not open the bus door(s) while the vehicle is in motion.*

Parking

Use the dash mounted valve to apply the rear spring brake when parking the bus. When the parking brake is applied, and the ignition switch is ON, a dash-mounted yellow light labeled PARK will warn the driver that the brake is applied.

CAUTION *Do not attempt to move bus before spring brakes are released.*

Draining Air Tanks

Condensation must be drained from the air tanks daily. To drain tanks properly, leave the drain cocks open until all air escapes and draining stops.



HEATERS

Blue Bird heaters depend on engine generated heat to function. Heat from the engine is picked up by the engine coolant, which is pumped through the heater cores inside the bus, and then back into the engine. A typical heater inside the bus includes a heat exchanger coil, (core) and fans which move air across the coil. Air moving across the core picks up heat from the engine coolant and transfers it into the bus.

Satisfactory performance of the heaters is dependent upon:

- Adequate engine (coolant) temperature, which is controlled by the thermostat rating (which should never be higher than recommended by the engine manufacturer). Some All Americans feature optional shutters on the radiator that help to regulate engine coolant temperature.
- Coolant flow, which varies with engine speed can be increased, if necessary, with the use of an optional auxiliary water pump.
- Blower motors have multiple speeds and can be checked by operating the motors individually, while listening for variations in speed.

Heater Operation

Be sure the engine radiator is full and all coolant flow valves are open. See charts on valve location.

CAUTION *Do not leave the engine running while opening or closing valves.*

Warm the engine to operating temperature, running at up to 1,800 rpm if possible, and then turn on the heater fans and the auxiliary water pump if so equipped.

During extremely cold weather, operating the heater fans will cause the engine temperature to drop noticeably as heat from the engine is transferred into the bus. Also, the engine will generate more heat as it works under load. When the engine reaches operating temperature, the driver can control heater blower speeds for optimal defrosting and overall passenger comfort.



Control Panel Outlet Locations

The heater control panel is located on the dash to the right of the instruments. The indicated switches and levers control the motors and air outlets as shown.

The heater is located in the right front corner, forward of the entrance door. An optional auxiliary unit is located under the driver's seat. Electrical switches and mechanical diffusers control the volume and direction of airflow. The main heater has a three-speed control switch for manual low or high speed operation, and an additional maximum output position for flash defrosting or extreme conditions. All the air from the main heater blower is directed to defrosting when the main outlet and foot warmer outlet are closed.

The Noise Suppression switch on the left side switch panel turns off all heaters and radio to allow the driver to hear sounds outside the bus; for example, at a railroad crossing. When the switch is in the "on" position, neither the heater blowers nor the radio will operate.

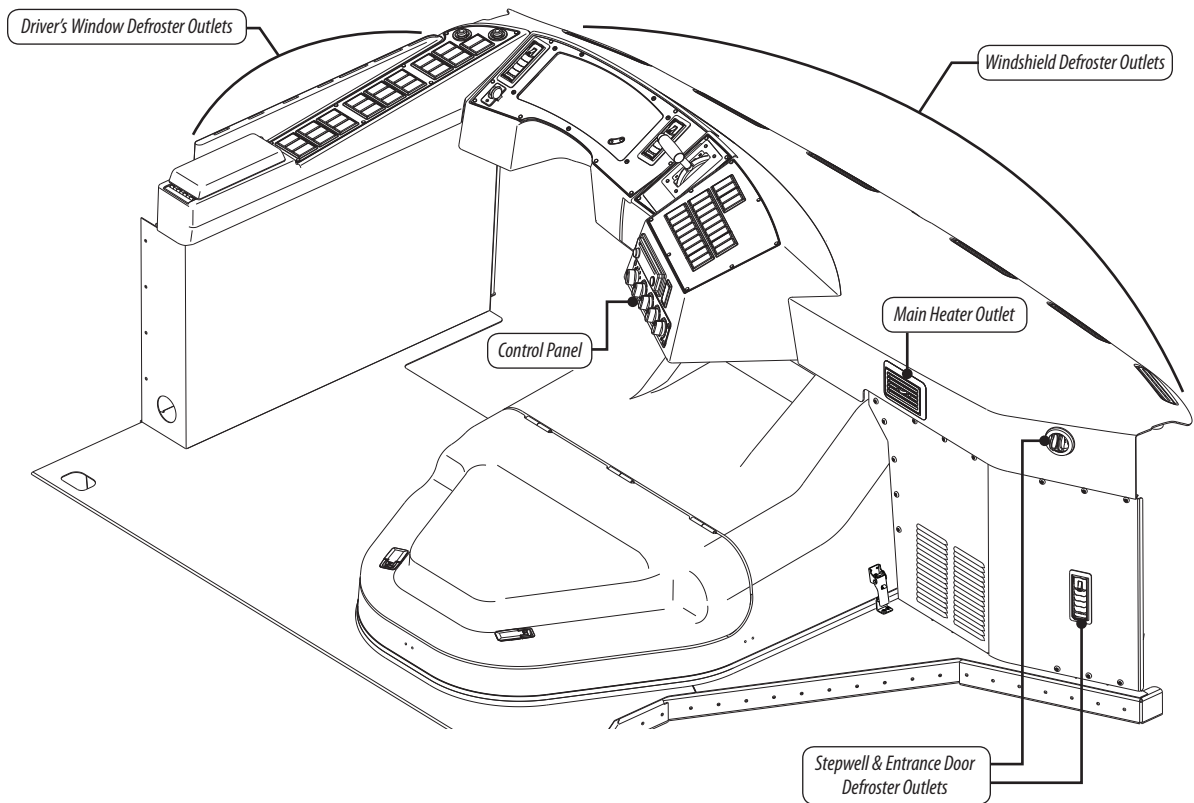
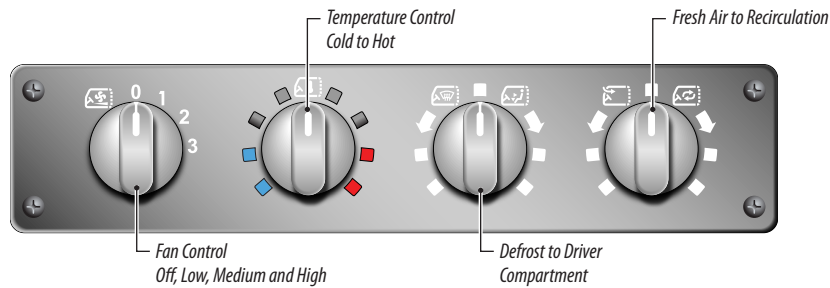

Defrosting

Windshield fogging and frosting is caused by warm, humid air coming into contact with a colder windshield, which causes the moisture in the air to condense and freeze if the windshield is cold enough. The warmer the windshield, the less moisture will condense. During initial warmup, the defroster blowers should be operated at low speed to preheat the inside of the windshield glass. If the defrosters are not turned on until after condensation starts, it is more difficult to heat the glass and drive moisture away.

As passengers are loaded, the moisture content of the air inside the bus increases. This moisture content tends to be lowered by opening the heater fresh air inlet. Conditions will be especially difficult when large passenger loads stay on board for extended periods of time, such as on a charter or over-the-road activity trip. Traveling at highway road speeds causes heat to dissipate through the windshield glass, and each passenger's breath continually adds to the air's moisture content. To reduce fogging, open the forward driver's window slightly to let the moist air escape. *Fresh air control knob should be set to full fresh air position (counterclockwise) for defrosting/defogging operation.*

Heater Defroster Location

The blower in the front main heater contributes to keeping the driver's area glass clear of fog and frost. See OUTLET LOCATION diagram. For best results, fresh air should be flowing into the heater. To inspect the fresh air intake and make sure it is working properly, open the front access panel on the curbside of bus.

Driver / Passenger Comfort

When the windows are defrosted, the other openings can be set as necessary for comfort. The adjustable diffusers on the dash can be directed toward the driver and/or passengers as desired. The optional auxiliary unit under the driver's seat has a two-speed electrical switch and it directs air upward for the driver's left side and forward around the steering column area.

Temperature Control

The temperature control knob varies the amount of engine coolant flowing through the heater system, this directly affects the temperature output of the heater. *Note: If the bus is equipped with an auxiliary fuel-fired heater, the temperature control knob must be set to the "Full Hot" (clockwise) position before the bus is switched off in order to function properly.*



Standard Heater Cut Off Valves

Valves are provided in the heater piping to permit isolation of the heating circuit from the engine coolant circuit. This is useful in case a leak occurs within the system, or to restrict the flow of hot water through the bus during warm weather.

When Valves No. 1 and No. 2 in the diagrams below are closed, engine coolant is prevented from circulating through the heaters. (This does not restrict circulation of the engine cooling circuit, so it is safe to operate the engine with the valves closed.)

CAUTION Do not operate auxiliary heater or auxiliary coolant pump with heater cutoff valves closed

Engine: Cummins ISB

VALVE NO.	LOCATION
1	AT ENGINE BLOCK
2	AT TRANSMISSION OIL COOLER

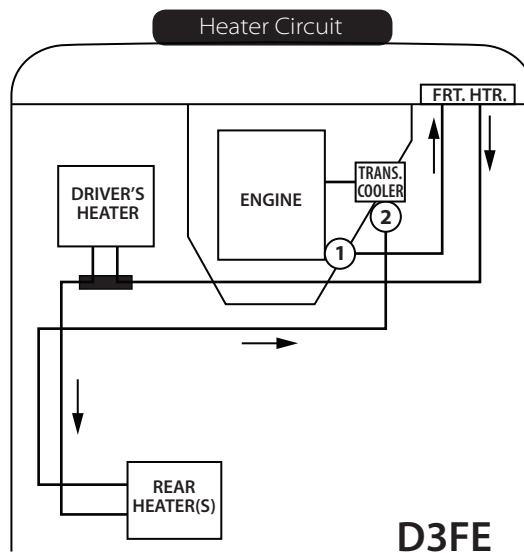



Although in most transportation operations, maintenance tasks will be performed by service technicians, familiarity with the basic technical data in this section will enhance the Driver's overall understanding of the vehicle, and may serve as a convenient reference for service technicians rendering roadside assistance. This section also contains general cleaning and care guidelines. For thorough service information and procedures, refer to the All American Service Manual.

Actual operating conditions must be considered and maintenance intervals adjusted accordingly. If at any time a system does not perform satisfactorily, corrective service should be performed at once. It is important that personnel attempting the repair or maintenance of this vehicle have access to, and a thorough knowledge of, the appropriate Blue Bird Service Manual.

ELECTRICAL

Interior Lights

<i>Lamp Description</i>	<i>Trade Name</i>	<i>Trade No.</i>	<i>Color</i>	<i>Bulb No.</i>
Dome	Weldon™	8020	(Standard)	922
Stepwell	Arrow™	35		67
	Soundoff™	SWLT		LED Non-Replaceable
Emergency Door Light	Soundoff™	140		LED Non-Replaceable
Switch Panel Pilots	Eaton™	NGR		53
Switch Panel Illumination		1314962		53

Exterior Lights

Directional	CRS™	103		1157
	Soundoff™	756		LED Non-Replaceable
Warning Light	Soundoff™	756IB		LED Non-Replaceable
Warning Light Halogen	CRS™	102		H3
Cluster and Marker	Weldon™	5210		LED Non-Replaceable
Side Directional	Soundoff™	MTY		LED Non-Replaceable
	CRS™	104		1157
Stop-Tail 7 inch	CRS™	103		1157
	Soundoff™	756		LED Non-Replaceable
Stop-Tail 4 inch	CRS™	103		1156
	Soundoff™	R4		LED Non-Replaceable
Backup	CRS™	103		1156
	Soundoff™	R4		LED Non-Replaceable
Tag	CRS™	104		168
	CRS™	104		LED Non-Replaceable
Destination Sign				89
School Bus Sign				TS93



Doran Warning Light Monitor

The Doran Monitor™ is a current sensing device. If current is flowing through one of the bus lamp circuits, the monitor senses it and illuminates the corresponding monitor light emitting diode (LED). When a lamp burns out, current flow through the circuit stops and the corresponding LED on the monitor does not illuminate, indicating the outside lamp is not functioning. The Doran™ Monitor is located in the bulkhead over the windshield and slightly to the left of the driver.

Warning lights are such an essential safety feature, it is important to know when they are not working properly. This is the function of the Doran monitor. Its display is a schematic of the lights as they appear outside the bus. It continuously monitors the current in each lamp. If current is flowing through a particular bus lamp circuit (i.e., the light is on), the monitor senses this and lights the corresponding monitor bulb. If the bus lamp burns out, current ceases and the corresponding monitor bulb goes out, indicating a fault. Once the defective lamp is replaced, and the warning lights are working normally again, this also should be shown by the monitor.

The Doran monitor is a reliable, long-life device, but as with most electrical instruments, it can be overheated and damaged if an overload occurs in a bus light. Such overloads can exist if a bus light circuit becomes shorted, forcing current through a coil in the monitor that exceeds the coil's rated capacity. Short circuits can occur if improper connections are made during installations, bus repairs, etc. If the monitor has an optional thermistor overload protection, the tail light circuits are overload-protected. (Thermistors are located on the bottom of the component side of the printed circuit board.)

If the Doran monitor is not working properly, see **Troubleshooting** for units equipped with incandescent lighting only. See **Calibration** for units equipped with LED lighting.

Troubleshooting

The Doran Warning Light Monitor™ does not display any indicator LEDs:

1. An overload situation has created an open circuit. Check the system fuses.
2. An overload or physical damage has burned or broken a conductor on the printed circuit board:
 - Extra lights have been added to the circuit; i.e., trailer lights, etc.:
 - Remove the extra lights from the circuit
 - Replace the damaged printed circuit board
 - Excessive vibration or abuse has resulted in a damaged monitor. Replace the printed circuit board

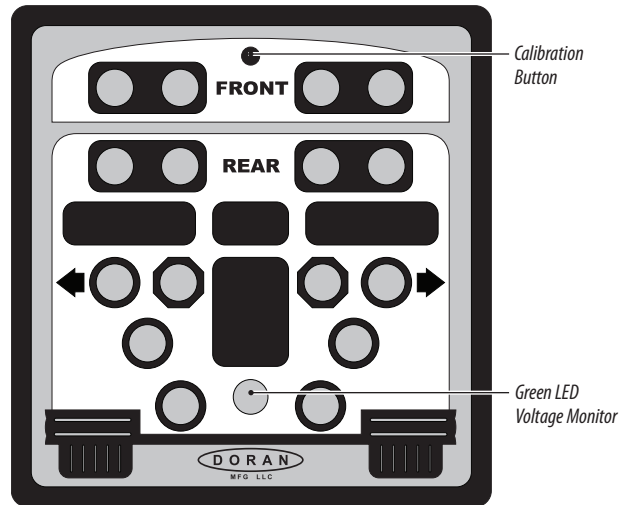

A particular LED on the Doran Warning Light Monitor™ does not display, but the bus running lights are operating properly:

1. There is an open coil in the monitor
 - The coil is burned due to an overload. Replace the coil kit.
 - A solder joint has weakened (a cold solder joint). Flow new solder on the connection.
 - The reed switch has failed. The reed has broken or the contacts have failed. Replace the reed switch kit.
 - The printed circuit board is broken or burned. Replace the printed circuit board.
 - There is an open in the LED circuit. Replace the LED.

A monitor LED indicator is on but, the bus running light indicated is not operating, or the bus running light switch is in the off position and the monitor indicates the running lights are operating:

- Replace the coil and reed switch kit.

Neither the bus running lights nor the Doran Warning Light Monitor™ operate properly:

1. The running light bulb may be burned out. Replace the light bulb.
2. The overload thermistor has protected the circuit from overload. Remove the overload condition.
 - A short
 - Incorrect light bulb/s
 - Extra lights; i.e., trailer lights, etc.

Calibration

To self calibrate the monitor, ALL monitored lights must be in working order. For faster calibration, the operator may turn on as many exterior lights as possible at the start of the procedure. The operator will be required to activate these lights during the calibration procedure. Operator may begin with the tail/head lights on, hazard lights (for the turn signals), and the amber warning lights flashing (door closed).

1. Turn on ignition and start engine – Engine is running to assure proper voltage for operation and calibration. The GREEN LED voltage indicator at the bottom center of the monitor MUST BE ILLUMINATED indicating the voltage is within limits for proper operation. Before beginning calibration, allow time for the voltage to stabilize to its normal running voltage. After cranking the engine the battery voltage may be lower than normal. Allow time for the battery to recharge.
2. When the ignition is turned on, all LED's on monitor will be enabled for a few seconds to verify that all LED's are working.
3. To enter the calibration mode, press and hold the calibrate button through the face plate hole for longer than two (2) seconds. This button/hole may be found located at the bottom left corner of the bus image on the monitor face plate. The first light to calibrate will begin flashing when the unit enters calibration mode. You may use an object such as an allen wrench or paper clip to activate the switch.

CAUTION Do not attempt to check a light emitting diode (LED) with an ohmmeter. Some digital volt meters (DVM) have a diode checking position, which is acceptable to test LEDs. Any repair of the Doran Warning Light Monitor™ should be referred to a qualified technician.



4. The unit will begin calibrating each light in a sequence. Each light tested must be active at the time of the calibration. As each light is calibrated, the matching monitor LED will flash. Operator shall activate (if not active) the bus light corresponding to the flashing LED. The sequence is as follows:
 - a. Left turn signal – switch on
 - b. Right turn signal – switch on
 - c. Stop lights (left, then right side 7" will flash) – press brake pedal
 - d. Tail light (left, then right side 4" will flash) – switch on (brakes off)
 - e. Backup lights – press brake/clutch and engage reverse
 - f. Each Amber warning light – switch on with door closed
 - g. Each Red warning light – open door
5. Calibrated lights are indicated by the corresponding LED staying illuminated on the monitor. The unit continues to loop through the sequence flashing the un-calibrated lights until all lights are calibrated.
6. When all LED's are illuminated, turn off ignition to complete the calibration.

Circuit Breakers

The electrical system is protected by fuses as standard, circuit breakers are optional. Circuit breakers or fuses are located in a side mounted electrical box below the driver's window. If a current overload or "short" should occur in any body circuit, it will trip the circuit breaker. If a short occurs and the circuit breaker breaks, the circuit breaker will reset when the element cools; usually in about 15 seconds. A short may be indicated by blinking lights or fluctuating gauges. The shorted circuit should be corrected immediately. Refer to body or chassis master wiring diagrams. A complete wiring diagram is available from Blue Bird Corporation Technical Publications.

To access the electrical panel, open the access door located outside the bus below the driver's window. A reference decal is provided on the inside of the access panel. Use of appropriate amperage circuit breakers is required.

ACCESSORIES AND ADDED COMPONENTS

When adding accessories and aftermarket components, it is important to consider the results very carefully.

- Does the component over burden the electrical system?
- Does the accessory interfere with any of the driver's controls?
- Does the accessory interfere with the driver's field of vision?
- Heavy components and accessories must be mounted near, or below, the floor line to avoid raising the vertical center of gravity.
- Will passenger safety and comfort be adversely affected?

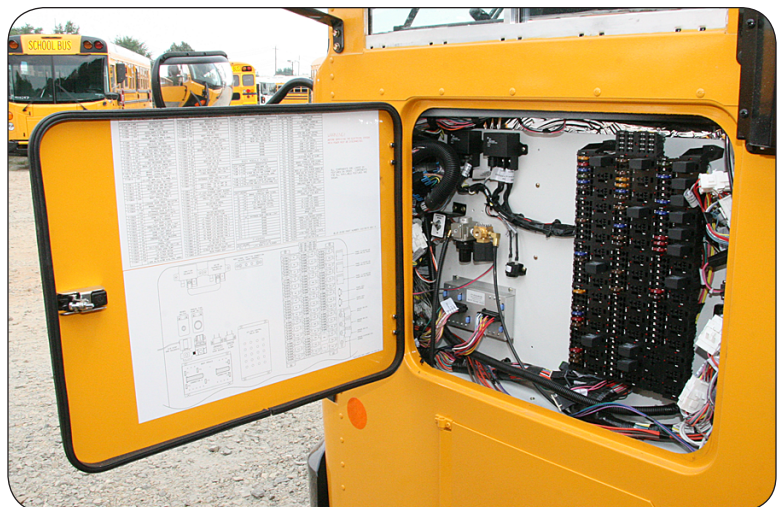

DOOR ADJUSTMENT & LUBRICATION

Maintenance procedures for entrance doors must be performed by qualified technicians at intervals of one month or 1,000 miles, whichever occurs first.

Continuing Maintenance Requirements

- Keep working parts of control tightened.
- Lubricate all working parts periodically, including hinges and overhead controls.
- Repair or replace worn seals.
- Maintain proper door opening and closing adjustment.

Outward Opening Door Adjustment

Outward Opening Doors are mounted in a prefabricated framework, which eliminates the effect of body construction variations on door and seal operation. Doors are suspended completely on sealed ball bearings located at the top corners of the framework, inside the body. The interlink connection between the doors is a single assembly with oppositely threaded, spherical bearing rod end connectors at each end, providing simple link length adjustment without disassembly. Loosen the lock nut, turn the tube, and retighten the nut when satisfactorily adjusted. The geometry of the mechanical link between the doors causes the rear door to close well ahead of the front door, so that the front nosing seal rubber always overlaps the rear. Oil impregnated bronze bearings in the lower corners of the framework serve as pivots (not supports). All controls and mechanisms and the complete lower step tread are sealed inside the bus and out of the weather when the door is closed.

Outward Opening (Air Powered) Adjustment

The pneumatic actuator is a cylinder connected to a lever on each door, located inside the header cover. An interconnecting link between the doors controls the operation sequence. A safety release valve is located over the door. Air switches inside the header cover operate Stepwell lights. A two way manually operated valve manages the driver's door control. Air pressure holds the door either open or closed, depending upon the position of that valve. The operation speed is adjustable by use of flow control valves located on the actuator.



Sliding Bolt Vandal Lock

Lubricate the sliding bolt mechanism of the Sliding Bolt Vandal Lock every six months or 6,000 miles (whichever occurs first). Use LPS-1 spray lubricant, or equivalent.

Security Lock Lubrication (Outward Opening Door)

If the Outward Opening Door Security Lock becomes difficult to operate, remove the access plate on the inner door panel and lubricate with No. 2 lithium grease. (Access plate shown removed in illustration.)

Lubricate security locks every six months or 6,000 miles, whichever occurs first. Using LPS-1 or Apply™ lubricant (or equivalent), spray into the bushing and shaft in the center at the base of the lock handle. Also spray lubricant into key lock mechanism. Rotate the lock handle to ensure smooth operation.

Manual Security Lock (interior)

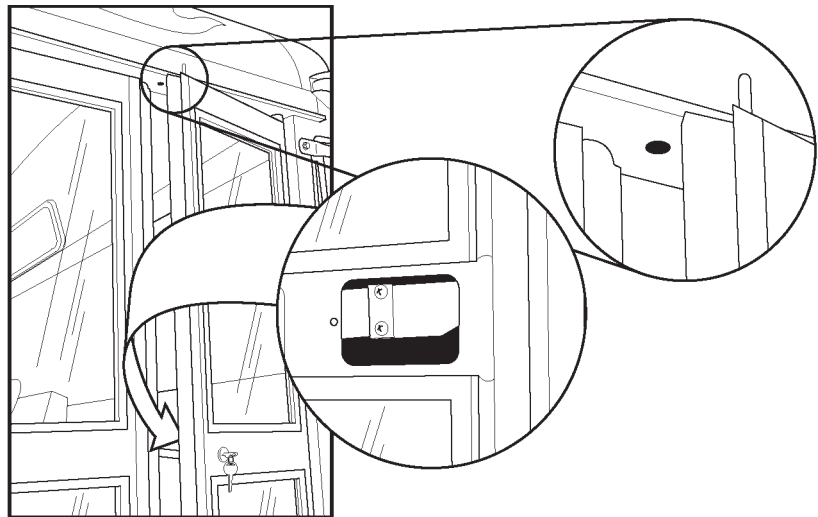

Access Doors

Periodic maintenance is necessary to prolong the life of access door latches, locks, and hinges. Each week, clean and inspect the door hinges and latch mechanisms. Clean with a nonabrasive degreaser or cleanser as required. Every three months, lubricate with either a graphite-type lubricant or a spray-type lubricant such as LPS. Following is a list of access doors for which these maintenance procedures are recommended:

- Battery Compartment Door
- Luggage Compartment Door
- Tire Compartment Door
- Fuel Fill Door
- Radiator Fill Door
- Side Electrical Panel Door
- Left and Right Hand Front Access Doors

Glove compartment and emergency equipment doors should be inspected on a daily basis. Open and close to ensure proper operation. If necessary, follow the same lubrication procedure as outlined above.

SEATING CARE

Seat Belt Inspection And Maintenance

Inspect seat belts and their attachments, at least weekly. Check seat belt buckles and adjustability to ensure proper operation. If necessary, lubricate the buckle with a graphite lubricant. When a buckle is found to be inoperable, replace it immediately. If there are any defects in the webbing (i.e., torn or frayed), the seat belt must be replaced immediately to ensure passenger safety. Hand wash webbing with warm water and mild soap. Rinse thoroughly and dry in the shade. Do not bleach or re-dye, because such processing may severely weaken the assembly.

WARNING Do not bleach or dye the webbing. Such processing may severely weaken the assembly.

Seat Inspection And Maintenance

Blue Bird seats are built to meet Federal Motor Vehicle Safety Standards. In order to provide a greater margin of safety during passenger transportation, follow these guidelines:

- Inspect and, if necessary, tighten seat leg and wall side mounting bolts every 90 days.
- Inspect and, if necessary, tighten cushion attachments weekly.
- Inspect upholstery for cuts and tears every 90 days. If upholstery is torn, remove it by taking out the staples at the bottom front of seat back or bottom of cushion and pulling the cover away. For installation of new cover, reverse this procedure.
- School bus seats are equipped with a special foam back pad. If the pad becomes damaged, it should be replaced with an approved part. Aftermarket suppliers should be checked for compliance with Federal standards.

DRIVER'S SEAT LUBRICATION

Moving parts of the driver's seat require lubrication for ease of operation, as well as longevity of the seat and prevention of excessive wear.

Currently available is white lithium-based grease in an aerosol can. It gives excellent coverage when carefully directed into moving part joints. The very light coating of lubrication provided by aerosol-carried solvent-type solution works very well for penetrating into a joint and cleaning away dirt, but it should only be depended on for lubrication if it is applied frequently. A common 10W30 or 10W40 motor oil will provide good lubrication.

Remember that all moving part joints, tilt pivots, slide forward/back adjustment, and vertical motion pivots (four in all) require lubrication. This should be done every six months or 6,000 miles, whichever occurs first. The use of lithium-based grease in aerosol form is recommended.



SEAT CARE AND CLEANING

It is imperative that the interior of the bus be kept clean; seats are an important part of this maintenance. Regular cleaning and care will prolong the life of the seats and improve the general appearance of the bus.

Everyday dirt and soil. Most everyday soil and dirt may be removed with a soap and water solution. If the stain is persistent, a stiff bristle brush may be used. Fabric covered seats should be rinsed with clean water after the stain is removed.

Paint, tar, and asphalt. Remove the stain immediately using a damp cloth and kerosene. Rub gently, using small strokes. Rinse thoroughly. This type of stain may become permanent if not cleaned immediately.

Nail polish and lacquer based stains. Soak up as much as possible with dry cloth immediately. Any remaining stain may be removed with a non-flammable cleaning fluid such as "Tuff Stuff™" or "Armor All™" cleanser. Rinse thoroughly with clean water.

Gum, grease, and shoe polish. Remove as much as possible immediately. If left for any length of time, shoe polish will stain permanently. Clean any remaining stain with "Tuff Stuff™" or "Armor All™" cleanser.

Ink. Remove stain immediately using a damp cloth and alcohol.

SEAT CUSHION REMOVAL AND INSTALLATION—DOT SEATS & SEAT BELT SEATS

WARNING *If seat cushions are removed for maintenance, they must be reinstalled using the following instructions. Failure to comply with these instructions could result in injury from unattached seat cushions in the event of an accident.*

1. To remove the seat cushion. Loosen and remove two Torx screws from the flanges at the front of the seat frame.
2. Lift the forward edge of the cushion 2 to 3 inches (5 to 8 cm) and pull forward.
3. To reinstall the seat cushion reverse the above procedure.

TRACK MOUNTED PASSENGER SEATS

If your bus is equipped with track mounted passenger seats and you relocate the seats or remove them to accommodate wheelchairs, you must follow rules of spacing and placement to comply with Federal Motor Vehicle Safety Standard 222 "School Bus Passenger Seating and Crash Protection" and Federal Motor Vehicle Safety Standard 217 "Bus Window Retention and Release". A decal printed with these rules (as shown below) is installed on the interior body panel above the windshield.

WARNING *The federal rules governing passenger seating, spacing, and placement are explicit. When the seats are moved, the entity moving or re-arranging the seating assumes responsibility for compliance with FMVSS 222 "School Bus Passenger Seating and Crash Protection" and FMVSS 217, "Bus Window Retention and Release".*

All passenger seats must have a seat or barrier in front of it to provide compartmentalization required by Federal Motor Vehicle Safety Standards. As you reconfigure your bus, you may need additional barriers, which are available from Blue Bird Corporation Part Sales.

Blue Bird Track Mounted Seats

01943760 BB

FEDERAL STANDARDS REQUIRE THAT ALL PASSENGER SEATS MUST BE LOCATED REARWARD OF A SEAT OR BARRIER OF AT LEAST THE SAME WIDTH. SEATS MUST BE INSTALLED BETWEEN MINIMUM AND MAXIMUM SPACING AS LISTED BELOW IN ORDER TO MEET FMVSS 222 REQUIREMENTS.

<p style="font-size: x-small;">A CHILD RESTRAINT DECAL MUST BE LOCATED ADJACENT TO ALL LATCH SEATS</p> <p style="text-align: center;">SEAT BARRIER</p> <p style="text-align: center; font-size: x-small;">27.00 MIN. 11.00 MIN. 31.00 MAX. 16.00 MAX.</p> <p style="text-align: center;">SEAT SPACING MEASURED AT AISLE</p>	<p style="text-align: center; font-size: x-small;">12 (MIN)</p> <p style="text-align: center; font-size: x-small;">24 (MIN)</p> <p style="font-size: x-small;">REAR EMERGENCY DOOR CLEARANCE: A CLEAR ACCESS AREA OF SIZE SHOWN WITH HEIGHT OF 45 IN. IS REQUIRED TO MEET CMVSS 217 OR FMVSS 217.</p>	<p style="text-align: center; font-size: x-small;">12.00 (MIN)</p> <p style="text-align: center;">SIDE EMERGENCY DOOR CLEAR AISLE</p>	<p style="text-align: center; font-size: x-small;">2.00 (MIN)</p> <p style="text-align: center; font-size: x-small;">FOR 74 HEADROOM ONLY EMERGENCY EXIT RELEASE CLEARANCE</p>
--	---	---	--



C E White, Child Restraint, Track Mounted Seats

00062317 CEW CR

FEDERAL STANDARDS REQUIRE THAT ALL PASSENGER SEATS MUST BE LOCATED REARWARD OF A SEAT OR BARRIER OF AT LEAST THE SAME WIDTH. SEATS MUST BE INSTALLED BETWEEN MINIMUM AND MAXIMUM SPACING AS LISTED BELOW IN ORDER TO MEET FMVSS 222 REQUIREMENTS.

<p>BLUE BIRD TRACK MOUNTED SEAT CEW CHILD RESTRAINT SEAT A CHILD RESTRAINT DECAL MUST BE LOCATED ADJACENT TO ALL LATCH SEATS</p> <p>32.00 (MIN) 27.00 (MAX)</p> <p>33.00 (MIN) 30.00 (MAX)</p> <p>32.00 (MIN) 29.00 (MAX)</p>	<p>CEW CHILD RESTRAINT SEAT BARRIER</p> <p>16.00 (MIN) 14.00 (MAX)</p>	<p>12 (MIN) 24 (MIN)</p> <p>REAR EMERGENCY DOOR CLEARANCE: A CLEAR ACCESS AREA OF SIZE SHOWN WITH HEIGHT OF 45 IN. IS REQUIRED TO MEET CMVSS 217 OR FMVSS 217.</p>	<p>12.00 (MIN)</p> <p>SIDE EMERGENCY DOOR CLEAR AISLE</p>
---	--	--	---

C E White Student Safety Seat, and C E White Student Safety Seat Child Restraint, Track Mounted Seats

00062639 CEW SSS_SSSCR

FEDERAL STANDARDS REQUIRE THAT ALL PASSENGER SEATS MUST BE LOCATED REARWARD OF A SEAT OR BARRIER OF AT LEAST THE SAME WIDTH. SEATS MUST BE INSTALLED BETWEEN MINIMUM AND MAXIMUM SPACING AS LISTED BELOW IN ORDER TO MEET FMVSS 222 REQUIREMENTS.

<p>A CHILD RESTRAINT DECAL MUST BE LOCATED ADJACENT TO ALL LATCH SEATS</p> <p>SEAT BARRIER</p> <p>29.00 MIN. 33.00 MAX.</p> <p>14.00 MIN. 16.00 MAX.</p> <p>SEAT SPACING MEASURED AT AISLE</p>	<p>12 (MIN) 24 (MIN)</p> <p>REAR EMERGENCY DOOR CLEARANCE: A CLEAR ACCESS AREA OF SIZE SHOWN WITH HEIGHT OF 45 IN. IS REQUIRED TO MEET CMVSS 217 OR FMVSS 217.</p>	<p>12.00 (MIN)</p> <p>SIDE EMERGENCY DOOR CLEAR AISLE</p>
--	--	---

SIGNS & SIGNALS

Stop Arms

Stop arms are required on Blue Bird All American school buses by, and in accordance with, Federal Motor Vehicle Safety Standard 131. Stop arm assemblies are purchased as a kit to meet state requirements. The stop arm is located on the left-hand side of the body under the driver's window. A manual switch on the switch panel most commonly operates stop arms.

For pneumatically operated stop arms, the manual switch activates an electric solenoid valve controlling the flow of air. Optionally, the solenoid valve may be activated by the warning lamp system. This system is operated by the air system on the chassis. No special preventive maintenance procedures are required with these systems; however, the air pressure may occasionally require adjustment to ensure proper opening and closing of the stop arm. The air regulator is accessible through the outside electrical panel door under the driver's window. To regulate the air pressure, remove the wire retaining clip below the regulator knob and pull the red lock ring. Turn the knob counterclockwise to decrease the pressure, and then slowly increase the pressure (turn knob clockwise) until the stop arm hinge is extended to approximately 90°. Lock the knob into position by pushing in the red lock ring and installing the wire retaining clip.

Electrically operated stop arms may be activated by a manual switch or, optionally, by the warning lamp system.

The "STOP" sign must extend, and if equipped with lights, the lights must be operating any time the red lights of the warning light system are flashing. For state-designed warning light/stop arm systems which allow the stop arm to withdraw while warning lights are operating, an audible alarm sounds to alert the driver of the condition.

Monthly Maintenance

- Oil the dual action breakaway hinge at its pivot points with a high performance, penetrating lubricant. Tri-Flow™ (duPont™) with Teflon™ is recommended.
- Check that the breakaway portion of hinge is freely movable.
- Check that fasteners are secure.

Quarterly Maintenance

- Perform the "Monthly" procedures, above.
- Remove front and rear covers of base and check that fasteners are secure.

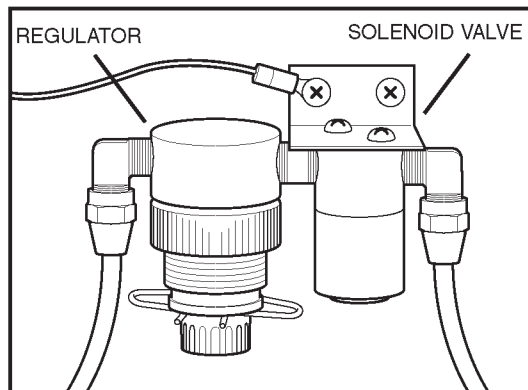



Destination Signs

Hinged Sign Front

Mounted on the outside of the front roof cap, with internal control for changing the display. Periodically lubricate hinges and lever assembly with lightweight lubricating oil.

Hinged Sign Rear

Mounted on the outside of the rear roof cap, manually changed from outside. Periodically lubricate hinges with lightweight lubricating oil.

One Station Lighted Curtain

Replace bulbs as needed. Because of vibration, the curtain can loosen. To tighten the curtain, loosen the bolts, pull the curtain taught and then tighten the bolts.

Roller Destination Sign with Lighted Curtain

Replace bulbs as needed. Curtain may occasionally require same adjustment as One Station Sign. Periodically lubricate the roller gears with light grease, such as White Lube™. Lubricate the hinges on the access door with lightweight lubricating oil. To change the display, turn the crank located on the front, upper, inner panel above the windshield.

Two Station Sign

Front lighted with lettering on both sides. Lubricate the interior door hinge on the front, upper, inner panel with lightweight lubricating oil.

Lighted "School Bus" Sign

Back lighted yellow Plexiglas™ sign. Replace bulbs as needed. Lubricate the interior door hinge on the front, upper, inner panel with lightweight lubricating oil.

ENGINE & RUNNING GEAR

Air Intake System Inspection

Intake air must be filtered to prevent dirt and debris from entering the engine and causing premature wear. Air intake piping should be checked daily, as should charge-air piping and engine air cleaner service indicator, if equipped. Repair any leaks in the system before operating the bus. Never operate the engine without an air cleaner or with disconnected or loose piping.

Intake Air Restriction Indicator

Some engines are equipped with a gauge which displays the difference in air pressure before and after the air cleaner. As the air cleaner element becomes dirty, the pressure differential rises. If your engine is equipped with a different type of service indicator, follow the manufacturer's recommendations to service the indicator.

CAUTION *Leaks in the intake system will prevent the Air Restriction Indicator from reading accurately. Always check the piping for leaks, especially between the indicator and the engine intake.*

Maximum intake restriction (clean air filter element): 10.0 inches water (254 mm)

Maximum intake restriction (dirty air filter element): 25.0 inches water (635 mm)

Cummins. Replace the engine air cleaner every 12 months, or when the air cleaner service indicator shows restriction of 25 inches of water. Do not rely completely on the restriction indicator. A leak in the system will prevent the restriction indicator from operating properly. Always look at the piping to ensure there are no leaks.

Air Intake Piping

Inspect the intake piping daily for wear points and damage to piping, loose clamps, or punctures that can cause damage to the engine. Replace damaged pipes, and tighten loose clamps; replace if necessary, to prevent the air system from leaking. Check for corrosion under the clamps and hoses of the intake system piping. Corrosion can allow corrosive products and dirt to enter the intake system. Disassemble and clean as required.

Charge Air Piping

Inspect the charge air piping and hoses daily for holes, cracks, or loose connections. Tighten the hose clamps as necessary.

Charge-Air Cooler (CAC) Maintenance

Check this system every 3 months or 7,500 miles. Inspect the charge-air cooler (CAC) for dirt and debris blocking the fins. Check for cracks, holes, or other damage. If damage is found, refer to your Blue Bird Dealer.



Air Restriction Indicator behind Front Left Access Panel



Engine Cooling System

In today's modern engine designs, accurate maintenance of the cooling system is critically important to engine life. Simply maintaining coolant level and performing occasional coolant changes does not adequately ensure that the cooling system is healthy. The chemical balance of engine coolant must always be correct. This requires diligent adherence to the engine manufacturer's coolant specifications, maintenance schedules, and procedures. Accurate coolant system maintenance records should be kept.

The engine coolant level in the reservoir should be checked daily as a part of routine pre-trip inspection. But whenever the coolant level is low, it must be replenished with only pre-mixed coolant of the same type and brand installed. Never top off coolant with plain water.

Careful pre-trip inspection and a program of routine maintenance checks of the condition of the cooling system by service technicians should ensure against enroute emergencies such as worn hoses or loose clamps resulting in coolant loss. In the case of such an emergency, however, if anything other than original premixed coolant is added in order to allow the bus to proceed to a service facility, the coolant system must be completely drained, flushed, and properly refilled with approved coolant before being returned to routine service. Any enroute event requiring topping off of the coolant should be reported to service personnel responsible for maintenance of the bus.

WARNING *Exercise extreme care when removing the cap from the engine coolant reservoir. Always allow time for the engine to cool before removing the cap. The pressurized coolant may be very hot and can spray out, causing serious burn injuries.*

Coolant Types

Engine coolant is generically divided between two types; "standard" and "long-life" (or "extended-life"). Extended-life coolants generally allow longer intervals between coolant changes (sometimes requiring additives to be added near the midpoint of their service life, and/or for special testing to be performed at certain intervals). Engine manufacturers, however, differ somewhat in regards to specifications for coolants which they recognize as "long-life" when used in their respective engines.

Blue Bird buses are delivered from the factory with one of two types of coolant. The standard coolant is Fleetguard Fleetcool EX 50/50 premix, which is red in color. This coolant is considered standard life when installed in Cummins engines.

Cummins equipped buses purchased with an extended life coolant option have been filled with Fleetguard ES Compleat OAT 60/40 premix, which is red in color.

Blue Bird installs a decal on or near the deaeration tank filler which state the type of coolant installed at the factory. The decal states the approved premixed coolant and coolant manufacturer's part number for one gallon quantities. The decal also lists the manufacturer's part number for the concentrate which is approved for mixing with the premix for stronger glycol concentration. Another decal near the fill neck indicates warnings for the service technician.

CAUTION *When replenishing or replacing coolant, only use coolant of the same type already installed. Never mix coolants of different color, type, or brand. Plain water is corrosive at engine operating temperatures. Never add plain water to the system. When using concentrated coolant to raise the glycol concentration for extreme temperature environments, Blue Bird recommends only mixing the concentrate with pre-mixed coolant of the same type; not mixing with water.*

Coolant Testing and Replacement

Each engine manufacturer has its own specific requirements for coolant testing and maintenance. Therefore, refer to the engine Operator's Manual for your bus and follow the engine manufacturer's maintenance specifications.

Blue Bird recommends strictly abiding by the engine manufacturer's testing and maintenance schedules and draining, flushing, refilling procedures to maintain compliance with the engine warranty requirements. Blue Bird also recommends that you maintain accurate vehicle-specific service records of all coolant system maintenance procedures performed.

The cost of the testing is the owner's responsibility as part of the engine manufacturer's requirements for testing and maintaining the engine and coolant.

For Cummins engines using Fleetguard Fleetcool EX coolant, send coolant samples to Fleetguard for Monitor C testing, as specified in the Cummins Operator's Manual. Label sample as Conventional coolant.

For Cummins engines using Fleetguard ES Compleat OAT extended life coolant, send coolant samples to Fleetguard for Monitor C testing, as specified in the Cummins Operator's Manual. Label sample as Extended-Life coolant.

CAUTION *Never mix coolant types.*

Routine coolant addition (top-off) must match the installed coolant type and brand. Do not mix coolants of different colors, types, or brands in the same engine.

CAUTION *Always mix concentrate with premix coolant, not water.*

If concentrated coolant is added in order to raise the glycol ratio, use only the concentrate version of the same premix coolant type and brand as installed. Do not mix the concentrate with water. Instead mix the concentrate with the premix version of the same coolant.

CAUTION *Only add tap water in emergency situations.*

A regularly-scheduled bus inspection and maintenance program should be followed to prevent coolant losses due to damaged or worn hoses, loose clamps, etc.

If coolant is lost while the bus is in use, and roadside emergency measures are called for, replenish the coolant with the same premix type and brand if possible. If the proper coolant is not available, and water must be used, use only de-ionized water if possible. Ordinary tap water should only be used if proper coolant or de-ionized water are not available.



Whenever tap water alone has been added, the bus should be taken to a service facility and the entire cooling system should be completely drained, flushed, and refilled with premix coolant.

Blue Bird buses equipped with Cummins engines may also be equipped with an optional coolant filter. The coolant filter should be replaced every 6 months or 6,000 miles; whichever occurs first. The coolant filter element installed at the Blue Bird factory is compatible with all of the above-described coolants:

BLUE BIRD NUMBER 00064641

See your Blue Bird *D3FE Service Manual* for complete detailed *Coolant Fill* procedures.

Shutters

The optional radiator shutters assist in maintaining a constant engine temperature by limiting the air flow through the radiator. The shutter blades are powered open/closed by either engine oil pressure or by pressure from the air system on the vehicle by means of an electric solenoid. The solenoid is controlled by the Blue Bird "Corporate" Instrument Cluster based on engine ECM broadcast values of coolant and intake manifold temperatures. Shutters should be inspected regularly and kept free of obstructing debris. The pivot points of the louvers and their linkages should be lubricated annually with an anti-seize compound, such as BB # 2550549. The shutters must be cleaned and lubricated yearly. More frequent lubrication, especially during the winter months, is required on buses operating in climates that use salt and other corrosive elements on the roadways.

Transmission

Transmission Breather

The transmission has a self-contained breather at the top left rear of the transmission main housing. The breather provides a passage for normal expansion and contraction of air and fluid within the transmission. Be careful to avoid plugging this breather with paint, undercoating, or any other material. A small amount of oil mist comes out of the breather during normal operation. If an excessive amount of oil is found in this area, the cause should be investigated.

CAUTION *When cleaning the transmission, do not spray steam, water, or cleaning solution directly at the breather. This may contaminate the transmission fluid.*

Transmission Fluid Level

Transmission fluid cools, lubricates, and transmits hydraulic power. Always maintain proper fluid level. If fluid level is too low, the torque converter and clutches do not receive an adequate supply of fluid and the transmission will overheat. If the level is too high, the fluid aerates, causing the transmission to shift erratically and overheat. Fluid may be expelled through the breather or dipstick tube when the fluid level is too high. Please see your Allison Transmission Operator's Manual for information on how to check fluid levels at both cold and hot engine temperatures. Allison recommends the use of Transynd Synthetic transmission fluid.

Transmission Fluid And Filter Changes

Please see your Allison Transmission Operator's Manual for procedures to change transmission fluid and filters, and the intervals at which these should be done.

Rear Axle

All drive axles have a vent on the top of the axle housing that allows the axle to breathe as the axle temperature changes. The vent must remain open to prevent seal failures. It is normal for the vent to ooze a small amount of lubricant.

Hydraulic Brakes

The brakes self-adjust for lining wear. Brake fluid in the reservoir, located behind the driver's side front access panel, must be maintained to the correct level. As the brake linings wear, fluid level in the reservoir will go down, displacing the lining loss.

CAUTION *Use only DOT 3 or DOT 4 brake fluid in this reservoir.*

WARNING *Put only brake fluid in the brake fluid reservoir and only power steering fluid in the power steering system. Mixing fluids or failure to use the proper fluid, could result in loss of braking or steering.*



WINDSHIELD WIPERS

Washer Solution Reservoir

Periodically check the windshield washer solution reservoir, located behind the driver's side front access panel. Be sure there is an adequate supply of fluid at all times. The solution used is a 50/50 mixture of methanol and water.

Wiper Assembly Replacement

To replace wiper assembly, loosen lock nut, remove screw, and pull wiper assembly loose from wiper arm. Replace the wiper assembly and use original screw and lock nut. Tighten lock nut securely, but do not tighten enough to compress the saddle. Blade must be free to move on the axis (machine screw) and within the saddle. Threading the lock nut until flush with the machine screw end will give a secure and serviceable installation.

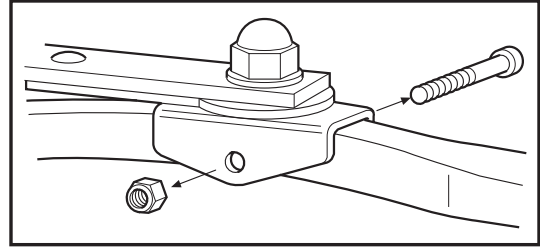

HEATER CARE

The front heater can be accessed from the curbside access panel outside the bus at the front, and from the inside, on the dash near the stepwell. To access the heater core and interior filter, remove the interior heater access panel shown. Access the outside filter behind the front curbside access panel.

Annual Maintenance

Maintenance intervals for filters and cores are minimum. In extreme dusty and dirty environments the maintenance must be performed more often to insure proper air flow. Maintenance and inspection of all the heater cores and filters and/or screens in the heater system is critical to prevent loss of efficiency, function and/or premature heater motor failure. Replace parts with OEM parts purchased from your Blue Bird Dealer.

Filter

The main heater core is protected by an air filter, which prevents dirt and dust from collecting on the heat exchange surfaces and thereby lowering heater efficiency. The driver's underseat heater has a screen. Care should be taken to keep screens and filters clean. A dirty filter restricts airflow and reduces heater output. To clean or replace the filter, remove the filter access panel. The filters and screen are washable. If a filter cannot be washed or is damaged, it **MUST** be replaced immediately. If the screen cannot be cleaned a new screen **MUST** be installed immediately. The filters must be inspected, cleaned or replaced every 12 months or 12,000 miles.

Hoses

Check all water hoses for kinks that can prevent water flow or chafing that can cause failure. Look and feel for hardening of rubber or cracks that result from aging. Hoses should be replaced when cracks first appear. Hoses under the bus and in the engine area will deteriorate faster than those inside the bus. Exposed hoses should be checked more frequently.

Cores

The heater will be most efficient when the core is clean. The core should be cleaned carefully with compressed dry air or vacuum and a soft bristle brush. Damaged fins should be straightened with a fin comb to prevent airflow restrictions. The forward heater core can be accessed through the right front inside access panel. Under seat heaters are accessed by removing the passenger seat cushions that are over them. Heater cores must be inspected and cleaned every 12 months or 12,000 miles.

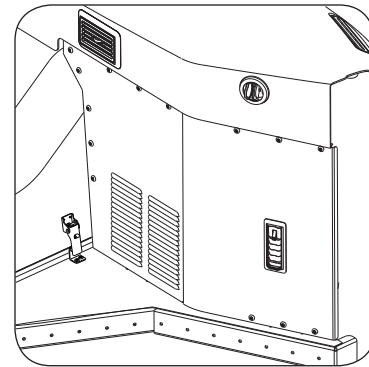

*Heater Filter Access Panel
above Stepwell*



Motors, Switches, Blowers, and Fans

Maintenance free motors are used and do not require lubrication or cleaning over their operating life. However, excessive vibration caused by damaged blower wheels or fans can cause motor damage. Inspect wheels and fans for obstruction or damage by running each fan individually, listening and feeling for irregularities. Replace damaged wheels or fans to prevent damage to parts, fasteners, and motors.

Switches are also maintenance free; however, loose wiring connections to switches or motors can cause excessive resistance and overheating damage. Wires to switches can be checked or repaired by removing the switch mounting panel next to the driver's seat.

Panels and Housings

Fasteners should be checked and tightened as necessary. A loose screw may allow a panel to vibrate, resulting in excessive noise, more loose screws, and/or metal fatigue.

Cleaning Auxiliary Fans

Auxiliary fan motor bearings are lifetime-lubricated, and do not require maintenance. Clean the blade and guard occasionally, with a soft bristle brush and a vacuum cleaner or compressed air, to help maintain efficiency. As with any other fan, if the blade is damaged or unbalanced, vibration damage can occur to the motor or surrounding components. If this is the case, the blade should be replaced immediately.

WARNING Do not operate a fan without the fan guard properly installed.

Procedure:

1. Remove the front half of the fan guard by gently separating the plastic tabs with a screwdriver or other hard instrument. Be careful not to damage the tabs, as these connect the front half of the fan guard to the rear half.
2. To remove the fan blade, use a 3/32-inch Allen wrench in the setscrew located directly behind the fan. This should loosen the fan blade for removal.
3. The rear half of the fan guard can also be removed if necessary. After pulling away the fan, remove the two nuts and washers on either side of the center point and lift off the rear piece.

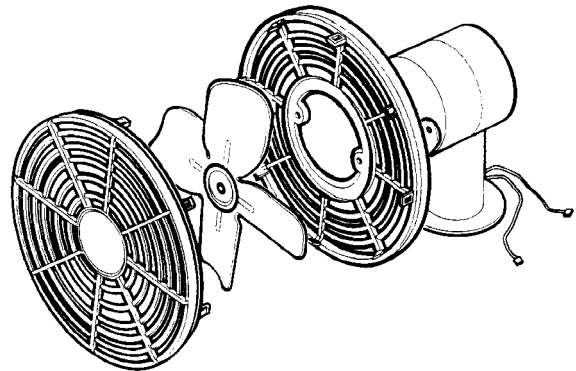

CLEANING

Exterior Cleaning

Before cleaning and waxing your bus a few basic rules should be followed:

- Start your project with the bus out of direct sunlight.
- Make sure the paint is not warm to the touch before applying any cleaning product or wax.
- Spray your bus with ample amounts of water before washing. Use the water to spray off dirt and other contaminants that will scratch the surface.
- Wash and rinse in sections so the wash soap doesn't dry before being rinsed off.
- Drying your bus after washing is necessary to prevent water spots – mineral deposits that etch the outline of a drop of water into your vehicle's paint.
- Read the manufacturer's directions on all products used prior to use.

Wash

In order to preserve your vehicle's finish, Blue Bird requires protection of the finish by washing a minimum once every 3 months.

- Wash the vehicle in lukewarm or cold water.
- Use a lamb's-wool or paint-safe microfiber washing mitt to prevent scratching the surface.
- Do not use hot water or wash in the direct rays of the sun.
- Do not use strong soap or chemical detergents.

Only cleaners with an HMIS rating of 1,0,0,0 or less should be used to clean the buses. This HMIS rating is available on all product MSDS.

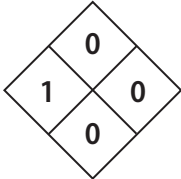
<p>Hazard Rating (NFPA/HMIS)</p> <p>Health = 1 Reactivity = 0</p> <p>Fire = 0 Special = 0</p>		<p>Rating Scale</p> <p>0 = Minimum 1 = Slight</p> <p>2 = Moderate 3 = Serious</p> <p>4 = Severe</p>
--	---	--

To wash units, Blue Bird Corporation recommends Bird Bath™ Bus Wash & Wax Concentrate, available from authorized Blue Bird Dealers. Bus Wash & Wax is a concentrated vehicle wash (rated triple-zero) that is recommended to be mixed at up to a 20/1 ratio for new and reconditioned buses.

CAUTION *Pressure washing may cause damage to finish. Pre-test pressure washer on a similar surface before applying pressure and chemicals to your vehicle. Pressure washers that re-circulate should filter the water to remove abrasive grit.*



Magnesium chloride, calcium chloride and other salts, ice melting agents, road oil and tar, tree sap, bird droppings, chemicals from industrial chimneys, and other foreign matter may damage vehicle finishes if allowed to remain on painted surfaces. Prompt washing may not completely remove all of these deposits. Additional cleaners may be needed. When using chemical cleaners developed for this purpose, be certain they are safe for use on painted surfaces.

Wax

Wax your bus a minimum of once a year with a nonabrasive wax. This is required to remove accumulated residue and eliminate any weathered appearance. It is essential that units are not waxed in direct sunlight.

Products labeled cleaner wax or polish should not be used as they are somewhat abrasive and can actually remove some paint from the surface of the vehicle. Care should be taken when choosing a wax to make sure that it does not contain abrasive materials i.e.; calcium carbonate, pumice, plastic beads, etc.

- Before waxing, thoroughly wash and dry the bus.
- Never wash or wax a bus in direct sunlight or if the paint is hot to the touch.

The sun can soften the paint and make it more susceptible to scratching.

- Use a lamb's-wool mitt for washing and soft cotton rags or microfiber towels for waxing. Do not use rags for waxing; they can trap dirt and scratch the finish. Synthetic fabrics and brushes can also scratch the finish.
- Wash and wax in small sections. This saves time and if the wax stays on too long, it can be difficult to remove.

Bus Downtime Treatment

During periods of bus downtime, Blue Bird Corporation recommends the application of Bird Bath™ Bus Guard Protectant available from Blue Bird authorized dealers to protect exterior surfaces. Bus Guard is a triple-zero product that, when properly applied, protects against harmful UV rays and other damaging environmental conditions. For sufficient protection, see product instructions for the proper application requirement.

Owners should refer to the limited warranty statement supplied with the vehicle regarding their responsibilities for care and maintenance of the vehicle during the warranty period.

Approved Waxes

- Meguiars Gold Class Liquid Wax
- Meguiars NXT Generation® Tech Wax® 2.0 Paste or Liquid
- Black Magic Wet Shine Liquid Wax
- Turtle Wax Carnauba Car Wax T-6
- Turtle Wax 1 Step Wax & Dry T-9
- Nu Finish NFP-80

Floor Cleaning

Regular cleaning and care will prolong the life of floor covering and improve the general appearance. Floor coverings should be swept daily and mopped weekly with a mild detergent and water. Do not use floor sweeping compounds. Be sure to remove dirt, pencils, paper, and any other debris that may cause the emergency door to seal improperly. Do not use harsh detergents or excessive amounts of water. Do not use a water hose to wash out the bus. Deterioration and damage to the wood floor could occur.

CAUTION *Petroleum products, such as oil and grease, quickly deteriorate the floor covering. These types of products should be removed from the surface as soon as possible. Continuous care must be exercised in the stepwell area, where foreign objects can create a safety hazard. The accumulation of dirt and foreign material in the stepwell area creates a hazard for passengers and could prevent the doors from operating properly. Ensure that screws for floor trims and aisle trims are seated tightly.*



MAINTENANCE SCHEDULE

Maintenance Task Schedule, D3FE

Ensure that the Safety Information, warnings and instructions are read and understood before operation or maintenance procedures are performed. Use whichever interval listed (time, mileage, engine hours) occurs first. Engines operated in severe operating conditions may require more frequent maintenance. See engine manufacturer's specifications for more information.

As Specified by Engine Manufacturer

Cooling System

Replace Coolant	See your Engine Operator's Manual. Use only premixed coolant(s) approved by the engine manufacturer. Never mix different types or brands of coolant.
-----------------	--

Engine

Replace Oil & Filter	See Engine operators manual for oil and filter specifications and maintenance interval.
Adjust Valves	See Engine manufacturer's Service Manual for interval.

As Specified by Transmission Manufacturer

Transmission

Adjust Transmission Shift Cable	See Transmission Chapter.
---------------------------------	---------------------------

First 100 Miles Then Every 12,000 Miles

Tires & Wheels

Inspect & Tighten Lug Nuts	Torque to 450-500 ft lb with calibrated torque wrench. Do not over-tighten. Do not lubricate nuts or studs. Operating conditions may require more frequent checks.
----------------------------	--

First 1000 Miles Then Every 3 Months or 6000 Miles

Frame

Inspect & Tighten Body Tie Downs Body Tie Down Clamps	Inspect for missing, damaged rubber pads. Tighten clamps to 37-41 ft lb.
Inspect & Tighten Body Tie Downs Rear Tie Down Bolts	Inspect for missing, damaged rubber pads. Tighten clamps to 37-41 ft lb.
Inspect Front Rubber Isolators	Replace any worn isolators. Tighten bolts to 52-56 ft lb.

First 1000 Miles Then Every 6 Months or 6000 Miles

Axle & Suspension, Rear

Inspect Comfort Air Suspension Ride Height	Shock length, eye-to-eye: 22.68" +/- 0.25"
--	--

First 1000 Miles Then Every 12 Months or 12,000 Miles

Heaters & Defrosters

Inspect Front Heater Hoses & Clamps

Inspect for evidence of leaks or deterioration. Replace with proper parts.

First 5000 Miles Then Every 12 Months or 24,000 Miles

Transmission

Replace Transmission Sump Filter

First 5000 Miles Then Every 24 Months or 24,000 Miles

Transmission

Replace Transmission Main Fluid Filter

First 11,000 Miles Then Every 3 Months or 5000 Miles or 250 Engine Hours

Engine

Inspect All Belts

Inspect condition and tension of belts.

First 11,000 Miles Then Every 6 Months or 5000 Miles

Cooling System

Inspect Charge Air Cooler

Inspect for clogging debris.

First Month Then Every 3 Months or 3000 Miles

Cooling System

Inspect & Tighten Hose Clamps

Tighten radiator hose clamps to 90 in lb. Tighten heater hose clamps to 45 in lb.



Every Day

Doors

Test Wheelchair Lift	Follow the manufacturers recommendations.
----------------------	---

Emergency Equipment

Inspect Fire Extinguisher Charge	Ensure that Extinguisher Charge is not expired.
----------------------------------	---

Inspect Fire Extinguisher Mounting Bracket	Ensure that Extinguisher bracket is secure and operates correctly.
--	--

Inspect First Aid Kit Contents	Ensure that kit supplies are fully replenished, clean, and not expired.
--------------------------------	---

Inspect First Aid Kit Mounting Bracket	Ensure that mounting bracket is secure and operates correctly.
--	--

Emergency Exits

Inspect All Emergency Exits	Test all emergency exits for proper operation, including warning buzzer.
-----------------------------	--

Warning Devices & Signs

Test Stop Arms & Crossing Arms	
--------------------------------	--

Windows

Inspect All Mirrors	Clean, adjust mirrors.
---------------------	------------------------

Inspect All Windows	Clean windshield, door glass, driver's window, rear vision windows, rear door windows.
---------------------	--

Brakes

Inspect Air Brakes Air Lines & Fittings	Inspect for leaks or physical damage.
---	---------------------------------------

Drain Air Brakes Air Tanks	Drain daily in cold weather; weekly in warm weather.
----------------------------	--

Inspect Air Brakes Brake Chambers	See Air Brakes Chapter for inspection criteria.
-----------------------------------	---

Inspect Air Brakes Brake Shoes	Wear depends upon application environment. See Meritor Cam Brakes Appendix in Air Brakes Chapter of Service Manual for guidelines.
--------------------------------	--

Cooling System

Inspect Coolant Level	Adjust to proper level with premixed coolant of same type as installed. Never mix coolants of different colors, types, or brands. See engine Operator's Manual for details. See decal on vehicle showing original equipment.
-----------------------	--

Inspect Entire Cooling System	Visually inspect for any signs of leakage.
-------------------------------	--

Electrical

Inspect All Lights	Check all running, stop, marker, hazard, and warning lights for proper operation.
--------------------	---

Engine

Inspect Oil Level	See engine operators manual for oil specifications.
-------------------	---

Fuel System

Inspect Fuel Cap	
------------------	--

Inspect Water Separator Petcock Drain	Check for water contamination.
---------------------------------------	--------------------------------

Intake System

Inspect Intake Tract Duct & Elbow	Visually inspect for proper fit and sealing, cuts, abrasions, signs of dirt contamination.
-----------------------------------	--

Inspect Intake Tract Restriction Indicator	Replace primary filter element when gauge on Filter Minder goes into the red area, regardless of time or mileage. If filter has secondary or safety filter, replace at minimum every 2nd primary filter replacement.
--	--

Steering

Inspect Power Steering Fluid Level	Replenish to full mark. Dexron III or approved equal.
------------------------------------	---

Tires & Wheels

Inspect All Tires & Wheels	Check air pressure. Visually inspect tires, tread wear, lug nuts, including spare.
----------------------------	--

Transmission

Inspect Transmission Fluid Level	Check production order for proper type of fluid to be added.
----------------------------------	--

**Every Week****Seats**

Inspect & Tighten Passenger Seats Cushion
Screws

Inspect for loose cushions clips.

Inspect Passenger Seats Seat Belts

Lubricate buckles, clean webbing as required. Replace any
damaged webbing straps.

Inspect Passenger Seats Upholstery

Inspect for cuts, tears, wear and soiled areas.

Brakes

Inspect Hydraulic Brakes Pads

Replace if worn to within 1/8" lining remaining.

Every 60,000 Miles**Fuel System**

Replace Fuel Filter

Every Month or 3000 Miles

Doors

Clean & Lubricate All Doors Rubber Seals	Lubricate with Silicon Spray or protectant.
Adjust Outward Opening Door Control Rod	
Adjust Outward Opening Door Control Rod Bracket	Adjust for full and secure closure without binding.
Adjust & Lubricate Outward Opening Door Linkage	Adjust linkage for firm closure, and to ensure rear panel closes first.
Lubricate Outward Opening Door Pivots	Lubricate pivot pins with LPS #1.
Adjust Outward Opening Door Roller Bracket	Adjust for full and secure closure without binding.
Lubricate Wheelchair Lift Lube Points	See model-specific literature provided with lift.

Emergency Exits

Lubricate All Emergency Exits Hinges	LPS #1
Lubricate Rear Emergency Door Hold-Open	Apply ASTM D4950 GC-LB Grade 2
Lubricate Roof Hatch Seal and Latch	Use silicone lubricant to prevent sticking of rubber seal. Spray silicone lubricant into latch mechanism.

Floor

Inspect Floor Drains	Check drain hole in each body section under window for debris or obstruction.
----------------------	---

Seats

Lubricate Driver's Seat	Lubricate per manufacturers recommendation.
Inspect & Tighten Passenger Seats Mountings	Use standard torque for bolt size, thread type and grade.

Warning Devices & Signs

Lubricate Stop Arm, Electric 4-Point Pivot	Lubricate four hinge pivot points with Try-Flow lubricant
Inspect & Tighten Stop Arm, Electric Fasteners	Check interior and exterior fasteners for loosening.



Windows

Lubricate Passenger Windows Latches & Slides	Use silicone lubricant.
--	-------------------------

Brakes

Inspect Hydraulic Brakes Fluid	DOT-3 brake fluid.
Adjust Hydraulic Brakes Park Brake Lever	Adjust engagement pressure at the foot pedal to achieve 130-150 lbs. on the fourth "click" on the parking brake lever detent.
Inspect Hydraulic Brakes Interlock Fluid	DOT-5 brake fluid.

Doors

Lubricate All Doors Vandal Locks	Apply spray lubricant into key locks. Use LPS #1 for sliding bolt locks.
----------------------------------	--

Electrical

Inspect Battery Electrolyte Level	Replenish with distilled water.
-----------------------------------	---------------------------------

Every Month or 5000 Miles

Warning Devices & Signs

Inspect Stop Arm, Air Pressure	Adjust for full deployment and retraction.
--------------------------------	--

Every Month or 12,000 Miles

Axle & Suspension, Rear

Inspect Rear Axle Lubricant Level	If low, refill to bottom of filler opening. Use same lubricant type as already installed.
-----------------------------------	---

Every 3 Months

Exterior Structure

Wash Body	Wash the vehicle in lukewarm or cold water. Do not use hot water or wash in the direct sunlight. Only cleaners with an HMIS rating of 1,0,0,0 or less should be used to clean the buses. See Exterior Cleaning section of Driver's Handbook for further information.
-----------	--

Every 3 Months or 3000 Miles

Emergency Exits

Lubricate Rear Emergency Door Hinges	LPS #1
--------------------------------------	--------

Cooling System

Inspect Radiator Fins	Clean debris from fins.
Inspect Water Pump Belt	Inspect condition and tension of belt.

Every 3 Months or 5000 Miles

Brakes

Lubricate Air Brakes S-Cam	See Meritor Cam Brakes Appendix in Air Brakes Chapter of Service Manual for guidelines.
----------------------------	---

Lubricate Hydraulic Brakes Calipers	Lube per Meritor specs.
-------------------------------------	-------------------------

Cooling System

Inspect Intake Tract Charged Air Tubing	Inspect for signs of contaminate infiltration, loose clamps, wear spots, holes in piping.
---	---

Inspect & Tighten Intake Tract Hose Clamps	Tighten to 5 ft lb.
--	---------------------

Electrical

Inspect Alternator Connections	Inspect for loose wires, damaged terminals, damaged insulators.
--------------------------------	---

Inspect Battery Connections	Check for solid connection, tight fasteners and absence of corrosion.
-----------------------------	---

Fuel System

Inspect Fuel Lines	Inspect for leaks or signs of abrasion.
--------------------	---

Inspect Fuel Tank Vent	Inspect for obstruction.
------------------------	--------------------------

Intake System

Inspect Air Cleaner Filter Element	Inspect for proper seating, secure lid. Replace if soiled, wet, or damaged.
------------------------------------	---

Inspect Intake Duct and All Fasteners	Inspect for signs of contaminate infiltration, loose clamps, wear spots, holes in piping
---------------------------------------	--

Inspect Intake Tract Support Bracket	Visual inspection. Repair damaged parts immediately.
--------------------------------------	--

Inspect & Tighten Intake Tract T-Bolt Clamps	Tighten to 7 ft lb.
--	---------------------

Inspect & Tighten Intake Tract Worm Gear Clamps	Tighten to 38-42 in lb.
---	-------------------------



Steering

Lubricate Axle Steering Linkage Drag Link	NLGI #2 EP multipurpose grease rated GC-LB or equivalent.
Lubricate Axle Steering Linkage King Pins	NLGI #2 EP multipurpose grease rated GC-LB or equivalent.
Lubricate Axle Steering Linkage Tie Rod Ends	NLGI #2 EP multipurpose grease rated GC-LB or equivalent.
Lubricate Intermediate Steering Shaft Slip Joint	NLGI #2 EP multipurpose grease rated GC-LB or equivalent

Every 3 Months or 24,000 Miles

Brakes

Inspect Air Brakes Air Dryer	See Bendix appendix for specific model in Air Brakes Chapter of Service Manual.
Inspect Hydraulic Brakes Booster & Master Cylinder	Inspect for signs of leakage or physical damage.

Every 6 Months or 5000 Miles

Warning Devices & Signs

Lubricate Destination Sign Hinges	
Lubricate Destination Sign Roller Gears	Lightweight grease such as White Lube.

Every 6 Months or 6000 Miles

Brakes

Clean Air Brakes Check Valves

Clean & Lubricate Air Brakes Treadle Valve

See Bendix Treadle Valve Appendix in Air Brakes Chapter of Service Manual.

Clean Air Compressor Governor

Inspect Hydraulic Brakes Calipers

Inspect for signs of leakage or physical damage.

Cooling System

Replace Coolant Filter

Lubricate Shutters Pivots

Use Never Seize spray lubricant.

Electrical

Inspect Battery Posts

Clean and apply anti corrosion agent.

Exhaust System

Inspect Exhaust Pipe Joints

Inspect for loose clamps, leaks, damage.

Fuel System

Replace Fuel Filter Filter Element

Clean Fuel Filter Inlet Screen

Clean. Replace if damaged.

Steering

Lubricate Steering Gear Pitman Arm Pivot

NLGI #2 EP multipurpose grease rated GC-LB or equivalent. Use hand-operated grease gun.

Every 6 Months or 12,000 Miles

Brakes

Lubricate Air Brakes Cam Shaft Housing

NLGI #2 EP multipurpose grease rated GC-LB or equivalent. Use hand-operated grease gun.

Lubricate Air Brakes Haldex Slack Adjusters

See Haldex lubricant specs in Air Brakes chapter of Service Manual.

Lubricate Air Brakes Meritor Slack Adjusters

See Meritor lubricant specs in Air Brakes chapter of Service Manual.

Every 6 Months or 25,000 Miles
Axle & Suspension, Front

Inspect & Torque AirTek Suspension Air Spring to Air Spring Bracket	Torque to 20-30 ft lb.
Inspect & Torque AirTek Suspension Air Spring to Top Pad	Torque to 20-30 ft lb.
Inspect & Torque AirTek Suspension Clamp Group Hardware	Torque to 285-305 ft lb.
Inspect & Torque AirTek Suspension Front Frame Hanger to Front Leaf Spring Eye	Torque to 290-310 ft lb.
Inspect & Torque AirTek Suspension HVC Linkage to HVC Arm	Torque to 10-12 ft lb.
Inspect & Torque AirTek Suspension Rear Shackle Bracket to Shackle Plate	Torque to 290-310 ft lb.
Inspect & Torque AirTek Suspension Rear Shackle Bracket to Spring Eye	Torque to 290-310 ft lb.
Inspect & Torque AirTek Suspension Shackle Bracket Lock Nuts	Torque to 114-126 ft lb.
Inspect & Torque AirTek Suspension Shocks Eye Bolts	Torque to 125-135 ft lb.
Inspect & Torque SofTek Spring Suspension Axle Clamp Group Nuts	Torque to 285-305 ft lb.
Inspect & Torque SofTek Spring Suspension Front Frame Hanger to Front Leaf Spring Eye	Torque to 290-310 ft lb.
Inspect & Torque SofTek Spring Suspension Rear Shackle Bracket to Shackle Plate	Torque to 290-310 ft lb.
Inspect & Torque SofTek Spring Suspension Rear Shackle Bracket to Spring Eye	Torque to 290-310 ft lb.
Inspect & Torque SofTek Spring Suspension Shackle Bracket Lock Nuts	Torque to 114-126 ft lb.

Inspect & Torque SofTek Spring
Suspension Shocks Eye Bolts

Torque to 125-135 ft lb.

Axle & Suspension, Rear

Inspect & Torque Comfort Air Suspension
Air Spring to Cross Channel

Torque to 20–30 ft lb.

Inspect & Torque Comfort Air Suspension
Cross Channel to Main Support Member

Torque to 260-320 ft lb.

Inspect & Torque Comfort Air Suspension
HCV Linkage to Height Control Valve Arm

Torque to 80–90 in lb.

Inspect & Torque Comfort Air Suspension
Height Control Valve to Frame Bracket

Torque to 40–50in lb.

Inspect & Torque Comfort Air Suspension
Linkage Rod Assembly Locknut

Torque to 80-90 in lb.

Inspect & Torque Comfort Air Suspension
Quick Align Bolts

Torque to 525–575 ft lb.

Inspect & Torque Comfort Air Suspension
Shock Absorbers

Inspect for leakage or damage. Torque mount bolts to 160–180 ft lb.

Inspect & Torque Comfort Air Suspension
Suspension Hanger

Torque to 175 ft lb.

Inspect & Torque Comfort Air Suspension
Transverse Torsion Rod to Axle Bracket

Torque to 90-122 ft lb.

Inspect & Torque Comfort Air Suspension
Transverse Torsion Rod to Frame

Torque to 90-122 ft lb.

Inspect & Torque Comfort Air Suspension
U-Bolts

Torque 7/8" U-Bolts to 400–450 ft lb. Torque 3/4" U-Bolts to 285–305 ft lb.

Inspect Comfort Air Suspension Whole
Assmebly

Visually inspect for damage.



Driveline

Inspect & Torque SPL 100 & 70
Driveshafts U-Joint Bolts

Inspect for wear and damage every time vehicle is serviced. Torque to 45–50 ft lb.

Lubricate SPL 140 Driveshafts U-Joint
Bolts

Grease meeting NLGI Grade #2 grease specifications.

Inspect & Torque SPL140 & 170
Driveshafts U-Joint Bolts

Inspect for wear and damage every time vehicle is serviced. Torque to 115-135 ft lb.

Every 12 Months

Exterior Structure

Wax Body

Use of a nonabrasive wax is recommended to remove accumulated residue and eliminate any "weathered appearance". It is essential that units are not waxed in direct sunlight. See Exterior Cleaning section of Driver's Handbook for further information and approved waxes.

Intake System

Test Intake Tract Restriction Indicator

Test indicator with vacuum gauge and pump.

Every 12 Months or 12,000 Miles

Heaters & Defrosters

Tighten Front Heater Fasteners	All fasteners holding such heaters in place in unit. For details on fasteners check installation prints.
Inspect, clean and replace Front Heater Filter & Screen	Wash filter and screen. If filter cannot be washed or is damaged, the filter MUST be replaced immediately. If a screen cannot be cleaned, a new screen must be installed immediately.
Inspect and clean Front Heater Heater Cores	Clean carefully with compressed dry air or vacuum and a soft bristle brush. Damaged fins should be straightened with a fin comb.
Inspect and clean Heater Cores	The core should be cleaned carefully with compressed dry air or vacuum and a soft bristle brush. Damaged fins should be straightened with a fin comb to prevent airflow restrictions.
Bleed Heater System	Bleed air from heater circulation system. This procedure is done to keep system operating correctly.
Inspect, clean or replace Heater System Filter	The filter and screen are washable. If a filter cannot be washed or is damaged, the filter MUST be replaced immediately. If the screen cannot be cleaned, a new screen must be installed immediately. Filter may need to be cleaned or replaced more frequently in extreme dusty and dirty environments.
Clean Underseat Heaters Filter Elements	Clean dust from cores.
Axle & Suspension, Front	
Inspect & Adjust AirTek Suspension Ride Height	Shock Length, eye-to-eye: 17.25" +/- 0.25"
Axle & Suspension, Rear	
Inspect & Torque Spring Suspension Shock Absorbers	Inspect for signs of leakage, wear, or damage. Torque locknuts to 75-100 ft lb.
Inspect & Torque Spring Suspension U-Bolts	Torque u-bolt nuts to 280-310 ft lb.



Cooling System

Test Entire Cooling System	Pressure Test Cooling system.
----------------------------	-------------------------------

Clean Radiator Fins	Clean as required.
---------------------	--------------------

Engine

Test Engine Starting Aid Block Heater	
---------------------------------------	--

Steering

Inspect Hydraulic Pump Body & Seals	Inspect for leaks.
-------------------------------------	--------------------

Inspect Steering Gear Body & Seals	Inspect for leaks.
------------------------------------	--------------------

Every 12 Months or 24,000 Miles

Brakes

Clean Air Brakes Pop Off Valves	
---------------------------------	--

Steering

Replace Hydraulic Reservoir Filter Element	Replace element and fluid. Replace more frequently in severe operating conditions. Dexron III or approved equal.
--	--

Transmission

Replace Transmission Fluid	Use TransSynd fluid.
----------------------------	----------------------

Inspect Transmission Shift Cable	
----------------------------------	--

Inspect Transmission Vent	Clear vent of debris or obstruction.
---------------------------	--------------------------------------

Every 12 Months or 50,000 Miles

Axle & Suspension, Rear

Replace Rear Axle Petroleum Based Lubricant	Hypoid Gear Oil. Viscosity depends upon operating climate. See Viscosity/Temperature chart.
---	---

Every 12 Months or 90,000 Miles

Axle & Suspension, Rear

Replace Rear Axle Synthetic Lubricant	Viscosity depends upon operating climate. See Viscosity/Temperature chart.
---------------------------------------	--

Every 24 Months or 24,000 Miles

Brakes

Clean Air Brakes Parking Brake Valve	See Bendix Appendixes in Air Brakes Chapter.
Clean Air Brakes Quick Release Valves	See Bendix Appendixes in Air Brakes Chapter.
Clean Air Brakes Relay Valves	See Bendix Appendixes in Air Brakes Chapter.
Clean Air Brakes Spring Brake Valve	See Bendix Appendixes in Air Brakes Chapter.

Intake System

Replace Air Cleaner Filter Element

Every 24 Months or 225,000 Miles

Exhaust System

Replace DEF Supply Module Filter

Replace DEF Tank Head Unit Filter

Maintenance Locations

- | | |
|-------------------------------------|----------------------------|
| 1. Intake Air Restriction Indicator | 8. Not Applicable |
| 2. Rear Axle Lubricant | 9. Brake Camshaft |
| 3. Axle Vent | 10. Brake Slack Adjusters |
| 4. King Pin | 11. Automatic Transmission |
| 5. Tie Rod | 12. Universal Joints |
| 6. Drag Rod | 13. Driveline |
| 7. Steering Gear | |

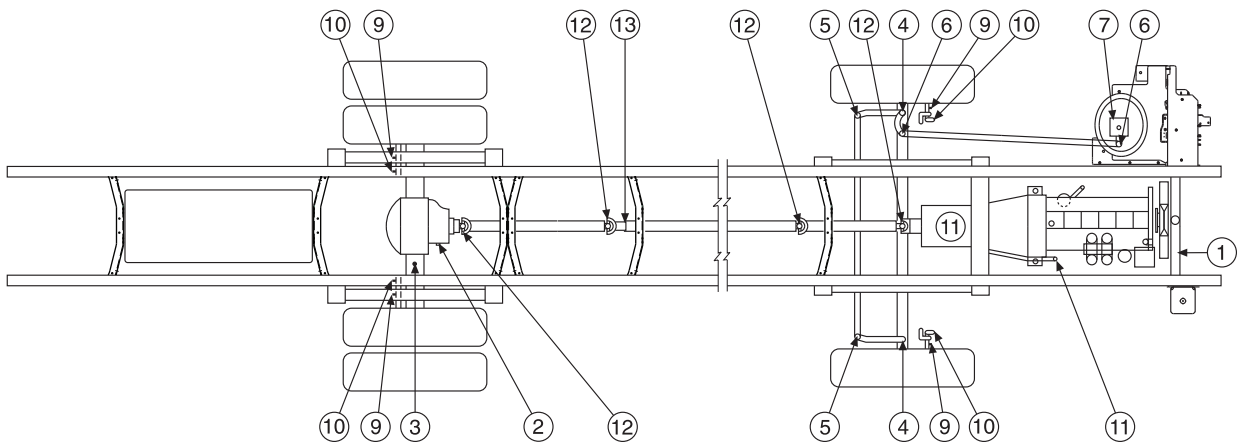

All American Front Engine



General Data

Dimensions

HEADROOM: 78 INCHES

EXTERIOR HEIGHT: APPROXIMATELY 122 INCHES

EXTERIOR HEIGHT W/AC: ADD 16 INCHES

EXTERIOR WIDTH: 96 INCHES

INTERIOR WIDTH: 90.75 INCHES

Fluid Capacities (In Quarts)

	Crankcase Oil	**Engine Coolant	Auto Trans. Fluid	Power Steering Fluid
Cummins ISB	19.5 w/Filter	41.0 Fixed Radiator 41.5 Swing Radiator	16.75 (2500 Transmission) 31.0 (3000 & B300 Trans.)	4.36 Hydraulic Brakes 2.70 Air Brakes

****NOTE:** Engine coolant capacities are not inclusive of additional passenger compartment heater options.

Engine Oil Pressure

CUMMINS ISB: 40–50 PSI @ 2,500 RPM, WARM

PUBLICATION
NUMBER
10026198

COUNT ON BLUE BIRD



BLUE BIRD

TECHNICAL PUBLICATIONS

Post Office Box 937 • Fort Valley, Georgia 31030, USA • www.blue-bird.com