

Comfort Aire

AIR CONDITIONING SYSTEMS



BLUE BIRD

TechPlus

S E R V I C E S U P P L E M E N T





Technical Communications

TechPlus Supplement

for

Comfort Aire

School Bus Air Conditioning Systems

on

Blue Bird All American Forward Engine

Blue Bird All American Rear Engine

Blue Bird Vision

Blue Bird MicroBird

© 2006, 2007 Blue Bird Corporation. All rights reserved.

In the event of any conflict between the requirements of this publication and any applicable legal requirement, the legal requirement prevails. Technical requirements that exceed the legal requirements are not considered to conflict.

The material presented in this manual is accurate at the time of publication. Blue Bird Corporation continually endeavors to improve its product and reserves the right to change without notice.

About Blue Bird TechPlus Supplements

School buses are built with a wide array of equipment features which vary not only according to manufacturer's models, but also according to state governmental regulations and customer-specifications. Such features often apply to a relative few buses sold within a particular model category; and some features involve complex systems or components which require appropriately detailed service information.

For these reasons, including full documentation of every available feature in the printed version of the primary Service Manual for a particular bus model is not always practical. Blue Bird's Technical Communications group prepares and publishes TechPlus Supplements for such situations.

Intended Readership

This TechPlus Supplement is written for fully qualified professional Service Technicians in specific areas performing maintenance and repair of Blue Bird buses. It is assumed that the user of this publication is properly equipped and abides by all appropriate safety precautions and procedures.

Content Sources

Blue Bird's Technical Communications group is a full-time staff within the Customer Services division at the home plant in Fort Valley, Georgia, where its Tech Publishers have full access to Blue Bird's assembly lines and Engineering department.

Blue Bird incorporates into its buses top quality components from leading manufacturers in the heavy automotive industry. The Engineering staffs of these component vendors are the real experts on their specific components. These manufacturing partners often provide their own publications to Blue Bird Technical Communications for republishing as appendixes within Blue Bird's Service Manuals for direct-from-the-source, component-specific information.

Therefore, content in TechPlus publications may be written by Blue Bird's own Technical Publishers; or may be provided by Blue Bird's manufacturing partners; or may be comprised of both Blue-Bird authored and vendor-authored material.

The bulk of this TechPlus Supplement is prepared by Blue Bird's vendor, Mobile Climate Controls, which builds the Comfort Aire air conditioner units to Blue Bird specifications.

Subject of This Supplement

This Service Supplement is prepared to provide additional information to qualified school bus Service Technicians regarding the Comfort Aire air conditioning systems installed as an option on some Blue Bird school buses.

Applicable Bus Models

Comfort Aire air conditioning systems are installed on these Blue Bird models:

Blue Bird All American Forward Engine

Blue Bird All American Rear Engine

Blue Bird Vision

Blue Bird MicroBird



Blue Bird Comfort Aire

Maintenance Manual

For

All American (A3FE/RE),
Conventional Vision (BBCV) & Micro
Bird Body Types
(REVISION.003)

Important Information about Using This Manual

Please note that this manual is included with all Blue Bird buses equipped with the Blue Bird factory installed and supported Comfort Aire, air conditioning system.

Therefore the user will find the manual body to provide excellent safety practices, driver instructions and simple trouble shooting, technician instructions and detailed trouble shooting/replacement procedures. As well as recommended regular maintenance checks for both the driver and technician.

The manual body shows detailed three dimensional models of only the large 55,000 BTU/hr evaporators and the dual core large bus condenser. All other evaporator and condenser configurations share the same basic components.

The appendix pages at the end will contain an assembled view drawing with basic data, exploded view drawings and part number lists for each evaporator and condenser configuration offered.

Please refer to the MCC part number on the label attached to the outside surface of each component's metal casing to determine which unit you are working with.

The appendix also contains large wiring schematics for each bus configuration.



Safety Precautions / 10

General Practices / 10

Refrigerant / 11

First Aid / 11

Refrigeration Oil / 11

First Aid / 11

Electrical Hazards / 12

High Voltage / 12

Precautions / 12

First Aid / 12

Low Voltage / 13

Comfort Aire Specifications / 14

General / 14

R-134a Refrigeration System Charges and Set-points / 14

A3RE/FE & BBCV with TM-21's Electrical System / 15

Micro Bird Electrical System / 15

Maintenance Inspection Schedule / 16

General Unit Description / 17

General Unit Operation / 18

Cooling / 18

Evaporator Coil Defrost / 18

Unit Features / 18

Protection Features / 18

General System Component Details / 19

Stacked Skirt Mounted Condenser Configuration / 19

Stacked Skirt Mounted Condenser Exploded View / 20

55,000 Bth/hr Free Blow Evaporator Configuration / 21

55,000 Btu/hr Free Blow Evaporator Exploded View / 22

Typical TM-21 Compressor / 23

Manual Control Panel / 23

High Pressure Binary Switch / 24

Electronic Thermostat / 24

Driver Instructions and Information / 25

Starting the Unit / 25

Bi Monthly Post Trip Checks / 26

Regular Maintenance by Driver / 26

Basic Trouble Shooting for Driver / 26

Technician Instructions and Information / 28

- Charging the Air Conditioning System / 28
- Checking the Refrigerant Charge / 29
- Checking the Compressor Oil Charge / 29
- High Pressure Binary Switch / 29

Clean Up Procedures / 31**Part Replacement Procedures / 33**

- Compressor / 33
- Condenser Coil / 34
- Receiver Drier / 34
- High Pressure Binary Switch / 35
- Evaporator Coil / 35
- Expansion Valve Assembly / 36

Structural Maintenance / 38

- Unit Inspection / 38
 - Evaporator Coil / 38
 - Condenser Coil / 38
 - Mounting Bolts / 38

TM-21 & TM-16 Compressor and Clutch Maintenance / 39

- Operation / 39
- Inspection / 39
- Clutch Removal / 40
- Clutch Installation / 42
- Electrical Connection / 45
- Compressor Front seal Removal and Installation / 45

System Compressor and Oil Handling / 50

- Installation of the Compressor / 50
- Major Loss or Refrigerant / 50
- Checking the Oil Level / 50
- Oil Contamination / 51
- When a system becomes contaminated / 51
- Electrical Connection / 51
- Clutch Test / 51

Belt Tensions / 52

- Engine Compressor Belts and Pulleys / 52
- Single V-Belt – Cat C7 A3RE/FE / 52
- Poly V-Bel - Some A3RE/FE, All BBCV and All MicroBird / 52



General Trouble Shooting By Technician / 53

- Blower Motor Does Not Operate / 53
- Blower Motor Operates Normally, But Air Flow is Insufficient / 53
- Insufficient cooling, does not operate at all, or operates improperly / 53
- The compressor does not operate at all, or operates improperly / 53
 - Gauge Pressure Related Troubleshooting / 54
 - Operation to Return Oil to the Compressor / 54

Electrical System Trouble Shooting / 56

- Compressor Trouble Shooting / 57
- Refrigeration Diagnosis Chart / 58
- System Service and Maintenance Notes / 59
 - Service Guidelines / 59
 - Compressor Oil Charge / 59

Refrigeration Chart / 61

Wiring Schematics / 62

- Micro Bird Manual / 62
- Micro Bird ECC / 63
- BBCV, A3RE, A3FE Manual / 64
- BBCV, A3RE, A3FE ECC / 65
- Slimline System Manual / 66
- Slimline System ECC / 67

Electronic Control User Guide / 68

- Electronic Climate Control (ECC) / 69
 - ECC Control / 70
 - ECC User Display / 71
- Basic Operation / 72
- System Diagnosis / 73

System Schematics / 75

- A3RE ECC Roof Top Condenser / 76
- Engine Kit Compressor / 77

Safety Precautions

General Practices

1. **ALWAYS WEAR GOGGLES OR SAFETY GLASSES**, refrigerant liquid, refrigeration oil, and battery acids can permanently damage the eyes.
2. Never operate the system with the compressor discharge valve closed
3. Keep your hands, clothing and tools clear of the fans and belts when the system is running. This should also be considered when opening and closing compressor valves.
4. Make sure gauge manifold hoses are in good condition. Never let them come in contact with a belt, fan pulley, or any hot surface.
5. Never apply heat to sealed air conditioning system components or container.
6. Fluorocarbon refrigerants, in the presence of an open flame or electrical short, produce toxic gases that are severe respiratory irritants capable of causing death.
7. Make sure that all mounting bolts are tight and the correct length for their particular application.
8. Use extreme caution when drilling in the units. The holes may weaken structural components, and holes drilled into electrical wiring can cause fire or explosion. Drilled holes may also puncture pressurized system components causing leaks, exercise caution when drilling close to coil, tubing, hoses and other system components.
9. Use caution when working around exposed coil fins. The fins can cause painful lacerations.
10. Use caution when working on a refrigerant or air conditioning system in any enclosed or confined area with a limited air supply, Refrigerant gas will displace air causing oxygen depletion resulting in suffocation and possible death.
11. EPA Section 608 is required to work on Air Conditioning Systems.



Refrigerant

Although fluorocarbon refrigerants are classified as safe refrigerants, certain precautions must be observed when handling them or servicing a unit in which they are used. When exposed to the atmosphere from the liquid state, fluorocarbon refrigerants evaporate quickly freezing anything in the near vicinity. Including causing frost bite if spilled on skin.

First Aid

In the event of frost bite, the objectives of first aid are to protect the frozen area from further injury, to warm the affected area rapidly and to maintain respiration.

- **EYES:** For contact with liquid, immediately flush eyes with large amount of water and seek prompt medical attention.
- **SKIN:** Flush area with a large amount of lukewarm water. Do not apply heat. Remove contaminated clothing and shoes. Wrap burns with dry, sterile, bulky dressing to protect from infection/injury. Seek medical attention. Wash contaminated clothing before reuse.
- **INHALATION:** Move victim to fresh air and use CPR if necessary. Stay with victim until arrival of emergency medical personnel.

Refrigeration Oil

Avoid refrigeration oil contact with the eyes. Avoid prolonged or repeated contact of refrigeration oil with skin or clothing. Wash thoroughly after handling refrigeration oil to prevent irritation.

First Aid

- **EYES:** For contact with oil, immediately flush with plenty of water for at least 15 minutes. Call Physician if irritation persists.
- **SKIN:** Wash skin with soap and water. Call Physician if irritation persists.

Electrical Hazards

High Voltage

When servicing or repairing an air conditioning unit, the possibility of serious or even fatal injury from electrical shocks exists. Extreme care must be used when working with an operating air conditioning system. Lethal voltage can exist on connections on the high voltage side of the system.

Precautions

1. When working on high voltage circuits on the air conditioning units, do not make any rapid moves. If a tool drops, do not grab for it. People do not contact high voltage wires on purpose. It occurs from an unplanned movement.
2. Use tools with insulated handles that are in good condition. Never hold metal tools in your hand if exposed, energized conductors are in reach.
3. Treat all wires and connections as high voltage until a meter or wiring diagram show different.
4. Never work alone on high voltage circuits on an air conditioning unit, another person should always be standing by in the event of an accident to shut off the air conditioning unit and to aid a victim.
5. Have electrically insulated gloves, cable cutters, and safety glasses available in the immediate vicinity in the event of an accident.

First Aid

IMMEDIATE First Aid must be initiated after a person has received an electrical shock. Check for pulse and breathing; perform CPR (Cardio Pulmonary Resuscitation) if either is absent. Obtain immediate medical assistance.

The source of shock must be immediately removed by either shutting down the power or removing the victim from the source. If it is not possible to shut off the power, the wire should be cut with either an insulated instrument (e.g. a wooden handle axe or cable cutters with heavily insulated handles) or by a rescuer wearing electrically insulated gloves and safety glasses. Whichever method is used do not look at the wire while it is being cut. The ensuing flash could cause burns and blindness.

If the victim has to be removed from the live circuit, pull the victim off with a non conductive material. Use the victim's coat, or rope, wood or loop your belt around the victim's leg or arm and pull the victim off. **DO NOT TOUCH** the victim. You can receive a shock from current flowing through the victim's body. After



separating the victim from the power source, check immediately for presence of pulse and respiration. If pulse is not present, START CPR and call for emergency medical assistance. If a pulse is present, Respiration may be restored by using mouth to mouth resuscitation, but call for emergency medical assistance.

Low Voltage

Control circuits used in air conditioning systems are low 12/24 volts dc. This voltage potential is not considered dangerous, but the large amount of current available (over 30 Amperes) can cause severe burns if shorted to ground.

Do not wear jewelry, watch or rings. These items can short out electrical circuits and cause severe burns to wearer.

Comfort Aire Specifications

General

Compressor	ICE TM-21 for A3 and BBCV ICE TM-16 for Micro Bird Both belt driven by the engine
Compressor Oil Charge	5 oz. per compressor
Compressor oil Type	PAG (Poly Alkylene Glycol)
Defrost Method	Electronic Thermostat Opens at 30-32 °F coil temp Closes at 35-37 °F coil temp
Belt Tension	120 lbs for non-auto tensioned arrangements

R-134a Refrigeration System Charges and Set-points

A3FE

Blue System (Curb Side)	4.75 lbs.
Black System (Road Side)	4.3 lbs,

A3RE with TM-21's

Blue System (Curb Side)	5.75 lbs.
Black System (Road Side)	5.0 lbs

BBCV

Blue System (Curb Side)	4.75 lbs.
Black System (Road Side)	4.0 lbs.

Roof Mount Condenser Buses with TM-21's

Blue System (Curb Side)	6.2 lbs.
Black System (Road Side)	4.3 lbs.

Micro Bird

Rear System	4.25 lbs.
-------------	-----------

High Pressure Binary Cut Out Switch	High Side Opens at 384 P.S.I. Low Side Opens at 28 P.S.I.
-------------------------------------	--



A3RE/FE & BBCV with TM-21's Electrical System With Stacked Skirt Mounted Condenser

Evaporator # 1 Circuit Breaker	50 amps
Evaporator # 2 Circuit Breaker	50 amps
Stacked Condenser Circuit Breaker	35 amps
Control System # 1 Circuit Breaker	7 amps
Control System # 2 Circuit Breaker	7 amps

A3RE/FE & BBCV with TM-21's Electrical System With Roof Top Condenser Pair

Evaporator # 1 Circuit Breaker	50 amps
Evaporator # 2 Circuit Breaker	50 amps
Roof Top Condenser # 1 Circuit Breaker	25 amps
Roof Top Condenser # 2 Circuit Breaker	25 amps
Control System # 1 Circuit Breaker	7 amps
Control System # 2 Circuit Breaker	7 amps

Micro Bird Electrical System

Evaporator Circuit Breaker	50 amps
Condenser Circuit Breaker	25 amps
Control System Circuit Breaker	7 amps

Maintenance Inspection Schedule

Weekly	Monthly	Semi Annual	Annual	Inspect/Service These Items
				Electrical
		•	•	Check Compressor clutch operation
		•	•	Inspect D.C. fan motors
		•	•	Inspect wiring harness for damaged wires or connectors
			•	Clean and re lubricate power studs at condenser
				Refrigeration
	•	•	•	Check refrigerant level
		•	•	Replace receiver drier
			•	Check refrigeration lines for signs of rubbing, damage, and oil leaks
			•	Perform acid test on compressor oil
				Structural
•	•	•	•	Visually inspect unit for loose or broken parts
•	•	•	•	Clean defrost drains
•	•	•	•	Inspect belts for proper tension
	•	•	•	Clean entire condenser and evaporator coils
	•	•	•	Check all mounting bolts

Note: Use only PAG (Poly Alkylene Glycol) compressor oil in R-134a systems
 Do not mix PAG compressor oil with other synthetic oils
 Keep PAG oil in tightly sealed containers. If oil becomes contaminated with moisture (colour will change to milky) or standard oils, dispose of properly – Do Not Use

Note: When servicing a R-134a system, use only those service tools certified for and dedicated to R-134a refrigerant and PAG compressor oils
 Residual or non HFC refrigerants or oils will contaminate the R-134a System

Note: Recover all refrigerant and re cycle or dispose of properly



General Unit Description

The Blue Bird air conditioning unit is designed to provide comfort, at temperatures between 70 - 80 °F.

The typical A3RE/FE and BBCV system consists of three separate assemblies; the condenser, evaporator and compressor. The Micro Bird has two completely separate condenser, evaporator and compressor sets; the rear Comfort Aire and chassis OEM system.

Comfort Aire offers condensers uniquely designed pair to mount on the roof, or inside the skirt of the bus on the driver's side. The large bus skirt side condenser comes equipped with two separate condenser coils and three fans. Each of the two roof top condenser units have a single coil and two fans.

The Evaporators are mounted inside of the bus, in this instance there are two evaporators, one mounted on the curbside of the bus (Rear 1 Evaporator), the other mounted on the road side of the bus (Rear 2 Evaporator). There is a third non MCCII evaporator, incorporated into the front heater/defroster. This evaporator is connected to the blue system hoses via a set of T-connections.

The compressors are mounted on top of the engine for the BBCV and underneath of the CAT engines and on top of Cummins engines for the A3RE/FE. The compressors are driven by the bus engine. Refrigeration lines are used to connect the condenser, evaporator and compressor.

The two systems work separately.

Compressor operation is controlled by the drivers control switches and thermostat, which energize the compressor clutch during engine operation. The refrigeration system is protected by H. P. Binary Switch

Below is a typical arrangement for a BBCV or A3FE with roof top condensers.

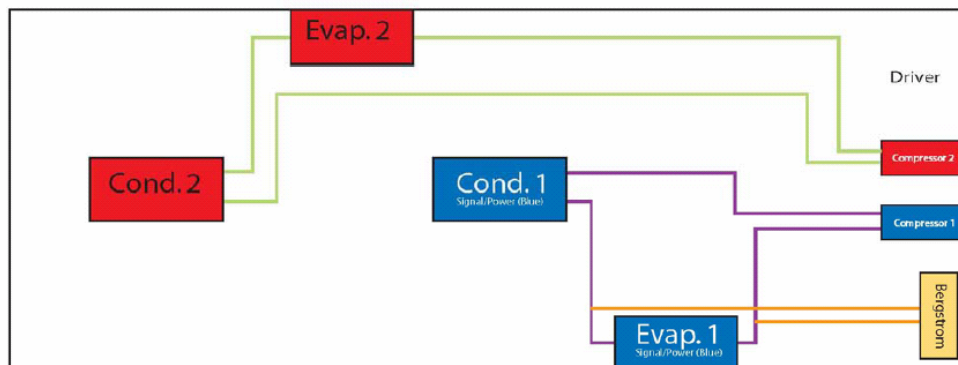

General Unit Operation

The unit will start operating as the driver turns on the blower switch for each side of the bus; this sends electrical power to the compressor clutch. The compressor clutch will engage as it is turned by the bus engine, through a compressor drive belt.

Cooling

With the blower switch turned on and the temperature selector turned (counterclockwise) towards the (C), electrical power is sent to the electronic thermostat and through the H.P. Binary Switch, and the compressor clutch. The compressor clutch will engage, through a drive belt connected to the engine. The engine will then turn the compressor.

During engine operation, the engine compressor, evaporator fans and condenser fans operate while the unit is in cool.

Evaporator Coil Defrost

The defrost cycle can initiate at any time the evaporator coil reaches a temperature of 30-32 °F. This is controlled by the electronic thermostat and will de-energize power to the compressor clutch. When the evaporator reaches 35-37 °F the thermostat will kick in and energize the compressor clutch.

Unit Features

- Dash mounted driver control
- Electronic Thermostat
- Compressor
- R-134a

Protection Features

- Control circuit breakers
- High Pressure – Low Pressure Binary Switch



General System Component Details

Stacked Skirt Mounted Condenser Configuration

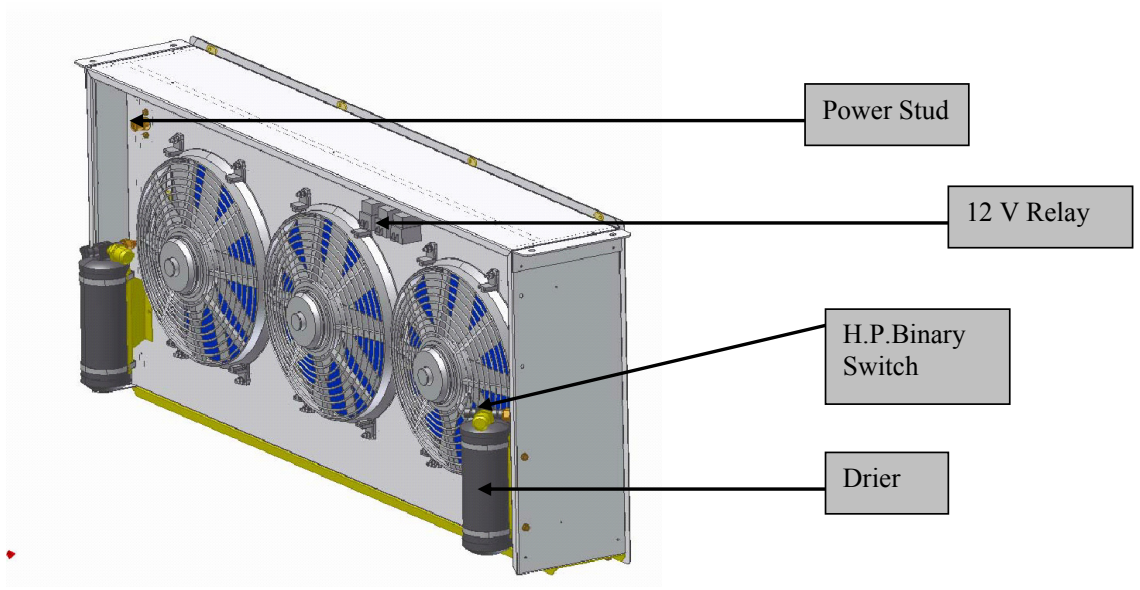
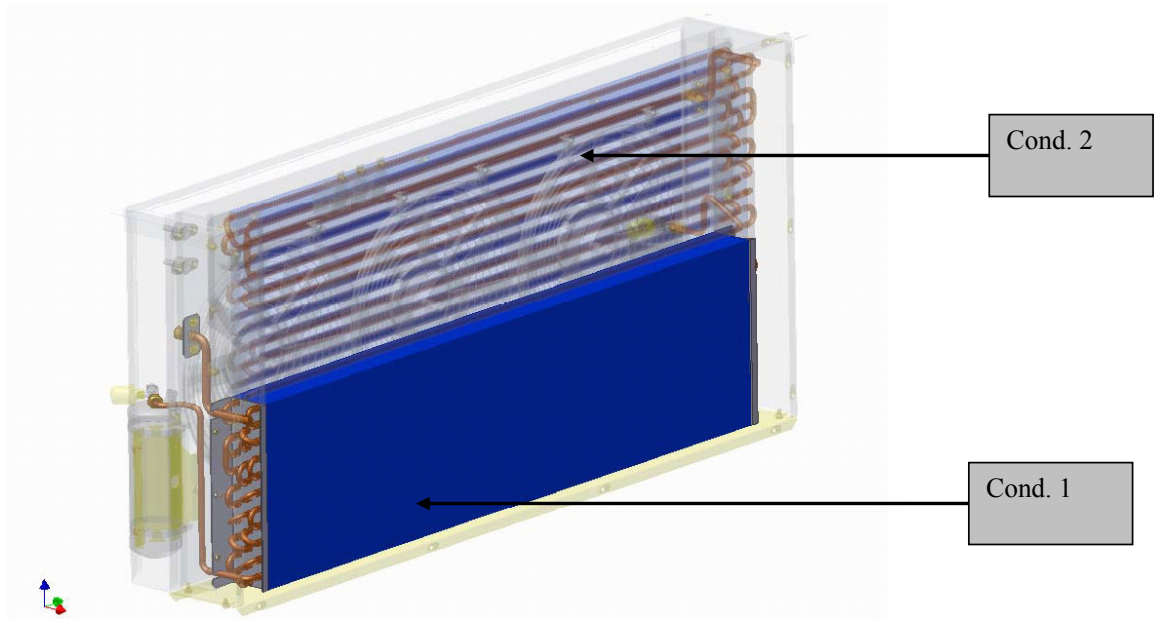

Stacked Skirt Mounted Condenser Exploded View

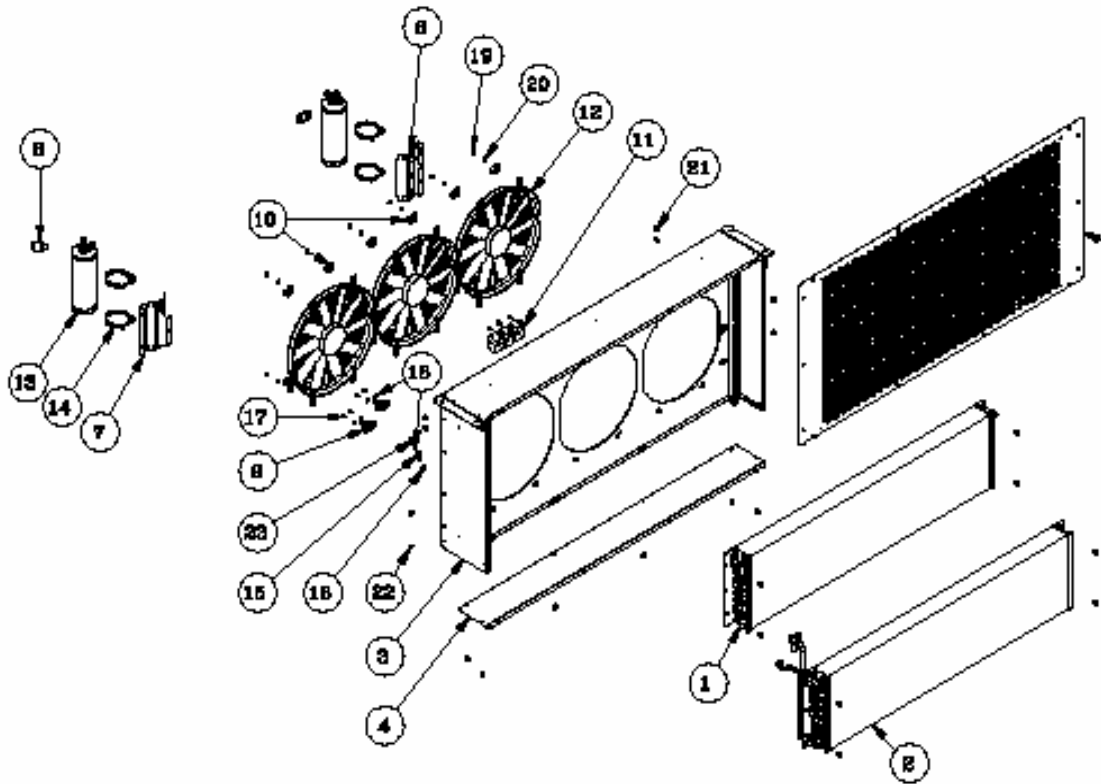

Components

1,2	Coils	4	Condenser Grill
6	H.P. Binary Switch	11	12 V Relays and Base
15	Receiver Drier		



55,000 Bth/hr Free Blow Evaporator Configuration

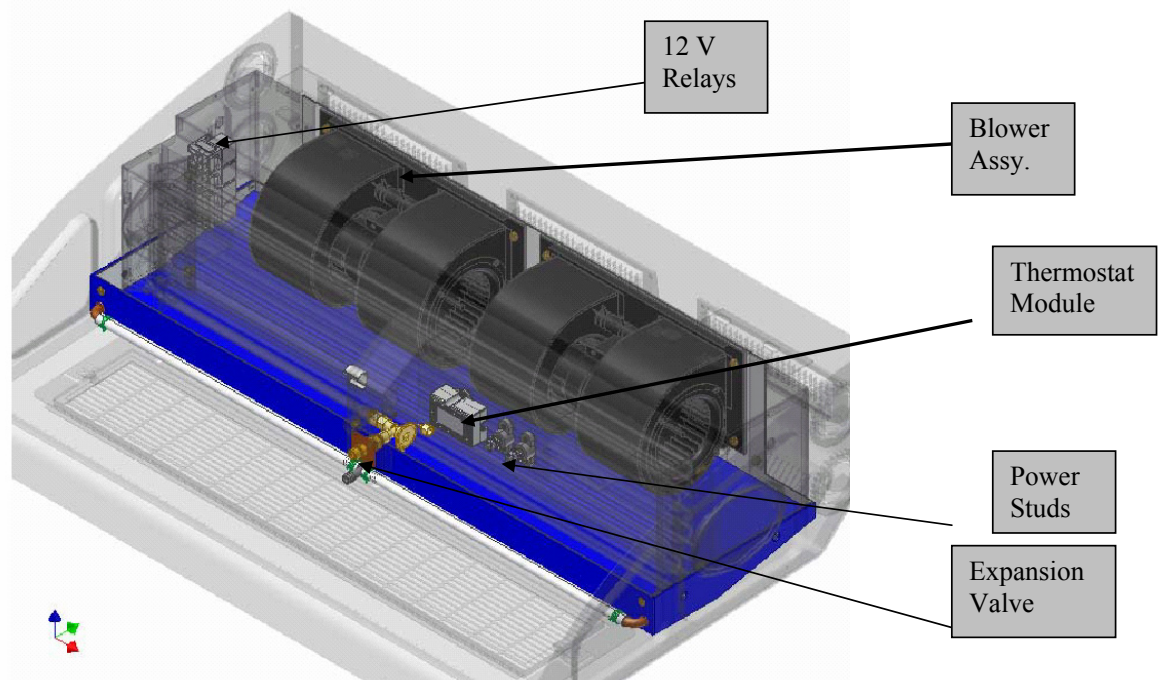
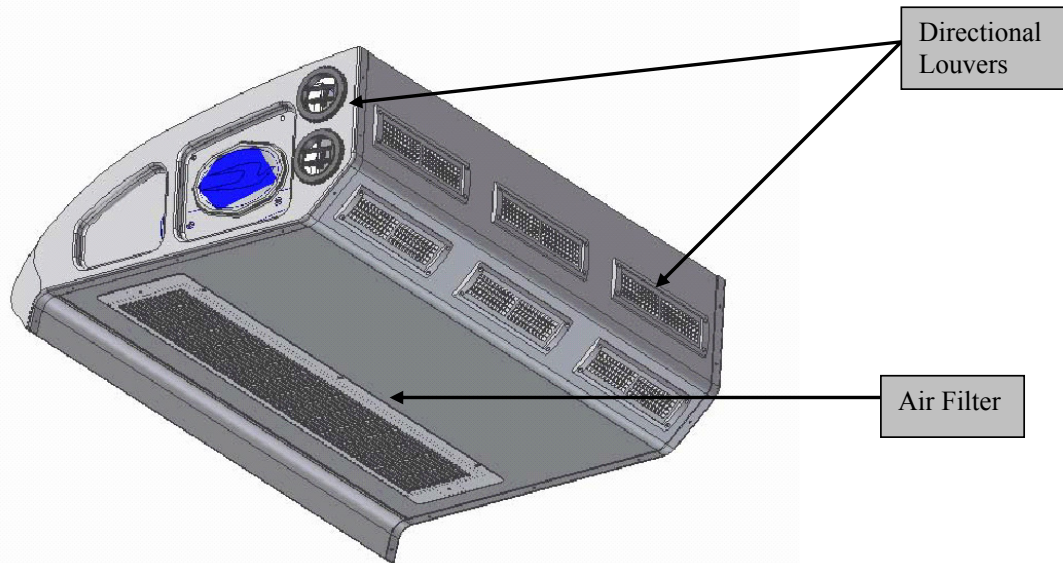

55,000 Btu/hr Free Blow Evaporator Exploded View

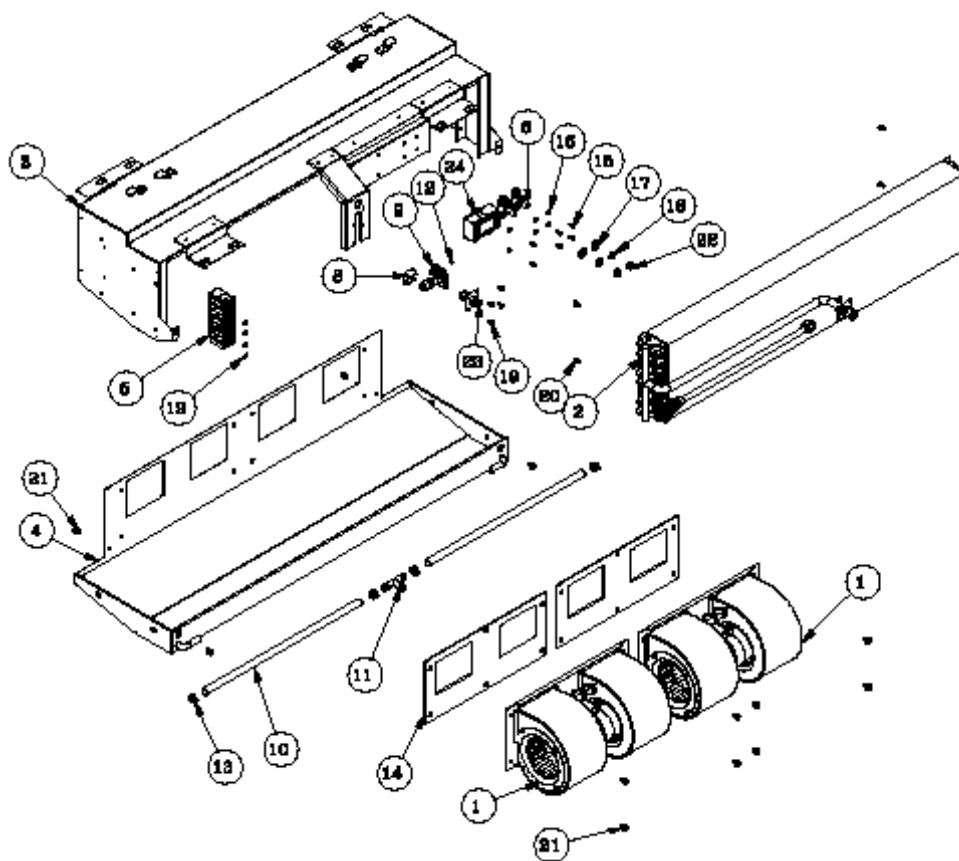

Components

1	Blower Assembly	2	Coil
5	12 V Relays and base	6	Power Stud
9	Expansion Valve	10	Defrost Drain Tube



Typical TM-21 Compressor

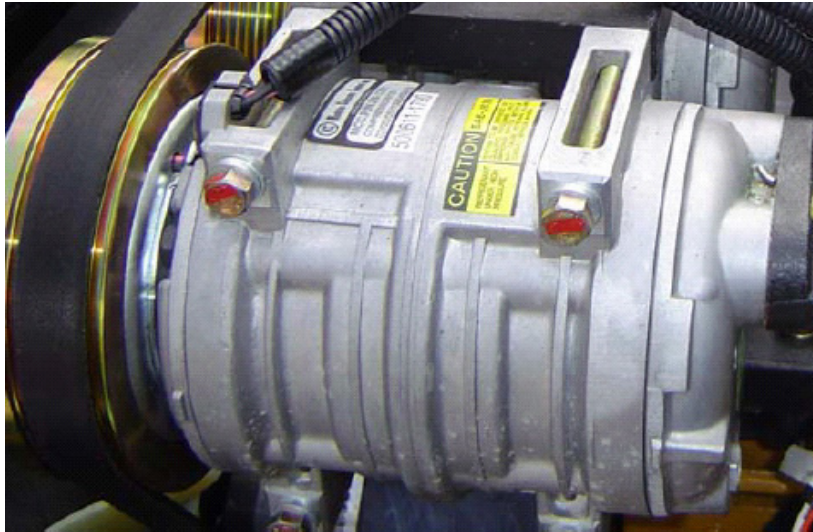

Manual Control Panel



High Pressure Binary Switch

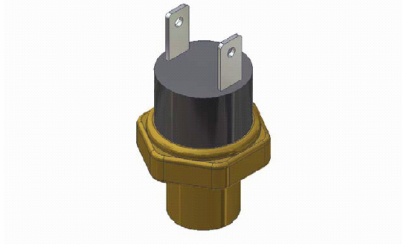

Typically located on or near the receiver drier, when the pressure in the high side of the system reaches 385 psi, the switch will open, disrupting the voltage to the compressor clutch. The clutch will disengage, causing the compressor to stop working preventing serious damage from occurring to the system. The HP Binary switch will then close once the pressure has reduced.

As well, when the pressure on the low side reaches 28 psi, the switch will open, disrupting voltage to the compressor clutch. The clutch will disengage, causing the compressor to stop working.

Electronic Thermostat

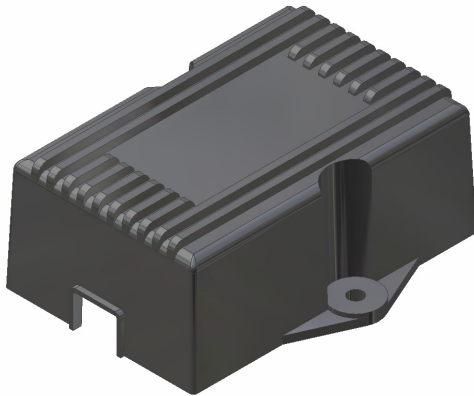

Located inside the evaporator cover, the thermostat serves a temperature control and prevents the evaporator from freezing. The thermostat is designed to open the circuit to the H.P. Binary switch when the evaporator coil reaches 35 – 37 °F.



Driver Instructions and Information

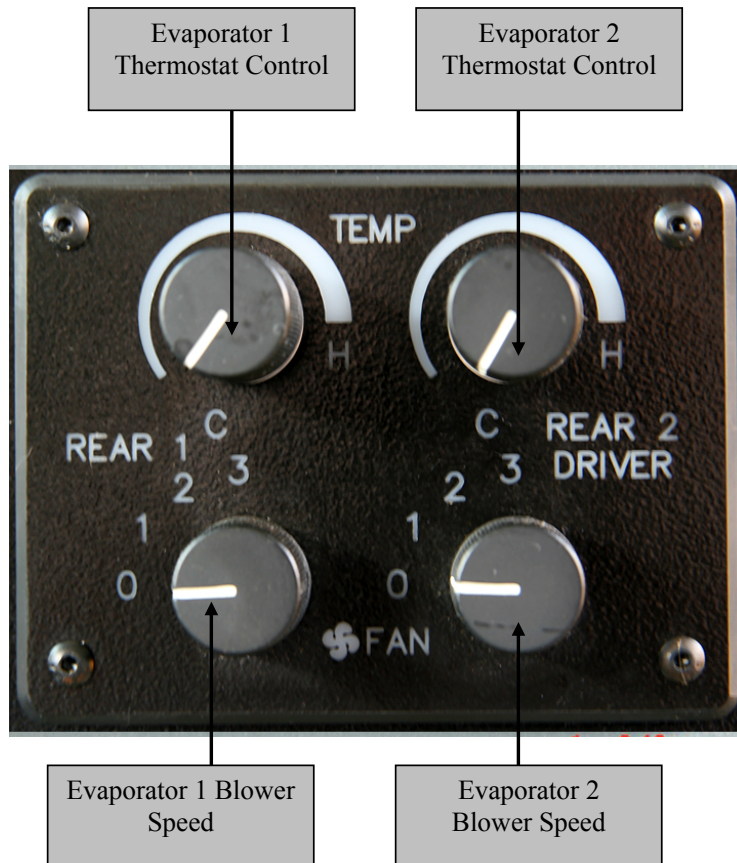

Starting the Unit

1. Start the vehicle, and select both blowers switches to #3 high speed, select the thermostat control switches to full cool (clockwise) towards H. The Micro Bird will have only one Rear Temperature knob and one Fan speed knob on the panel above the driver. The OEM A/C controls will be integrated into the dash.
2. Leave the unit running (if allowed, not legal in some municipalities) with all windows and doors closed for a period of 10 – 20 minutes, to stabilize the temperature of the bus.
3. Driver can control the desired temperature after the bus is loaded, by turning either the blower switch or the temperature control switch to a comfortable level for the passengers.

4. Driver can also direct the air from the evaporators, by positioning the louvers at the evaporator outlets.

Bi Monthly Post Trip Checks

1. Wash Condenser and Evaporator coils.
2. Check for leaks.
3. Check loose or missing hardware.
4. Check for physical damage to the units

NOTE: In Extreme conditions Condenser coils should be washed on a daily basis.

Regular Maintenance by Driver

The recirculation air filter is made of open cell foam and should be cleaned with water. A mild detergent may also be used. It does not require cleaning as frequently as the fresh air intake filter.

The AC system is recommended to be turned on for at least 5 minutes weekly throughout the year to keep internal parts lubricated.

It is generally a good rule to inspect the compressor and drive belt wear (weekly). The condenser should be kept clean and should be checked frequently.

Basic Trouble Shooting for Driver

Note: always be aware of surroundings; be aware of moving and leaking parts.

How cold should the air at the evaporator louver be at 85 °F ambient?

Run the machine for 15 minutes. The air temperature at the louver should be between 36 – 53 °F depending on the amount of humidity in the air.

Is there any noise from the Evaporator Blower motor?

If the fan blower is noisy or does not operate correctly, do not use, bring to technician.

Has mud or dirt adhered to the condenser?

Remove any mud or dirt since this drastically reduces heat radiation. Check the air flow through the condenser. Do not scratch or bend condenser fins.

Is the compressor clutch engaging when A/C is on?



Visually check the center of the compressor clutch to make sure it is spinning with the pulley.

If not call for service, bring it to a qualified repair facility.

Is there any noise from a loose compressor drive belt, or compressor?

Listen for abnormal noises, if suspected; take it to a qualified repair facility.

Is there any compressor oil on hoses, fittings, or around the compressor?

If so, do not operate A/C system and take it to a qualified repair facility.

Is the engine coolant bypassing the heater valve?

Ensure that the heater valve is turned off. Feel the heater line into the heater coil if the line is warm or hot, suggests that the heater valve is leaking.

Technician Instructions and Information

Note: The following procedures involve servicing the air conditioning system. Some of these service procedures are regulated by federal, and in some cases, State and Local laws.

All regulated air conditioning service procedures must be performed by an EPA certified technician, using approved equipment and complying with all, Federal, State and Local Laws.

Charging the Air Conditioning System

These units can be damaged by over charging of refrigerant. The amount of refrigerant the system can hold depends on circuit volume which is affected by hose length. The most satisfactory method of charging the engine driven compressor circuit is:

1. Connect a gauge manifold or charging machine to the compressor service valves.
2. Connect the center hose of the gauge manifold to the manifold of an evacuation pump or station.
3. Connect the hose from a drum of refrigerant to the manifold or evacuation station. Make sure the valve on the drum is closed.
4. Open the valves on the gauge manifold and the evacuation station.
5. Start the vacuum pump and evacuate the system to 500 microns. After the system reaches 500 microns, evacuate the system for an additional hour.

Note: If the system will not pull down to 500 microns, there is probably a leak in the system or one of the evacuation hoses. Find and repair the leak.

6. After the additional hour of evacuation, close the valve at the evacuation pump, stop the vacuum pump, and observe the reading on the vacuum gauge for 5 minutes. The pressure should not exceed 2,000 microns.

Note: If pressure does exceed 2000 microns, repeat steps 4 and 5. This time if the pressure exceeds 2000 microns within 5 minutes, a leak is present in the system or one of the evacuation hoses. Find and repair the leak.

7. Open the vacuum valve at the vacuum pump or evacuation station, and evacuate the system to 500 microns.
8. When the system reaches 500 microns, close the vacuum valve at the evacuation station. The system is now ready to charge.
9. Close the low side valve on the manifold and leave the high side valve open, open the valve on the refrigerant drum to deliver liquid.



10. Allow the correct charge (refer to spec's) to enter the system. Then close the valve on the refrigerant drum and the high side valve on the gauge manifold.

Checking the Refrigerant Charge

If the unit has an insufficient charge, the evaporator will be “starved” and the temperature will rise in the vehicle even though the unit is running. Also, an insufficient charge does not circulate enough oil to properly lubricate the compressor. The charge may be determined with the following conditions established:

1. Install a gauge manifold set or charging station.
2. Run the unit at its coldest setting, blowers on high speed, and all windows and doors closed on the vehicle.
3. The discharge pressure should coincide with the temperature/pressure chart.
4. If pressures are low, check for leaks, if no leaks exist, charge the refrigerant with vapor through the low side.

Checking the Compressor Oil Charge

Generally there is enough oil charge in the compressor to handle a system with a refrigerant charge of 3 lbs. With these systems being larger an additional an additional 5 oz of oil should be added to each system during a charge. The compressor is filled with PAG oil (Poly Alkylene Glycol).

Oil must be added at the suction port on the compressor prior to vacuuming the system, or use an automatic oil injector found on most charging stations.

The other instance when oil may need to be added to the system is when there is a refrigerant leak, or when the evaporator, condenser, or receiver drier need to be replaced, 1 ounce of oil should be added for each component replaced.

Returning oil to the compressor – Open all doors and windows – Turn A/C fan on high – run unit at idle for 20 minutes.

Always measure oil removed and install the same measurement when replacing.

High Pressure Binary Switch

The High Pressure Binary Switch is found on the receiver drier. If the discharge pressure reaches 384 psi, the HP Binary switch de energizes the compressor clutch. Also if high side pressure is below 28 psi, the HP Binary switch will disengage the compressor clutch.

To test a HP Binary switch re-work a gauge manifold high side as shown in the following illustration:

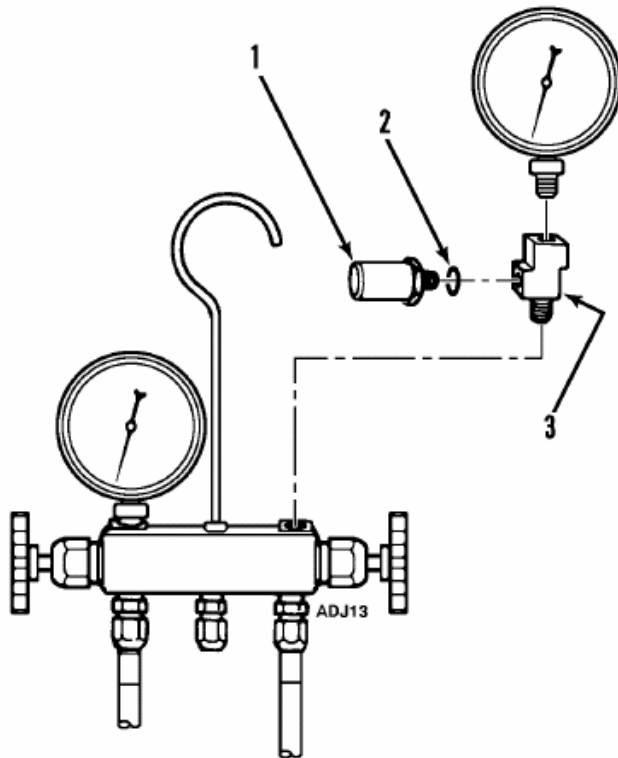

1	Pressure Relief Valve 400 psi
2	O Ring
3	Fitting

1. Connect the gauge manifold to the compressor discharge service valve.
2. Set the thermostat control to the coldest setting.
3. Raise the discharge pressure of the compressor by blocking the air flow through the condenser coil or flipping the condenser breaker in the main electrical panel.
4. Failure of the high pressure cut out system to stop compressor operation should be investigated first by checking the control system and second by replacing the HP Binary Switch.

Note: The discharge pressure must never be able to reach 400 psi on an R134a system.



Clean Up Procedures

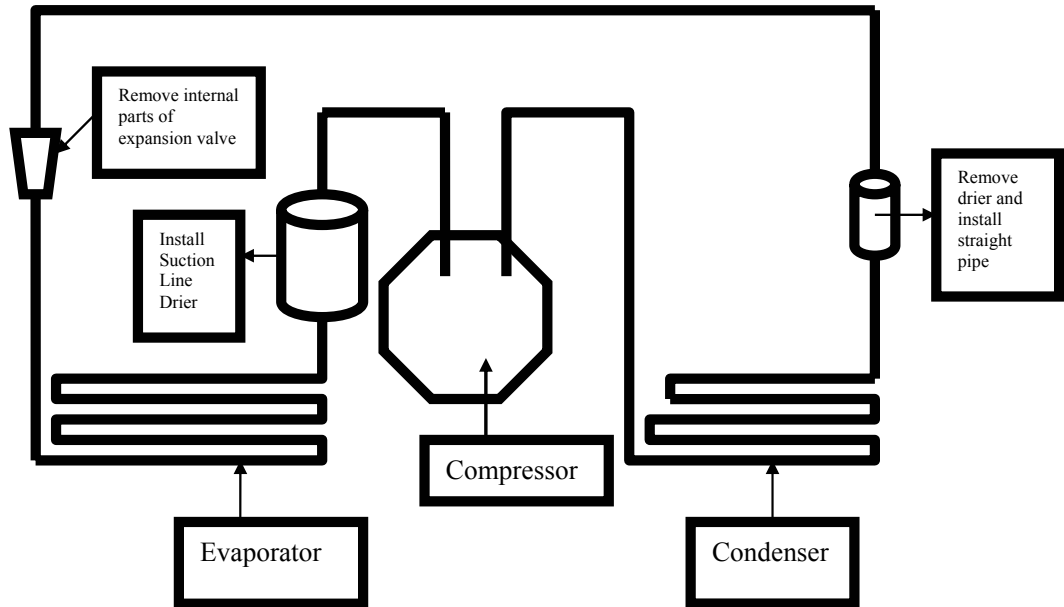

At times it might be necessary to perform a system clean up if the system has been contaminated by a "Burn Out". In order to determine this, an acid test has to be performed on the compressor oil.

If the acid test fails, you will have to install a clean up filter in series with the suction line.

1. Remove all internal parts of the expansion valve, and re assemble valve body,
2. Remove receiver drier and install straight copper pipe or hose to bridge the system.
3. Install suction line clean up drier between the evaporator outlet and the compressor inlet.
4. Check for leaks.
5. Evacuate the system to proper levels.
6. Weigh in proper refrigerant charge and oil charge.

7. Run unit for 2 hours.
8. Stop unit and check oil sample with acid test kit. If the test kit shows there is no acid in the system, you can proceed to reclaim the charge and reassemble unit. If the acid test check fails change the suction line drier and repeat the steps above.
9. Only after the system has past the acid test check can it be put together to its proper running condition.



Part Replacement Procedures

Note: *Is it generally good practice to change the receiver drier whenever the high side or when the low side is opened for an extended period of time.*

Compressor

Removal

1. Remove refrigerant from the system.
2. Loosen all belt adjuster and remove belt from compressor.
3. Disconnect the suction and discharge lines from the compressor.
4. Keep the compressor ports, suction and discharge lines for the compressor covered to prevent contamination
5. Remove the compressor mounting screws. Remove the compressor.

Installation

1. Place the compressor in position and attach all mounting screws and belt.
2. Use belt tension tool and adjust belt tension to proper tension.
3. Connect the refrigerant hoses; pour 2 oz's of PAG oil into the suction line before connecting it.

CAUTION: Avoid over-tightening the compressor fittings as damage to the O-Ring seal and/or the compressor is possible.

Large Fitting – 25 to 30 ft. – lb.
Small Fitting – 18 to 20 ft. – lb.

4. Pressurize the system and check for leaks.
5. Evacuate the system and re charge.

Condenser Coil

Removal

1. Remove the refrigerant from the system.
2. Remove lines that are connected to the condenser and receiver driers.
3. Remove mounting bolts.
4. Drop condenser and remove the condenser grill.
5. Remove screws to casing, remove coil from casing.

Installation

1. Place the coil in the casing and install all mounting screws.
2. Install grill, set condenser unit in place and install mounting screws.
3. Install all lines and tighten fittings.
4. Replace receiver drier.
5. Pressurize system and check for leaks.
6. Evacuate and recharge with refrigerant.

Receiver Drier

Removal

1. Remove refrigerant from system
2. Remove lines from drier.
3. Remove bracket.
4. Remove HP Binary Switch set aside for re-use.

Installation

1. Install existing HP Binary switch you set aside in the previous step.
2. Install drier with new lubricated O Rings in place.
3. Tighten fittings to hoses.
4. Tighten drier bracket.



5. Check for leaks.
6. Evacuate and recharge with refrigerant.

High Pressure Binary Switch

Removal

1. Disconnect wires from the HP Binary switch.
2. Quickly remove the HP Binary switch to allow Schrader on drier to seal system and hold charge.

NOTE: Be very careful not to allow an abundance of refrigerant to escape, if so you must verify refrigerant charge.

Installation

1. Install O Ring.
2. Install HP Binary switch.
3. Install wires to HP Binary switch.
4. Check for leaks.

Evaporator Coil

Removal

1. Remove refrigerant from the system.
2. Remove the evaporator cover
3. Remove the drain pan assembly.
4. Remove the fittings and lines to expansion valve and evaporator outlet.
5. Remove Expansion valve.
6. Remove evaporator mounting screws.
7. Remove evaporator coil.

Installation

1. Position coil and install mounting screws.
2. Install expansion valve and tighten fittings.

3. Install lines and fittings to expansion valve and evaporator outlet.
4. Position and install electronic thermostat with mounting screws.
5. Install lines and fittings to the expansion valve and the evaporator outlet.
6. Install drain tube.
7. Install evaporator cover.
8. Check for leaks.
9. Evacuate and recharge with refrigerant.

Expansion Valve Assembly

Removal

1. Remove refrigerant from system.
2. Remove evaporator cover.
3. Remove drain pan assembly.
4. Remove line and fitting from expansion valve inlet.
5. Remove equalizer line
6. Peel back tape and remove expansion valve feeler bulb from line.
7. Remove fittings at expansion valve.
8. Remove expansion valve.

Installation

1. Position expansion valve and tighten fittings.
2. Install feeler bulb and secure on line.
3. Tape feeler bulb.
4. Position and install equalizer line by tightening fitting.
5. Position and install drain pan assembly.
6. Install evaporator cover.



7. Check for leaks.
8. Evacuate and recharge with refrigerant.

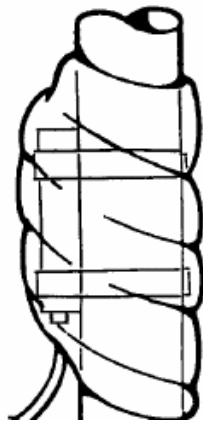
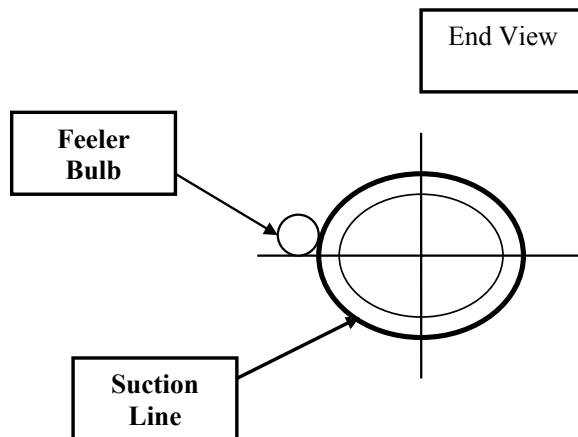

Completely wrap bulb and sensor with tape. Ensure that line and bulb has good clean contact.

Structural Maintenance

Unit Inspection

Inspect the unit on pre trip and regular scheduled maintenance for loose or broken wires and hardware, compressor oil leaks, or other physical damage which might affect the unit performance and require the repair or replacement of parts.

Evaporator Coil

Clean the evaporator coil during scheduled maintenance inspection by blowing compressed air down through the coil and out (opposite the normal air flow). Inspect the coil and fins for physical damage and repair if necessary.

Note: *Air pressure should not be high enough to damage coil and fins.*

Safety Note: *When blowing down, wear safety glasses.*

Condenser Coil

Clean the condenser coil during regular scheduled maintenance by blowing compressed air or washing with mild soap and water down through the coil (opposite the normal air flow). Inspect the coil fins for physical damage and repair if necessary.

Note: *Air pressure and water pressure should not be high enough to damage coil and fins.*

Mounting Bolts

Periodically check and tighten all mounting bolts.



TM-21 & TM-16 Compressor and Clutch Maintenance

Operation

A stationary field coil is mounted on the compressor body eccentric with the shaft. A pulley assembly, consisting of a pulley, disc and hub is mounted on the shaft of the compressor. The hub and disc are flexibly connected with flat springs that when extended hold the disc slightly away from the pulley web (friction Surface).

When an electric current flows through the field coil, a magnetic field is created. The magnetic field pulls the disc against the pulley web and compresses the flat springs. This causes the hub and disk to rotate with the pulley.

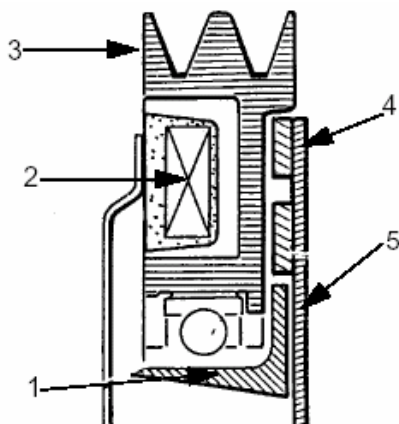

1.	Hub	4.	Disk
2.	Stationary Field Coil	5.	Flat Springs
3.	Pulley		

Compressor Clutch Assembly

Inspection

1. **Drive Plate:** If the contact area is scorched, the drive plate and pulley should be replaced.
2. **Pulley Assembly:** Inspect the appearance of the pulley assembly. If the pulley's interior contact surface is extremely grooved due to slippage,

both the pulley and the drive plate must be replaced. There should also be no foreign matter, such as oil or grit, lodged between the drive plate and pulley. Thoroughly clean these contact surfaces and the drive plate.

3. **Coil:** Inspect the coil for a loose connector or cracked insulation. If the insulation is cracked, replace the coil. Repair or replace the wire or connector if either is loose or damaged.

Clutch Removal

Note: Make sure the proper tools are available before performing maintenance procedure.

1. Remove the center bolt using the puller arbor to prevent drive plate rotation.

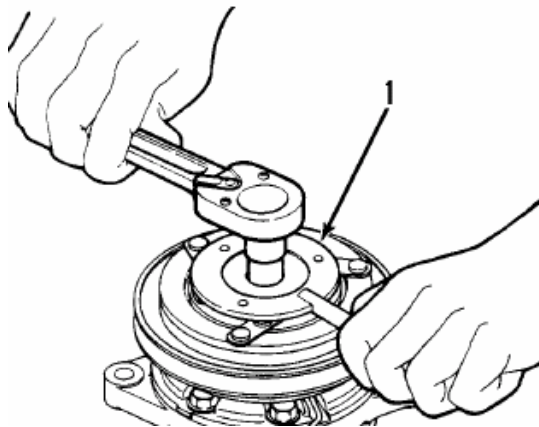

2. Remove the drive plate by using the shaft seal kit. Then remove the shims from either the driveshaft or the drive plate.

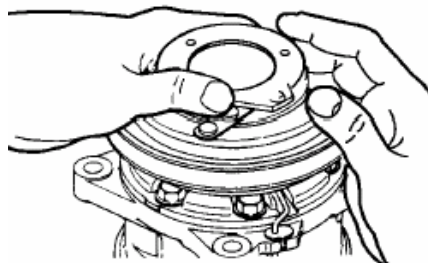

3. Remove the snap rings using external snap ring pliers.



4. Remove the cover.

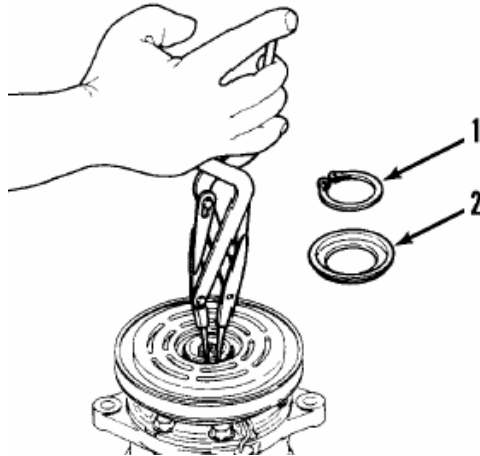

1.	Snap Ring
2.	Cover

Remove Snap Ring and Cover

5. Remove the pulley assembly by using the clutch remover and the spacer positioned on the cylinder hub.

Note: To avoid damage to the pulley groove, the pulley claws should be hooked (under) the pulley groove.

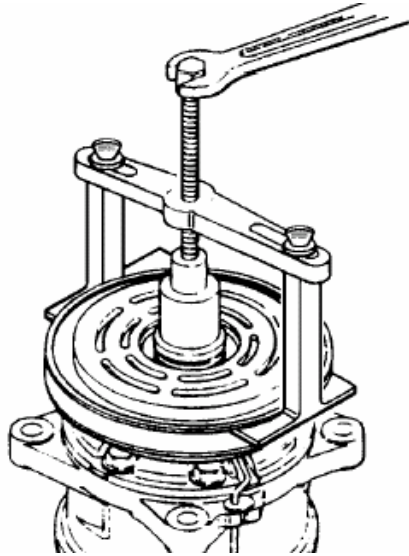

6. Remove the coils lead wire from the holder on the compressor.
7. Remove the three screws that attach the coil to the compressor and remove the coil.

Clutch Installation

1. Confirm the felt is installed on the front of the cylinder head.
2. Install the coil on the compressor (with the lead wire on top). At this time confirm the coil's concave portion is aligned with the felt then tighten the screws to the proper torque specifications.

Note: Specified Torque: 2.9 to 4.3 ft-lbs.

3. Install the lead wire in the wire holder on the compressor.

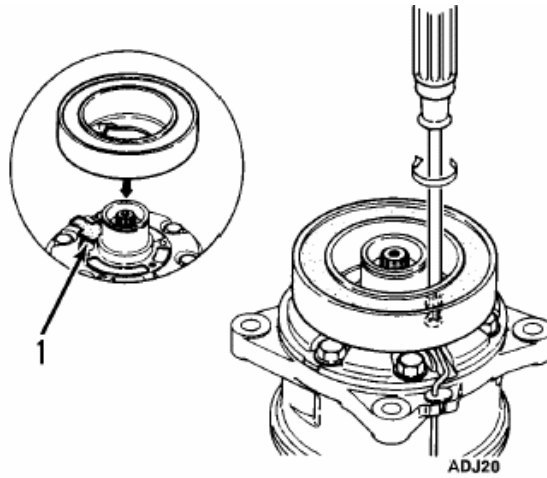

1.	Felt
----	------

Install Coil

4. Install the pulley assembly and using the compressor holder and press.

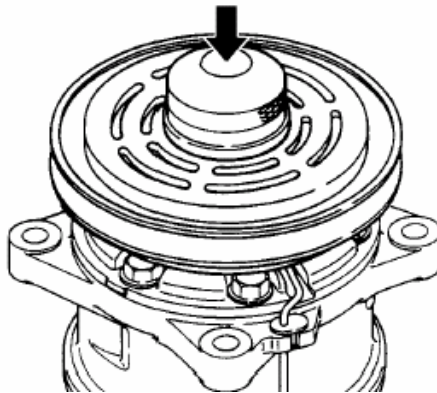

5. Install the cover and the snap ring using external snap ring pliers. **Make sure the chamfered inner edge of the snap ring must face upward.**

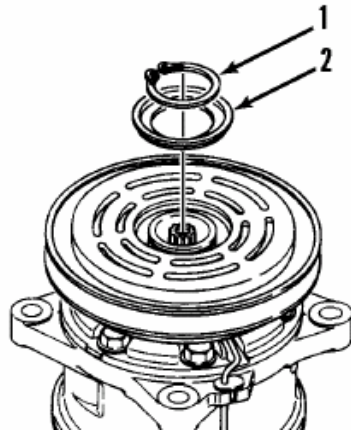

1.	Snap Ring
2.	Cover

Install Cover and Snap Ring

6. Install the driver plate on the drive shaft, together with the original shim(s). Press the drive plate down by hand.
7. Tighten the bolt to the required torque specifications using the puller arbor to prevent drive plate rotation. Torque bolts to **8.7 – 10.1 ft. lbs.** After tightening the bolt, ensure that pulley rotates smoothly.

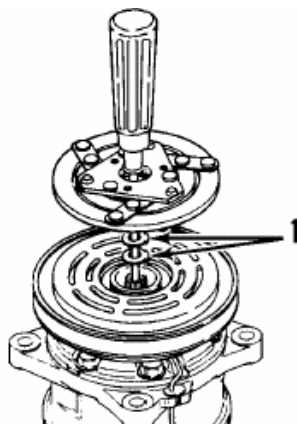

1.	Shims
----	-------

Install Shims and Drive Plate



8. Ensure that clutch clearance is as specified. If necessary, adjust the clearance using shims. Specified clearance is 0.01 to 0.02 in. (0.3 to 0.6mm)

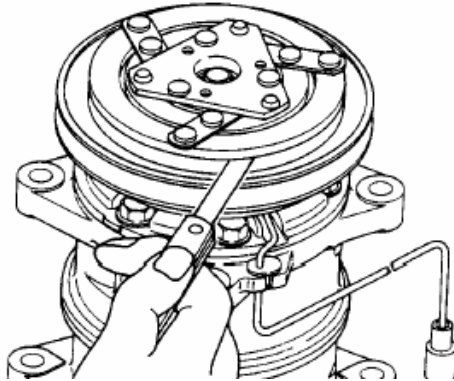

Electrical Connection

1. Connect the lead wire to the electrical circuit.
2. Engage and disengage the clutch several times to check the clutch engagement. The disc should snap firmly against the pulley.

Compressor Front seal Removal and Installation

Removal

1. Remove the clutch as outlined in Clutch Removal.
2. Remove the felt pad.
3. Use the seal remover to remove the shaft seal cover. Turn the seal remover to engage on the hook on the seal remover with the hook on the shaft seal cover, and then slowly pull the seal cover out of the cylinder head.

Note: *The shaft seal cover should never be reused, always replace the cover with new one.*

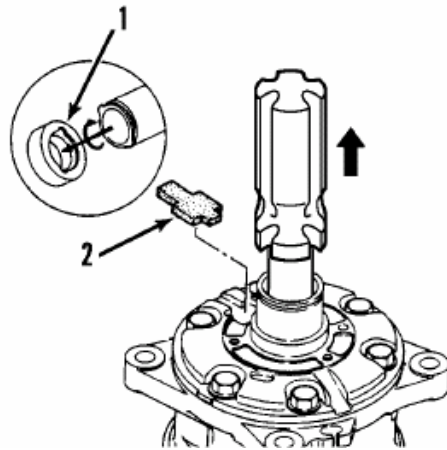

1.	Shaft Seal Cover
2.	Felt Pad

4. Use the seal remover to remove the shaft seal. Turn the seal remover to engage the hook on the seal remover with the hook on the shaft seal, and then slowly pull the seal out of the cylinder head.

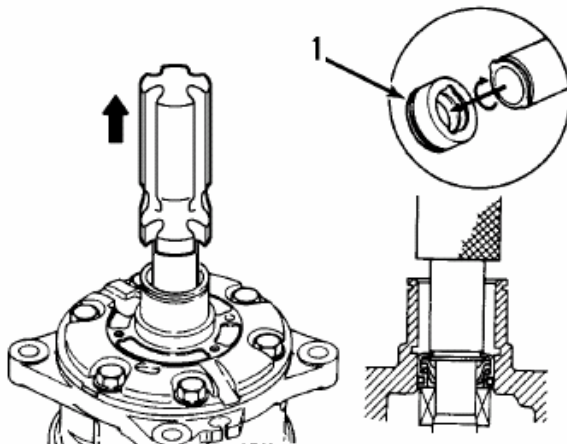

1.	Shaft Seal
----	------------



Inspection

The shaft seal must never be reused. Always use a new shaft seal when reassembling a compressor. Be extremely careful to make sure the lip of the shaft seal that is being installed is not scratched or damaged in any way. Make sure the shaft seal is free of lint and dirt that could damage the shaft seal surface.



Inspect Shaft Seal

Installation of Shaft Seal

1. Clean the front section of the cylinder head that holds the front seal.
2. Apply clean PAG compressor oil to the shaft seal and to the front cylinder head. If the slip surfaces are dirty, clean them with thinners, dry the clean surfaces and apply clean PAG compressor oil.
3. Place the seal on the seal guide and slide the seal into the cylinder head.

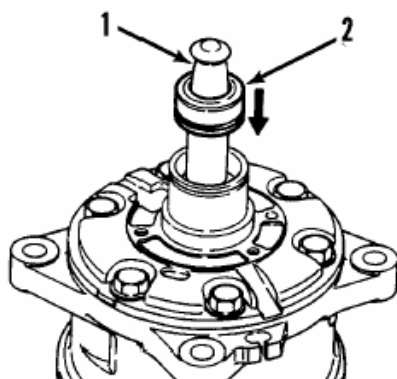

1.	Seal Guide
2.	Shaft Seal

Place Shaft Seal on Guide

4. Use the seal installer to press the shaft seal into the cylinder head as far as possible.
5. Remove the seal guide from the shaft.

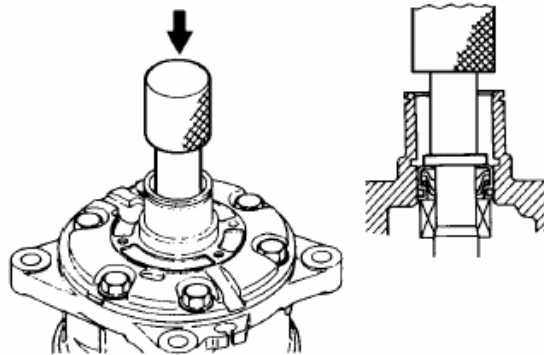

6. Place the seal guide on the end of the shaft.
7. Place the shaft seal cover on the seal guide and slide the shaft seal cover into the cylinder head.

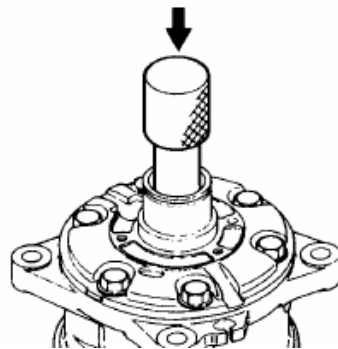

8. Remove the seal guide from the shaft.

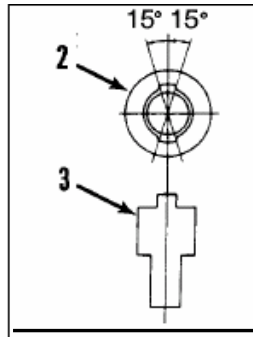
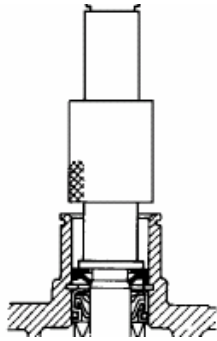

System Compressor and Oil Handling

Installation of the Compressor

The compressor(s) is mounted on the under side of the engine. The side to side mounting of the compressor must remain 45 degrees from the horizontal. The forward and backward angle should be 10 degrees of horizontal. Access to the air conditioning service ports is under the driver's side midway of the vehicle.

Each compressor comes with a standard charge of 5 oz. of PAG compressor oil. This quantity of oil is enough to install the compressor on a system that has oil already in it. New systems require that the proper amount of oil be added to the system.

During normal operation of the system, there is always oil traveling throughout the system. The oil lubricates all the components in the systems and returns back to the compressor, and then back into the system.

Major Loss or Refrigerant

In a major refrigerant leak, we can assume that a fair amount of oil will be lost in the system. The oil level should be verified by following the next steps (checking compressor oil level).

Checking the Oil Level

Remove the compressor, and drain the oil by removing the drain plug and from the other ports. Cycle the compressor cylinders by turning the clutch by hand, and drain the oil again. Repeat until all the oil is drained from the compressor. Measure the oil in liquid ounces, also, inspect the oil for contamination.

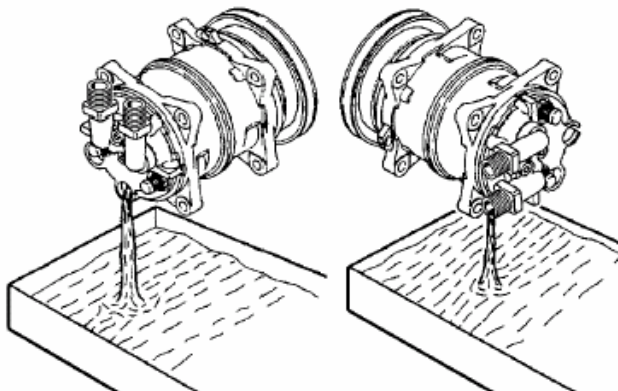



Oil Contamination

1. Dirt in the oil.
2. Color changed to a varnish color.
3. Presence of foreign substances, metal shavings, etc. in the oil.

When a system becomes contaminated

A Severely contaminated system may be indicated by black oil in the compressor. If severe contamination occurs, it will be necessary to flush the entire system. If flushing is required, use industry approved materials.

In all cases when this occurs, you must determine the extent of the contamination. Do this by removing the receiver drier and determine if the black oil has reached the drier. If it is flushing the system is mandatory.

If the oil appears clean at the drier, replace the drier and replace the compressor together with clean new oil.

Electrical Connection

1. Connect the lead wire to the electrical circuit.
2. Engage and disengage the clutch several times to check the clutch engagement. The disc should snap firmly against the pulley.

Clutch Test

1. If the field wire is broken, replace the wire.
2. Check the amperage and voltage. The amperage range should be 3.6 to 4.2 amps. At 12 volts.
 - a) A very high amperage reading – short in the field coil.
 - b) No amperage reading – an open circuit in the windings
 - c) An intermittent or poor system ground results in lower voltage at the clutch. Check for tight fit of the coil retaining snap ring or coil retaining screws for a good ground.
 - d) Replace field coil if it has an open or short circuit.
3. Air Gap - an incorrect air gap could cause erratic engagement or disengagement and/or clutch rattle. Check air gap with feeler gauge (0.1 – 0.02" or 0.3 – 0.6mm) adjust per clutch installation section.

Belt Tensions

Engine Compressor Belts and Pulleys

Correct pulley alignment and proper belt tension are very important when installing a compressor. The compressor clutch must line exactly with the engine pulley and other auxiliary idler or belt adjustment components. When installing the clutch, make sure that the shaft drive key is in place and properly tightened. Check the pulley alignment; make sure that the grooves align properly. Double check by making sure the belt runs from pulley to pulley in perfect alignment and no indication of a sideward bend.

Please see appendix # 2 for the appropriate compressor mount kit install manual. At the top of each manual front page is a description of the engine this kit was designed for, carefully select the engine you are working with. Inside each manual there are step by step photo illustrated instructions for install of the compressor mount kit. Of particular importance to the technician is proper alignment of the six groove belts on eight groove pulleys.

Single V-Belt – Cat C7 A3RE/FE

Adjust the belt tension to 120 lbs. Check belt tension again after 36 hrs. of running, the belt will stretch slightly in first few hours of operation. The belt should not stretch any more after its initial seating period. Loose belts could cause problems with compressor clutch operation and the life of the belt.

Poly V-Belt - Some A3RE/FE, All BBCV and All MicroBird

As with the conventional V Belt drives, correct pulley alignment and proper belt tension are very important. Some buses configurations utilizes a Poly V-Belt drive with automatic tensioner. With the automatic tensioner no adjustment is required as the tensioner will maintain proper tension on the belt at all times. Please refer to the engine specific compressor mount manual for positioning of poly v-belts.



General Trouble Shooting by Technician

Blower Motor Does Not Operate

Possible Cause	Inspection	Solution
1. Blown Fuse	Inspect fuse/wiring	Replace fuse/wiring
2. Broken wire or bad connection.	Check the fan motor for ground and connections.	Repair wiring or connector
3. Fan motor malfunction	Check the lead wires from the motor with a circuit tester	Replace Motor
4. Fan motor switch malfunction	Check power into and out of the switch	Replace fan switch.

Blower Motor Operates Normally, But Air Flow is Insufficient

Possible Cause	Inspection	Solution
1. Evaporator inlet obstructed	Check evaporator for obstruction	Remove obstruction and clean fins with air or water
2. Defective thermo switch, (frozen Evaporator)	Check thermostat using a circuit tester	Replace thermostat

Insufficient cooling, does not operate at all, or operates improperly

Possible Cause	Inspection	Solution
1. System low on refrigerant	The high side pressure will be low.	Repair any leaks evacuate and charge.
2. Excessive Refrigerant	The high side pressure will be high	Recover refrigerant and weigh in correct charge

The compressor does not operate at all, or operates improperly

Possible Cause	Inspection	Solution
1. Loose drive belt	The belt is vibrating, slipping	Adjust tension
2. Internal compressor malfunction	The compressor is locked up and the belt slips	Replace compressor
3. Low battery voltage	Clutch slips	Inspect charging battery charging system
4. Faulty coil	Clutch slips	Replace clutch
5. Oil on the clutch	Clutch slips	Replace or clean clutch surface
6. Open coil	Clutch does not engage	Replace clutch
7. Broken wiring or poor ground	Clutch will not engage	Inspect ground and connection and repair
8. Wiring Harness components	Test the conductance of the HP Binary Switch, thermostat, etc	Repair or replace parts

Gauge Pressure Related Troubleshooting

Normal compressor suction (low side) and discharge (high side) pressures at ambient temperature of 86 – 95 degrees F (30 – 38 degrees C) and compressor speed of approximately 3300 rpm are:

High Pressure: 210 – 300 psi

Low Pressure: 15 – 33 psi

As a rule of thumb the high side pressure will be around 8 times greater than the low side pressure.

Possible Cause	Inspection	Solution
Low Pressure side too high.	The low pressure side normally becomes too high when the high pressure side is too high. As this is explained below, the following inspection is only used when the low pressure side is too high.	
1. Expansion valve opens too far.	Frost is present on the suction hose.	Replace expansion valve
2. Defective compressor.	The high and low pressure side gauge equalize when the magnetic clutch is disengaged.	Replace the compressor.
Low pressure side too low		
1. Low refrigerant charge	The high side pressure will be low and bubbles may be present in the sight glass on the receiver drier	Repair any leaks and recharge the refrigerant to the correct level
2. Restriction between drier and the expansion valve.	Frost on the line between drier and the expansion valve. A negative low pressure reading may be shown.	Flush system or replace hose.
3. Thermostat malfunction	The evaporator is frozen	Adjust probe placement, or replace thermostat
High Pressure too high		
1. Poor condenser performance	Dirt or clogged condenser fins	Clean Fins
2. Excessive refrigerant	The high pressure side will be too high, above 325 psi	Use refrigerant recovery equipment to capture excess refrigerant. Charge to the correct level.
3. Excessive oil	The high pressure side will be too high	Evacuate system. Remove the oil from the compressor and the condenser. Measure oil from compressor and add correct oil charge back to compressor. Flush system with nitrogen. Replace drier.
4. Air in system	Pressure is high on both high and low sides	Evacuate and recharge with refrigerant



5. Restriction in drier, condenser, or high pressure line	High pressure side will be high, and low pressure side will be low.	Evacuate and flush system replacing defective parts
High pressure side too low		
1. Low refrigerant charge	The high pressure side will be low, and bubbles may appear in the sight glass at the receiver drier.	Repair any leaks and recharge the refrigerant to the correct level.
2. Compressor not pumping	Equal high and low pressures	Replace the compressor

Operation to Return Oil to the Compressor

1. Open All Doors and windows
2. Turn on A/C fan on high
3. Run Machine at Idle for 20 minutes

Electrical System Trouble Shooting

Clutch Not Engaging: Power is supplied to the clutch from the blower switch, to the electronic thermostat and through the H.P. Binary Switch to the compressor.

The blower switch must be turned on to a selected speed before voltage is supplied to the electronic thermostat.

Check all connections for proper contact and voltage readings.

Condenser Fans not Operating: R1, R2 and R3 relays are energized by the blower switch at the dash. Once the relay receives 12V, it will energize through pin 86 and close the contacts. Power will flow out of pin 87 and send 12V to the Condenser fan motor. Power will also flow from the electrical box through the circuit breaker to pin 30 of the relay.

Check all connectors for proper contact; ensure that the ground circuit is complete. Check for correct voltage.

Note: 2 diodes are supplied in these circuits to protect the electronic thermostats; these two diodes can be found in the condenser wiring harness at the 6-way connector wire #'s 19 and 20.

Evaporator Fans not Operating Low Speed: Power is supplied to the R4 relay when the blower switch is set to the low (first) Position. The R4 relay energizes and sends voltage through pin 87, to and through the ceramic resistor to the evaporator motors. Power is also supplied from the electrical box through the circuit breaker to pin 30 of the relay.

Evaporator Fans not Operating Medium Speed: Power is supplied to the R3 relay when the blower switch is set to the Medium (second) position. The R3 relay energizes and sends voltage through pin 87, to and through the ceramic resistor to the evaporator motors. Power is also supplied from the electrical box through the circuit breaker to pin 30 of the R3 relay.

Evaporator Fans not Operating High Speed: Power is supplied to the R2 and R1 relay when the blower switch is set to the High (third) position. The R2 and R1 relay energize and send voltage through pin 87, to and through the ceramic resistor to each evaporator motor. Power is also supplied from the electrical box through the circuit breaker to pins 30 of both relays.

Check all connectors for proper contact; ensure that the ground circuit is complete. Check for correct voltage.



Compressor Trouble Shooting

1. Excessive Heat Load such as running the compressor with the doors and windows open will increase incidence of compressor failure. Poor door and window seals or loose parts, can also contribute to premature failure.
2. Dirt on the condenser and evaporator coils will restrict air flow causing capacity loss.
3. Incorrect belt tension will not turn the compressor at proper speed and too tight a belt will cause premature failure on clutch and bearings.
4. Shortage of refrigerant, check and repair leaks.
5. Faulty expansion valve – high superheat will cause low suction pressure, and low super heat will cause high suction pressure.
6. Excessive oil in the system will result in a lower than normal suction pressure reducing capacity.
7. Moisture in the system.
8. Expansion valve loses its charge the system runs in a vacuum.
9. Air in the system will cause high head pressure.
10. Dirt in the expansion valve screen will cause low suction pressure.
11. Ice on the evaporator coil will restrict air flow.

Refrigeration Diagnosis Chart

Unit Not Heating	Rapid cycling	High Head Pressure	Low head pressure	No head pressure	High suction pressure	Low suction pressure	Unit operating in a vacuum	Sigh glass / Empty	Suction Line frosting back	Noisy compressor	Unit not cooling	SYMPTON
												POSSIBLE CAUSES
		•								•		Over charge of refrigerant
			•	•		•	•	•				Sortage of refrigerant
			•	•			•	•	•	•		No Refrigerant
		•										Air through condenser too hot (ambient)
		•										Air flow through the condenser restricted (dirty)
			•			•						Air through the condenser too cold (ambient)
		•									•	Air in refrigerant system
		•										Condenser fan fins bent or broken
	•											Air short cycling around the evaporator coil
						•	•	•				Air through the evaporator restricted
				•							•	Evaporator needs defrosting (iced up)
												Broken compressor belt
						•						Too much compressor oil in the system
												Loose compressor pulley
												Compressor bearing loose or burnt out
				•								Broken valve plate in the compressor
						•	•					Expansion valve power element lost its charge
						•						Expansion valve feeler bulb improperly mounted
						•			•			Expansion valve feeler bulb not making poor contact
						•			•			Expansion valve open too much
												Expansion valve closed too much
						•			•			Expansion valve needle eroded or leaking
			•			•	•					Expansion valve partially closed by ice or dirt
•												Coolant valves not open
•												Truck engine not running
					•				•	•		Liquid refrigerant entering compressor
						•	•					Restricted line on low side
		•					•					Restricted line on high side
							•					Restricted drier
			•									Reverse fan rotation
												Loose or broken electrical connections
						•	•	•				Gauge out of calibration
		•										Condenser fan motor not operating
						•	•		•	•		Evaporator fan not operating



System Service and Maintenance Notes

Service Guidelines

Routine maintenance such as cleaning filters and checking the compressor belt tension are procedures that should be included in the driver pre-use inspection.

However, only trained HVAC technicians should perform air conditioning service for mobile equipment. Proper HVAC tools and equipment is an absolute necessity to ensure the service is performed correctly.

Along with using a trained HVAC technician, there are simple service rules that should be followed during an initial installation or during service repair work.

Compressor Oil Charge

This is often a topic of many opinions. Generally there is enough oil charge in the compressor to handle a system with a refrigerant charge of 3lbs. With these systems being larger an additional 5oz of oil must be added to each system during an installation.

The compressor is filled with PAG oil (Poly Alkylene Glycol).

To retain a valid warranty on the compressor, Seltec ZXL 100 PAG oil must be used. Add the oil on the suction port on the compressor prior to vacuuming the system, or use the automatic oil injector found on most refrigeration charging stations.

Component Replacement and Refrigeration Leaks – The other instance when oil may need to be added, is when there is a leak in the evaporator, condenser, or the receiver drier needs to be replaced, 1 ounce of oil should be added for each component replaced.

If there is a refrigerant leak, the system should have the remaining refrigerant evacuated. The best way to determine where the leak is located is to charge the system with dry nitrogen. Use a spray bottle filled with a mixture of soap and water to spray on all of connections to find where the leak is occurring. Most charging stations also have the ability to inject leak detection fluid and then use a light or sniffer to determine where the leak is.

Once the leak is found, replace and correct the leak or part. **Also, whenever the system is opened to the atmosphere or there has been a leak in the system, the receiver drier must be changed.**

Generally the air conditioning system is very sensitive to any contaminants or non condensable's, such as dirt and moisture. Extra care is required when installing or servicing the air conditioning system to eliminate the possibility of contaminants entering the system.

Never leave hose fittings, compressor fittings, or components uncapped. Dirt and moisture will harm the system performance very quickly and this is the number one cause for compressor failure. Most compressor failures **never receive warranty** due to contamination in the system.

When installing, or servicing air conditioning components, only new or properly cleaned components should be used. **Before charging the system with refrigerant, the system should be pulled into a vacuum for a minimum of 45 minutes.** This will allow for any moisture in the system to be removed.



Refrigeration Chart

Normal Evaporator Range

Off Coil Air Temp	PSI
26	15.69
28	17.04
30	18.43
32	19.87
34	21.35
36	22.88
38	22.47
40	26.10
42	27.79
44	29.52
46	31.32
48	33.17
50	35.07
52	37.03
54	39.05
55	40.09
60	45.48
65	51.27
70	57.47
75	64.10
80	71.19
85	78.75
90	86.80
95	95.40
100	104.40
101	106.30
102	108.20

Normal Condenser Range

Outside Air Temp	PSI
53	110.20
54	112.10
55	114.10
60	124.30
62	128.50
64	132.90
66	137.30
68	141.90
70	146.50
72	151.30
74	156.10
76	161.10
78	166.10
80	171.30
82	176.60
84	182.00
86	187.50
88	193.10
90	198.90
95	213.70
100	229.40
105	245.80
110	263.00
115	281.10
120	300.10
125	320.00
130	340.80

Range show in **Bold**

1g. WIRING SCHEMATIC-MICROBIRD

MICRO BIRD – MANUAL - TM 16 (Dwg.-P1- 14839)

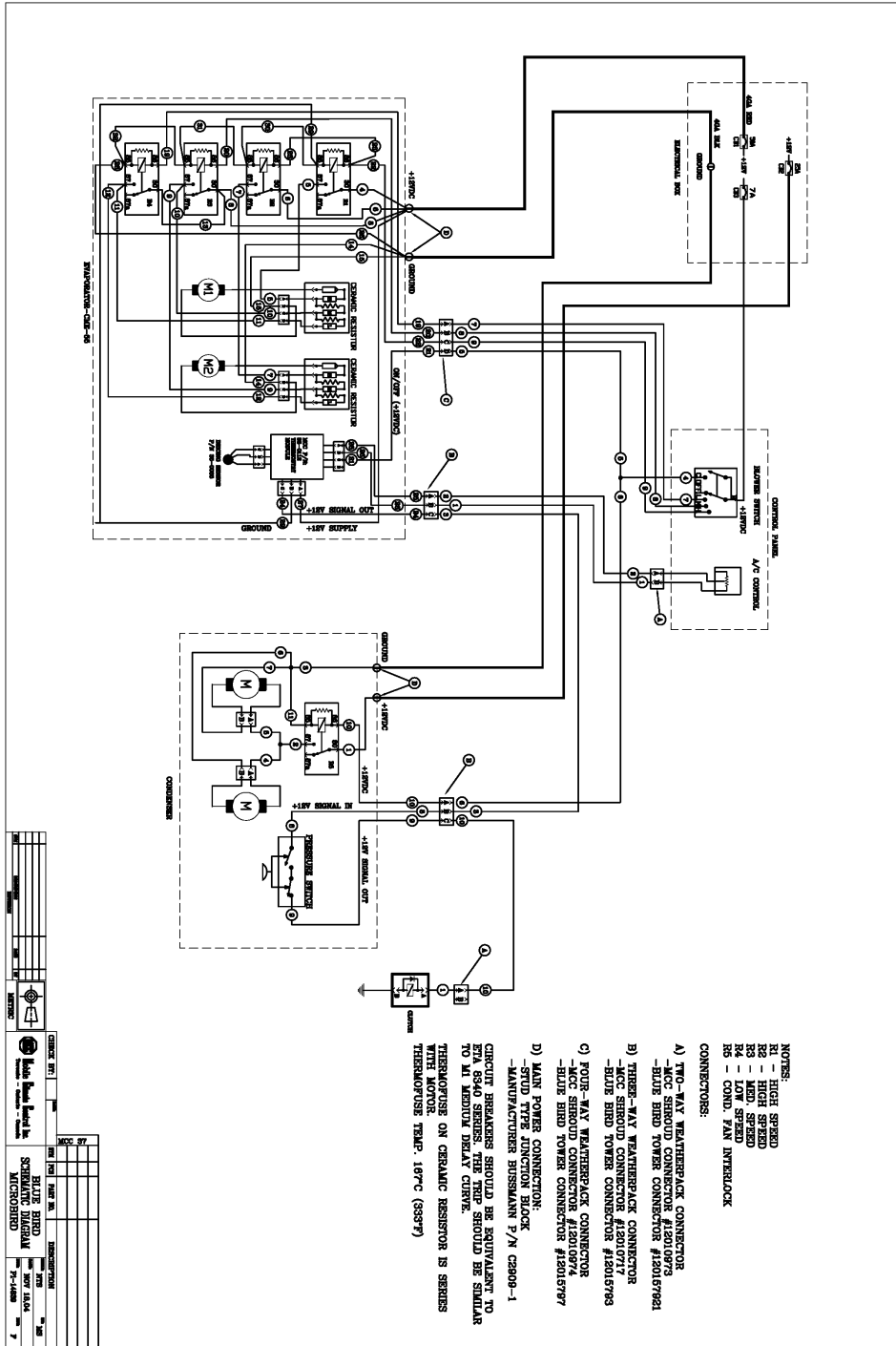



1h. WIRING SCHEMATIC- MICROBIRD

MICROBIRD - ECC - TM16 (Dwg. P1-14852)

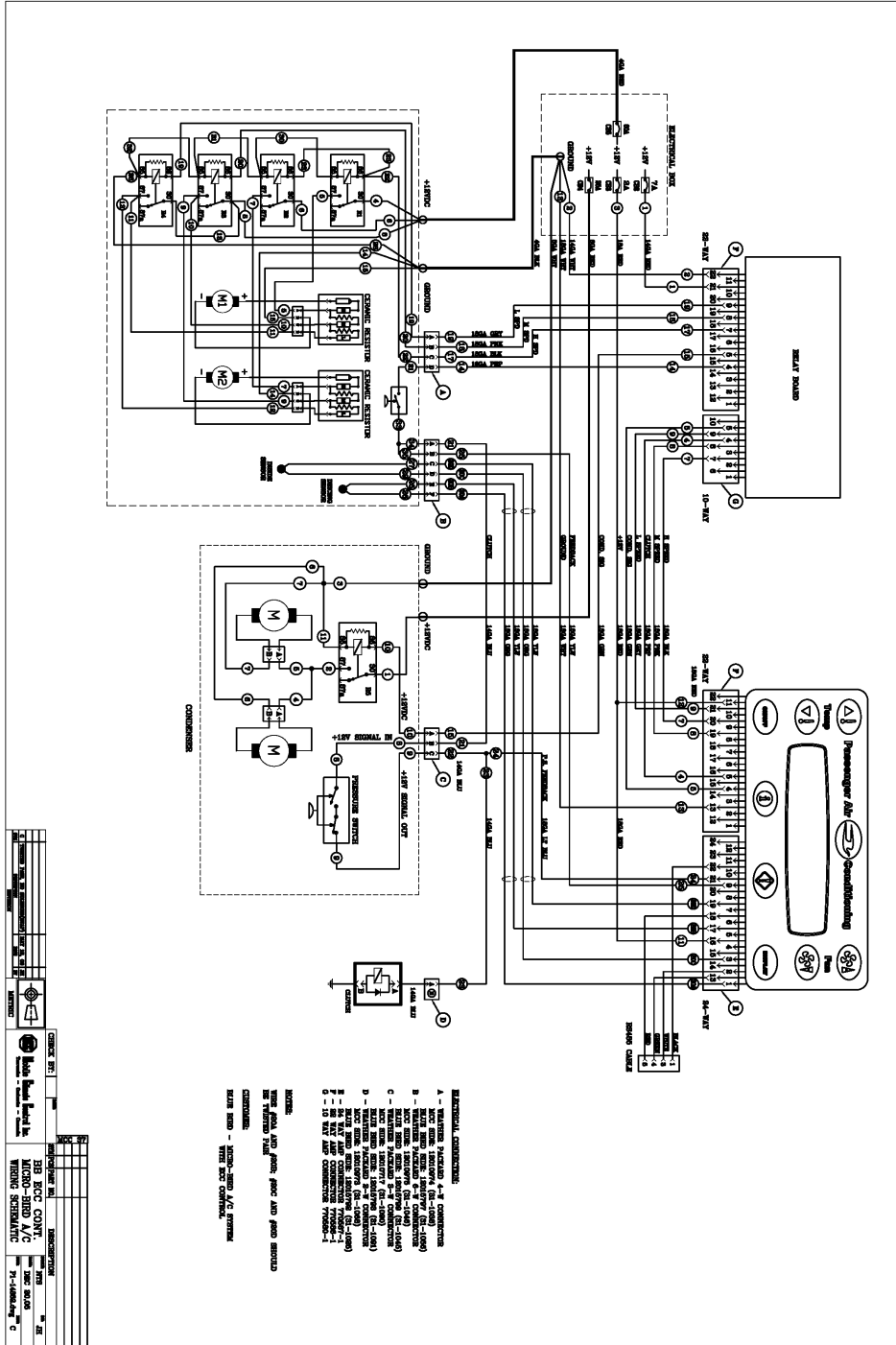

2u. WIRING SCHEMATIC- (P1-14838)
BBCV,A3RE ,A3FE – MANUAL-2TM21-SPLIT-SKIRT MOUNT COND.

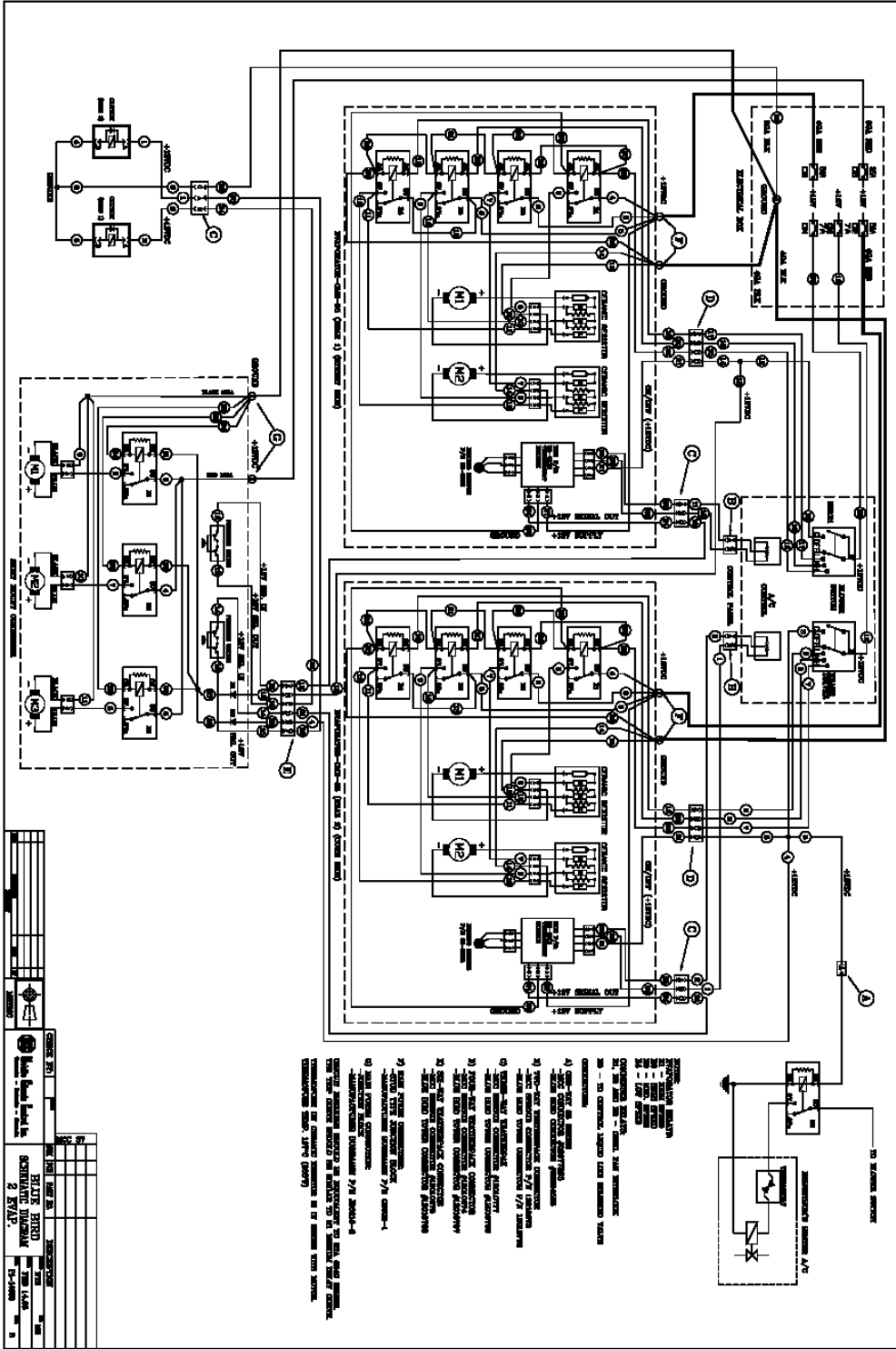



2v. WIRING SCHEMATIC (P1-14851) BBCV,A3RE ,A3FE – ECC-2TM21-SPLIT-SKIRT MOUNTED COND.

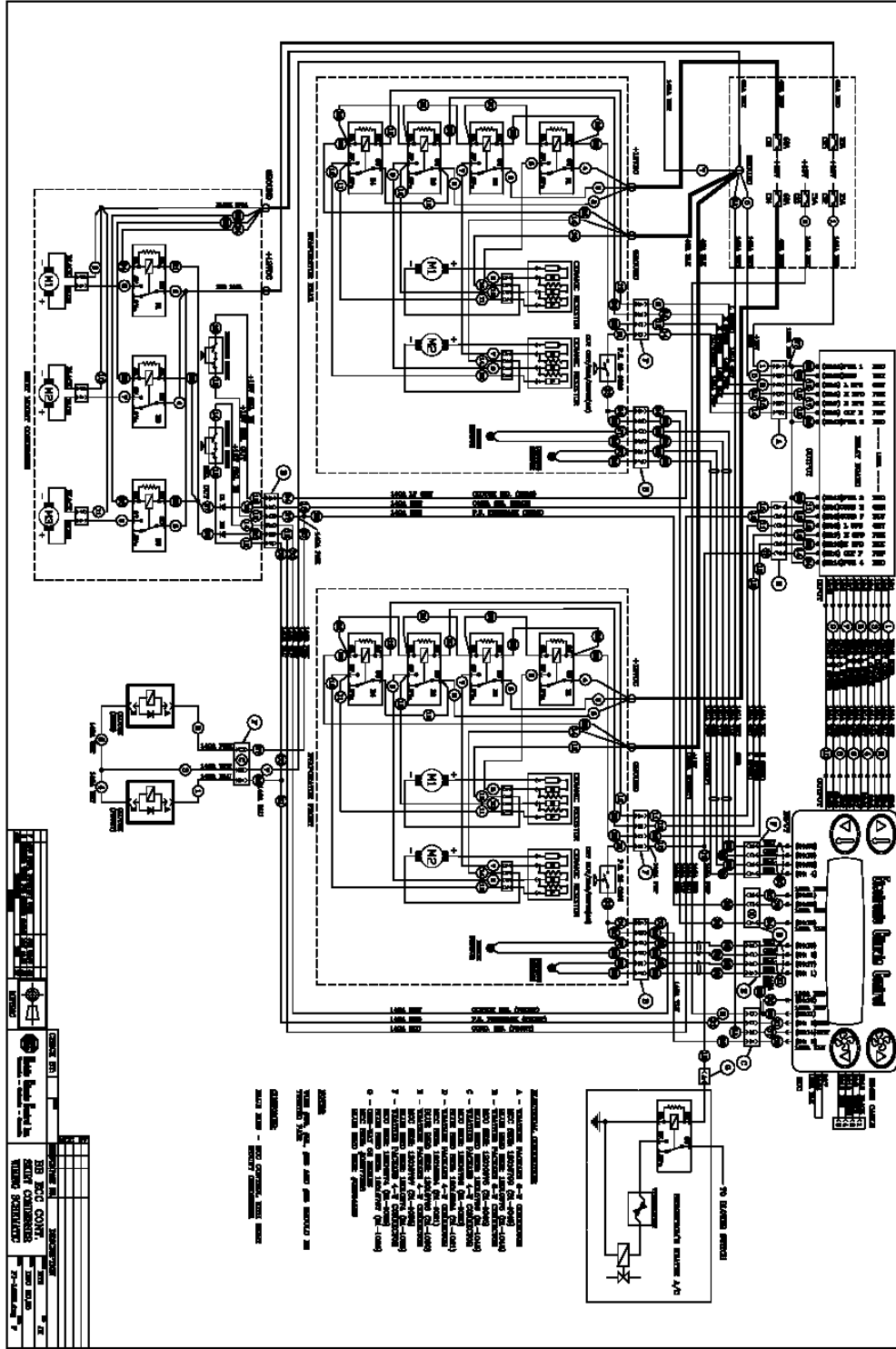



4d. WIRING SCHEMATIC- (P1-14854) SLIM LINE SYSTEM (06/07) – ECC - 2TM21-SPLIT-SKIRT MOUNT

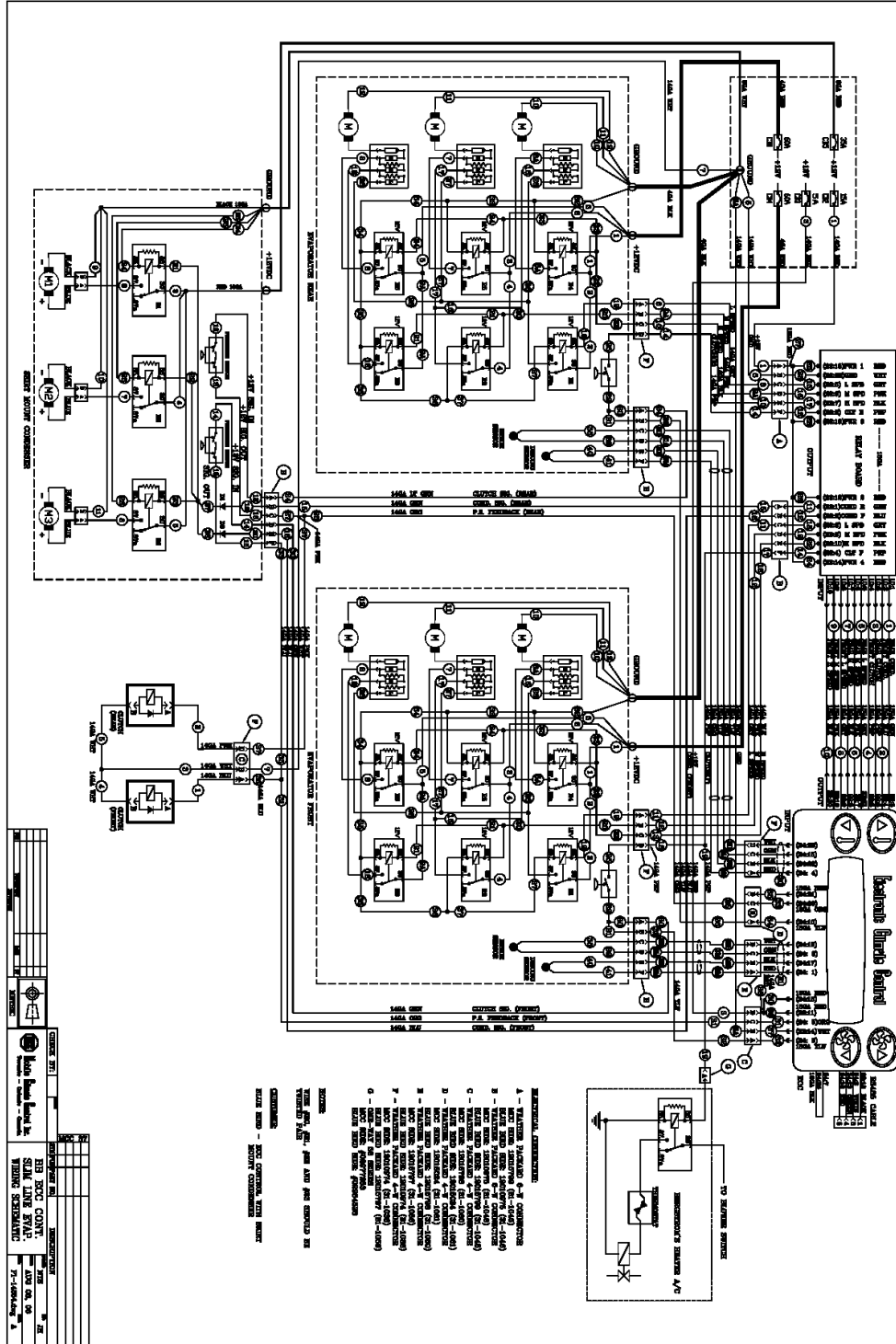



Electronic Climate Control User Guide

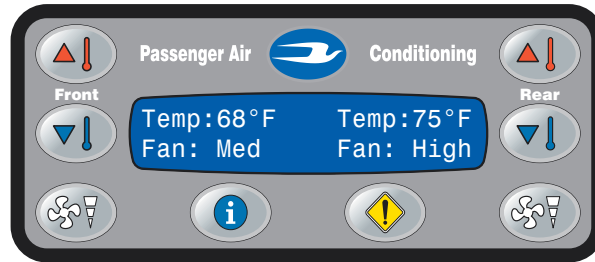

© 2006 Mobile Climate Control Industries Inc. Rev 0



Electronic Climate Control (ECC)

The ECC is a control interface, automatic climate controller, diagnostics and auto protection packed into one module. It allows precise temperature control, and yet is simple to use. With the built in diagnostic and auto protection mode, it greatly reduces warranty costs and downtime.



© 2006 Mobile Climate Control Industries Inc. Rev 0

ECC Controls

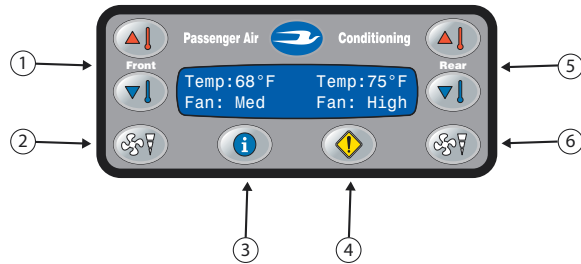

1 & 5. Front and Rear Temperature Set-Point Control

These Buttons changes air temperature setting for both front and rear air conditioning units. The controlled temperature range is between 16°C(62°F) and 28°C(82°F).

2 & 6. Front and Rear Fan Speed Control.

The front and rear fan speed can be set individually with the fan speed keys. Fan speeds can be cycled between low, medium and high then off.

3. Display Settings

This button allows access to display to changes. (Display contrast and brightness)

4. System Diagnostics

This button allows access to the ECC's system diagnostic mode.





ECC User Display

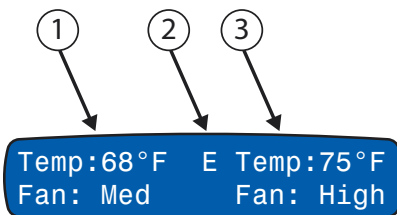

1 & 3. Temperature and Fan Speed Display

It displays set-point temperature in Celsius or Fahrenheit and fan speed in Low, Medium, High or Off for both front and rear air-condition units.

2. System Error Indicator

When the "E" flashes on the ECC's screen, it indicates there is a fault with the air condition system. Please enter diagnostic mode to locate the fault and correct as necessary.



© 2006 Mobile Climate Control Industries Inc. Rev 0

Basic Operation

Air Conditioning

1. Adjust set-point temperature to desired setting buy using temperature adjustment buttons.
2. Turn on fans and select speed by pressing fan speed button.

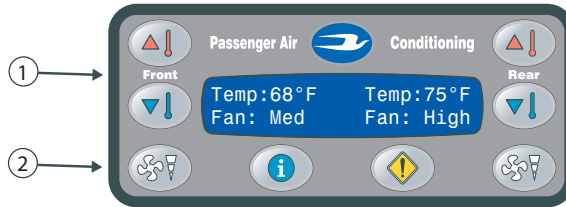

Display Settings

1. Press the Display Setting Button
2. Press Front Temperature Up or Down buttons to select between Brightness or Contrast.
3. Press Rear Temperature Up or Down to adjust settings.
4. Press the Display Setting Button again to return to main menu.

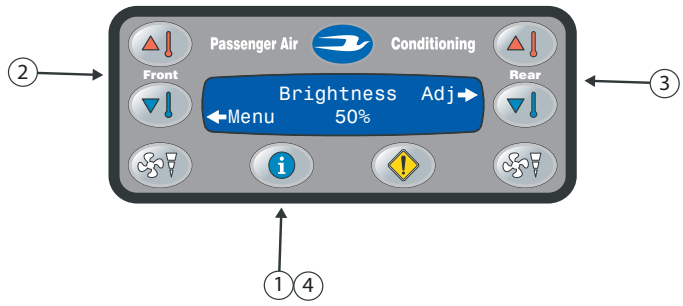



System Diagnostics

Diagnostics mode are divided into two sections:

Section 1: System run-time

Displays system run-time, system cycling times and supply voltage.

Unit run-time

Front and Rear unit run-time
 Front and Rear system cycle time
 Front and Rear evaporator run-time
 Front and Rear condenser run-time
 Main supply voltage

Section 2: System and sensor errors

Displays system faults and sensor errors.

Front and Rear return air temperature sensor status
 Front and Rear de-ice temperature sensor status
 Front and Rear low pressure switch
 Front and Rear High pressure switch
 Status of compressor or unloader (If applicable)

1. Press the Diagnostic Button to system diagnostic mode.
2. The user can scroll through by using Front or Rear Temperature Set-Point buttons.
3. Errors and run-time can be cleared by pressing the Rear Temperature Set-Point buttons.
4. Press the Diagnostic Button again to return to main menu.

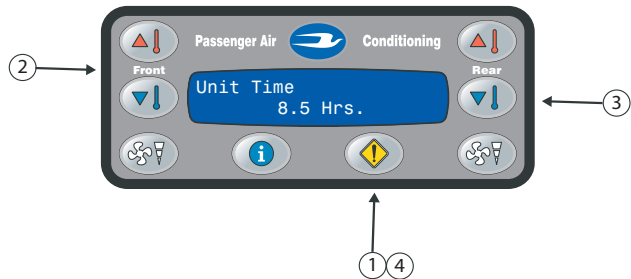

© 2006 Mobile Climate Control Industries Inc. Rev 0

Fr Evap Time 12.5 Hrs Rst→

System run-time:
Indicates run-time in hours that units has been running for evaporator, condensor and total system run-time.

Fr Return Temp. 75°F
Open: 0Shrt: 0 Rst→

Temperature sensor status:
Indicates real-time reading of return air and de-ice temperature sensors. This cannot be adjusted from controller. It also indicates malfunctions of sensor.

Fr Low Press. Sw. 0 Times Rst→

Pressure switch status:
Indicates the number of low or high pressure trips.

AC Working Full Capacity

Air conditioning system status:
Indicates that air conditioning system is working properly and whether unloader is energised.

Unloader Trips 4 Times Rst→

Unloader Status:
Displays the number time the compressor has unloaded on the system.

Voltage 13.8V

Indicates system voltage. If the system voltage drops below set by ECC, air conditioning units will shut down and ECC will indicated an error.





2s. SYSTEM SCHEMATIC-TRANSIT COMP.
(Dwg. P1-14849)
A3RE – ECC - BITZER – ROOF TOP CONDENSER

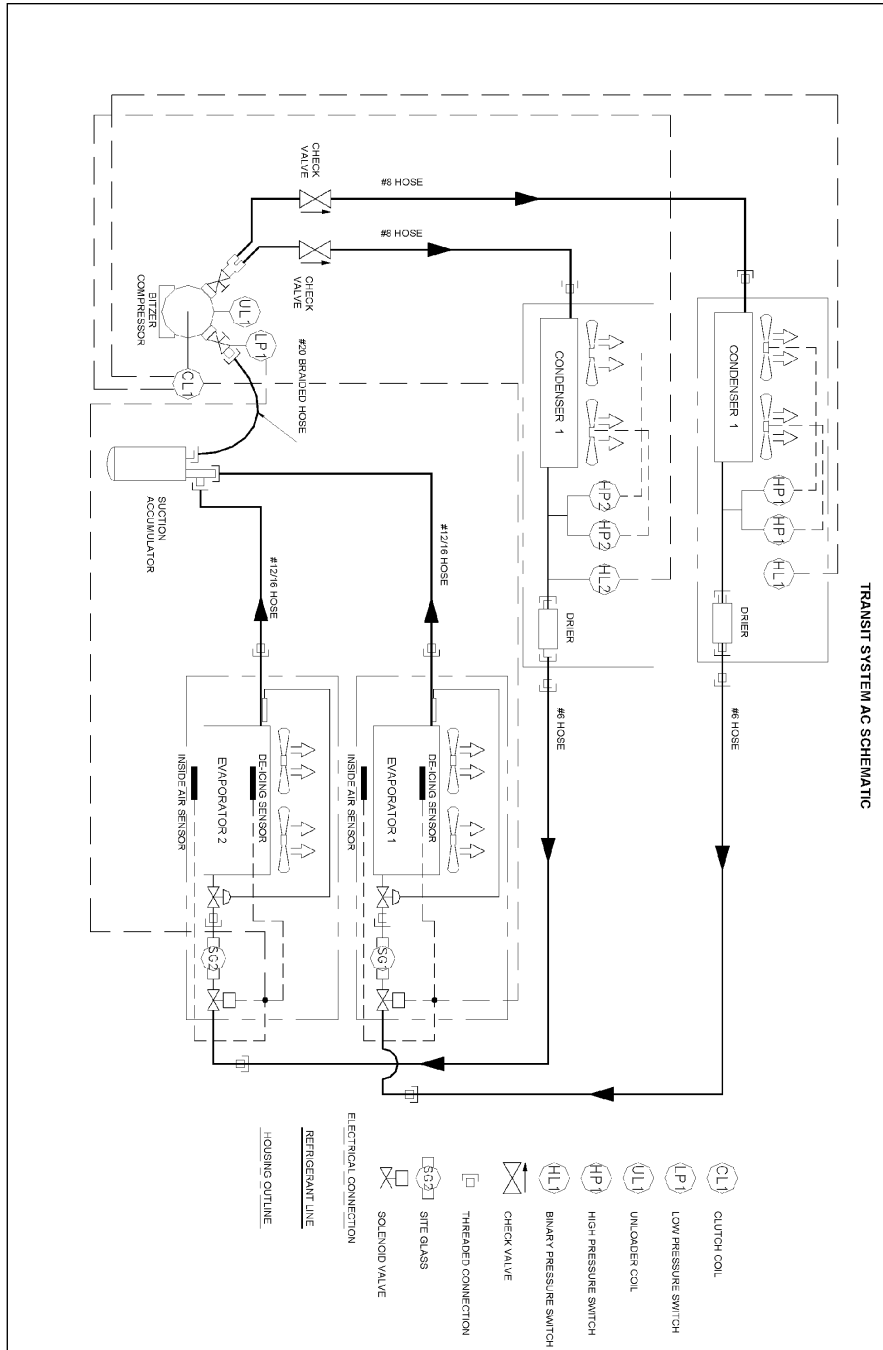

TRANSIT SYSTEM AC SCHEMATIC



Comfort Aire

AIR CONDITIONING SYSTEMS

WARRANTY MAINTENANCE CHECKLIST

Customer Name _____
Body Number _____
In-Service Date _____
Inspection Date _____
Odometer Reading _____
Dealer Name _____
Dealer Address _____
City | State | Zip _____ | _____ | _____
Technician Name _____
Technician Phone _____

Electrical Checks

- Check Compressor Clutch Operation
- Record Compressor Clutch Voltage
- Record Compressor Amperage
- Record Clutch Gap
- Check Condenser Fan Motor Operation
- Check All Three Blower Speeds
- Inspect Wire Harnesses
- Clean, Lubricate Condensor Power Studs
- Inspect Binary Pressure Switch Connectors

Refrigeration Checks

- Check Refrigerant Level
- Check Moisture Indicator
- Compressor Oil Acid Test
- Pressure Within Range
- Check Refrigeration Lines

Structural Checks

- No Loose or Broken Parts
- Clean Defrost Drains & Check Valves
- Inspect Compressor Mount Bracket
- Check Mount Bracket Torque
- Inspect Belts & Adjust Tension
- Inspect, Clean and/or Replace Evaporator Side Filters
- Vacuum Evaporator Coils
- Wash Condensor Coils
- Check All Mounting Bolts

*For GENUINE BLUE BIRD replacements parts, contact your
Blue Bird Authorized Dealer*



BLUE BIRD

T E C H N I C A L C O M M U N I C A T I O N S