

MULTIPLEX SYSTEM

Overview

Many of the Blue Bird Vision's electrical circuits communicate and interact with each other through an advanced Multiplex control system. This solid-state system provides significant advantages over traditional wiring:

- Multiplex simplifies the system by replacing multiple mechanical relays and switches with reliable solid-state components.
- Multiplex provides intelligent programmed (rather than mechanical) interaction between components. Multiple component signals are transmitted simultaneously along a common data bus, and are monitored and controlled by a digital microprocessor.
- The Multiplex module also serves as a centralized troubleshooting tool which simplifies the process of isolating causes of electrical malfunctions, without requiring special diagnostic hardware/software interfaces.

The Multiplex system may be thought of as similar in purpose and function to already-familiar electronic control devices such as the engine ECU, or the Weldon warning light control module. The main differences are that the programmable module(s) of a multiplex system are programmed for specific vehicles, and provides information to the technician by means of a series of visible LED indicators rather than by means of special diagnostic interface ports.

The Multiplex systems installed on the Blue Bird Vision is relatively simple. It primarily controls chassis-related on/off state devices. Most body circuits are wired conventionally. (Some chassis circuits receive Inputs from body components such as vandal locks and door signal switches and some body circuits are controlled by outputs from the MPX system such as turn signals.) Although the modular nature of Multiplex components allows it to be configured for complex systems using multiple modules located in several control "zones", the Vision's Multiplex system consists of one zone with a single control module.

The central component of the Multiplex system is the MPX Module, the microprocessor which handles communication between various circuits. The role of the MPX Module is similar to that of a telephone switchboard which makes and breaks connections for multiple individual "calls" (between two components) and/or "conference calls" (between several components), simultaneously. Input signals from various circuits arrive at the MPX Module. Inside the Module, the Inputs trigger Output signals which activate/deactivate other components or circuits. The programming of the MPX Module determines which Input (or combination of Inputs) results in any particular Output. Specific programming of each module is identified by a program control number on the front of the module. The Module also internally generates a Feedback signal for each load circuit, and continually monitors the Feedback signals to verify the integrity of the circuits, much as a technician would use an Ohm meter to test continuity.

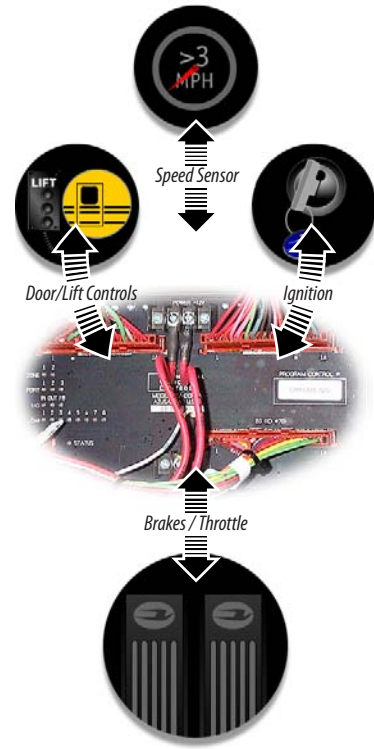

Multiplex System

The Brake & Throttle Interlock system is an example of how multiplexing handles simultaneous communications between seemingly unrelated components.

An array of Light Emitting Diodes (LEDs) on the MPX Module provides the means by which a technician can visually monitor the status of individual Inputs, Outputs, and Feedbacks. The technician uses a dash-mounted Diagnostic Switch to select which circuits the LEDs display, and whether they indicate Inputs, Outputs, or Feedback. To interpret the LEDs, the technician refers primarily to two printed references presented later in this chapter: the Input/Output charts and the Ladder Logic diagrams.

As with any new technology, troubleshooting and servicing a Multiplex system requires an initial familiarization, a firm conceptual understanding, and the acquisition of new skills (such as reading Ladder Logic diagrams). However, Multiplexing does not supersede or invalidate what a qualified electrical technician already knows about troubleshooting and diagnosis. Rather, it provides a new and valuable tool to assist the qualified technician in narrowing down the source of a problem, thereby minimizing downtime and reducing operating costs.

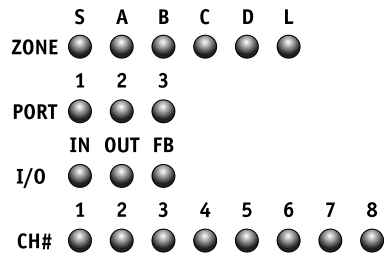



MPX Module

The CV-CCM-C Main Bus Controller (MPX Module) is mounted in the Power Distribution Unit to the right of the driver's area. The Module electronics are powered by "clean" 12 volt power from the battery bus bar, which isolates it from the normal current fluctuation or "line noise" of power circuits affected by the alternator. Five connectors on the module labeled A, B, C, D, and E, receive Inputs from sensors and switches, and convey Outputs to actuators, lamp loads, and other devices.

Four rows of LEDs indicate the status of the controlled circuits:

Zone: The top row consists of six LEDs, labeled S, A, B, C, D, and L. The Blue Bird Vision's single-zone Multiplex System is contained within Zone A. (Note that all of the addresses shown in the Input and Output charts begin with "A") The Zone L LED goes off when the Multiplex System enters Sleep Mode. S and A are the only functionally active LEDs, B, C, D, and L are not active at this time. When power is first applied to the system, all the LEDs come on momentarily, and then go off. The Zone A LED then blinks a number of times, corresponding to the revision version of the software installed. Finally, the Zone A LED goes off and the system is in its normal operating mode.

Port: The three LEDs in this row correspond to the three input/output connector Ports. When the MPX Module has been put in diagnostic mode by pressing the Diagnostic Switch, these LEDs indicate which Port the rows of I/O and CH# LEDs are presently indicating.

I/O: When in diagnostic mode, the three LEDs in this row, labeled IN, OUT, and FB, indicate whether the row of CH# LEDs immediately below are presently monitoring Inputs, Outputs, or Feedback.

CH#: When in diagnostic mode, the bottom row of eight LEDs indicate the current state (active on or inactive of) of each of the Inputs, Outputs, or Feedback being monitored (depending upon which I/O LED is on) of the Port presently indicated by the Port LEDs.

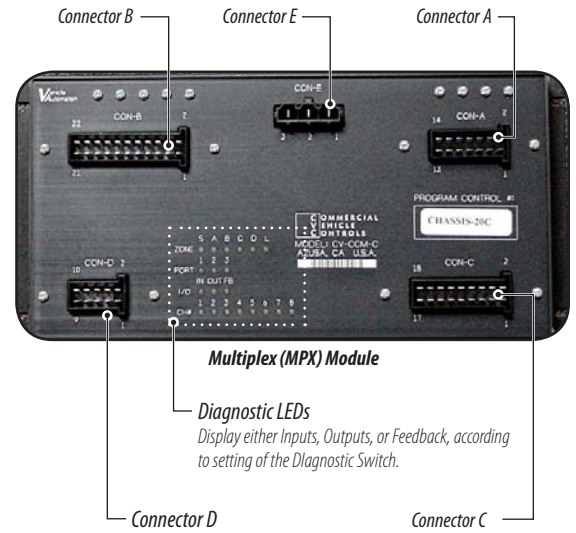

Multiplex (MPX) Module

Diagnostic LEDs

Display either Inputs, Outputs, or Feedback, according to setting of the Diagnostic Switch.

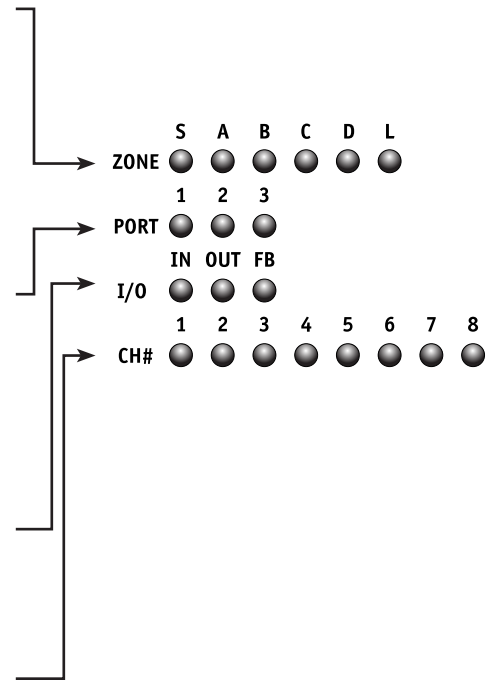

The LEDs serve as visual indicators. However, they also represent the type of mechanism by which Output circuits are "notified" of the presence of particular Inputs. Inside the MPX Module, an LED in a given Input circuit turns on when the circuit is Active. Nearby, a solid state photo sensor in the Output circuit detects the internal light source and either closes or opens an Output Circuit according to the programming of the Module. In turn, the status of the Output Circuit is similarly sensed by a photo sensor in the load circuit. In this sense, the LEDs can be thought of as actually performing the function of electrical relays.

Rather than having fuses, the MBC provides solid state circuit protection. If an Output is turned on and is drawing too much current (as in the case of a short circuit), the Module turns the Output off before there can be any damage to the Output transistor and circuit.

LEDs As Circuit Relays...

The CPU "watches" Input LEDs with photosensors... and activates the appropriate Output(s).

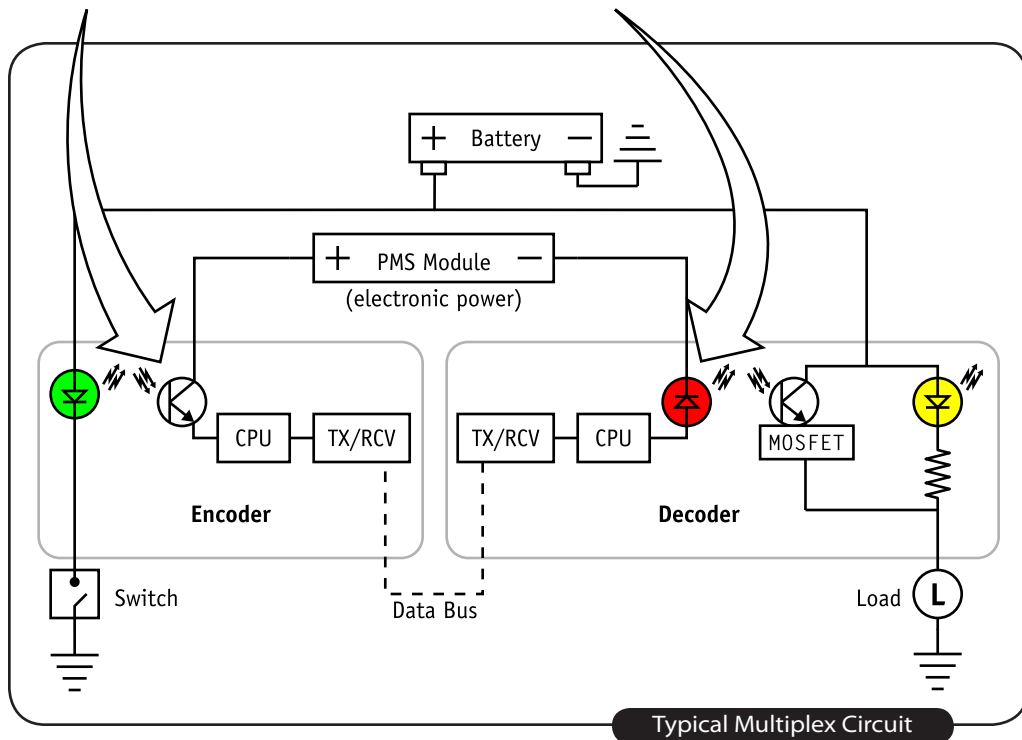

Typical Multiplex Circuit

Feedback Circuits

Internal Feedback circuits in the MPX Module are connected in parallel to the load side of Output circuits. A Feedback circuit conducts a faint current through the load, a resistor, and the Feedback LED. Thus, when the module is set to display Feedbacks, each of the bottom row LEDs acts much like a conventional ohm meter, indicating the integrity (continuity) of the load side of the circuit it monitors.

When the load circuit is switched on, full working current is able to bypass the Feedback LED circuit. This removes the voltage differential across the LED and resistor, and the LED goes off.

Thus, in a properly performing load circuit, the Feedback LED should be on (indicating that the circuit is ready) when the circuit is Inactive; and should be off when the circuit is Active. If the Feedback LED is on while the circuit is Active, this is an indication of a short in the load side of the circuit.

LEDs As Circuit Testers
 A signal current passing through the load lights the Feedback LED whenever the circuit is Inactive off.

When the Output becomes active on, a photosensor detects it, and closes the load circuit, providing a path for current to bypass the Feedback LED and its resistor. The Feedback LED goes off.

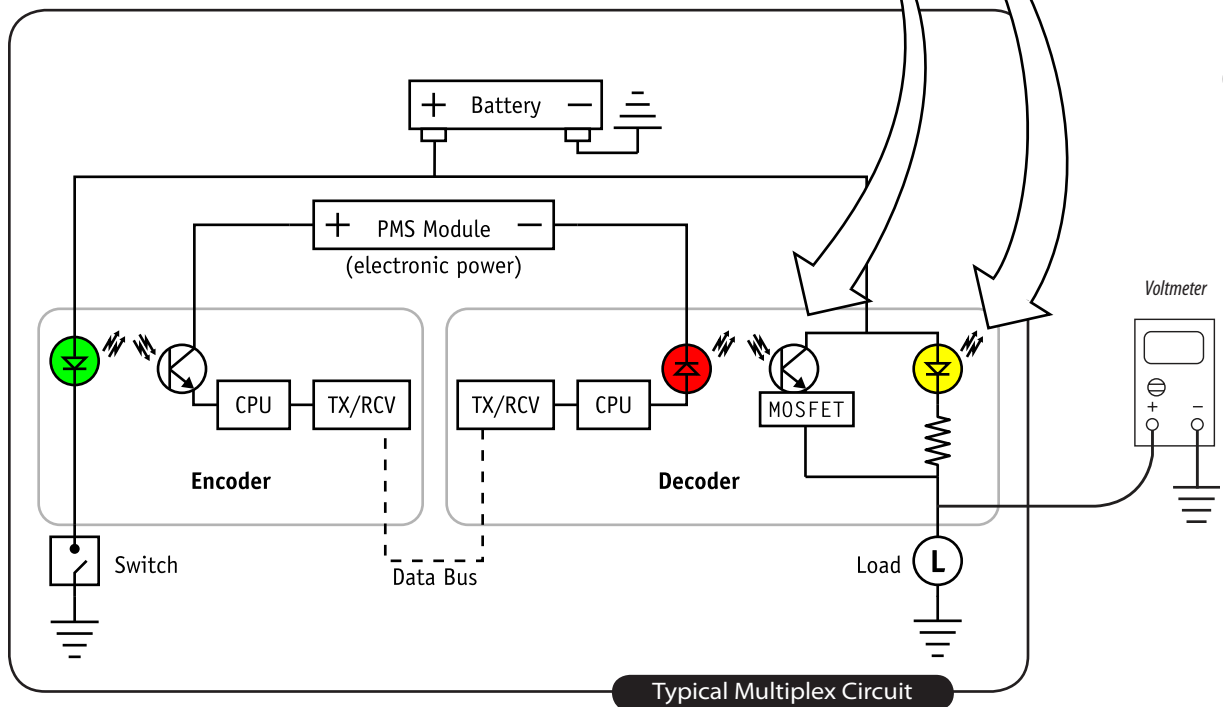

Sleep Mode

The normal monitoring functions of the MPX Module draw a small current from the vehicle batteries. To minimize battery drain while the bus is parked, the Multiplex system automatically goes into a low current-draw Sleep Mode one hour after ignition is turned off. The Module awakens from Sleep Mode when either the ignition switch is turned on or one of a number of other circuits is used (headlights, stoplights, directional lights, horn, accessory switch). There is a slight delay while the system is awakening from Sleep Mode when the system is turned on.

The Sleep Mode delay may differ on some units, in accordance with specific state requirements. For example, in a state which requires the lift to be operable only with the ignition switch removed, a longer delay time may be programmed to allow time for the lift to be used.

Diagnostic Mode

Except for the Zone S LED (which indicates Sleep Mode), the other LEDs only light when the MPX Module has been put into Diagnostic mode by pressing the Diagnostic switch. Each subsequent press of the switch cycles through the Ports and I/O options in the following order:

- 1st press: Puts the Module in Diagnostic Mode, displaying Port 1 Inputs.
- 2nd press: Port 1 Outputs.
- 3rd press: Port 1 Feedbacks.
- 4th press: Port 2 Inputs.
- 5th press: Port 2 Outputs.
- 6th press: Port 2 Feedbacks.
- 7th press: Port 3 Inputs.
- 8th press: Port 3 Outputs.
- 9th press: Port 3 Feedbacks.
- 10th press: Ends Diagnostic Mode. Only the Zone 2 LED remains on.

	S	A	B	C	D	L	
ZONE	●	●	●	●	●	●	
	1	2	3				
PORT	●	●	●				
	IN	OUT	FB				
I/O	●	●	●				
	1	2	3	4	5	6	7
CH#	●	●	●	●	●	●	●

In this example, the LEDs are indicating the A2 Feedbacks...

	S	A	B	C	D	L	
ZONE	●	●	●	●	●	●	
	1	2	3				
PORT	●	●	●				
	IN	OUT	FB				
I/O	●	●	●				
	1	2	3	4	5	6	7
CH#	●	●	●	●	●	●	●

...and here, the A2 Outputs.

- LED on
- LED off



ABS Diagnostic Switch



Diagnostic Mode Switch
Cycles the MBC's display through Ports, Inputs, Outputs, and Feedbacks. (3-position momentary)



Multiplex References

Two printed references are provided to assist the technician in interpreting the Main Bus Controller's LEDs:

Input and Output Tables

Generally speaking, the first step in troubleshooting an electrical problem is to determine whether the affected or suspected circuit is part of the Multiplex system. The Input and Output Tables included in this chapter list the circuits with which the Multiplex system interacts.

Multiplex Inputs Table. The Inputs Table lists the circuits from which the Main Bus Controller receives Input signals.

The second column (Zone/Port-Input#) shows the Multiplex "logical address" and/or "LED address" of each Input circuit. These addresses are not circuit/pin locations, but relate directly to the Ladder Logic diagrams. For example, the Accessory Switch address is A2-I03 (Zone A, Port 2-Input number 03).

The third column (connector port) shows the physical pin location of the circuits; which Pin of which Port Connector on the MPX Module to which the Input circuits are wired. For example, the Input wire leading from the Accessory Switch is connected to the Module at AC-03 (Port C, Pin 03).

The third and fourth columns list the wire color and whether the Input is a ground or a 12 volt connection.

Outputs Table. The Outputs table lists the circuits for which the Main Bus Controller issues Outputs. This table is organized similarly to the Inputs table:

The second column (Zone/Port-Output#) shows the Multiplex "address" and/or "LED address" of each Output circuit. These addresses are not circuit/pin locations, but relate directly to the Ladder Logic diagrams. For example, the Accessory Hot Output's address is A3-O08 (Zone A, Port 3-Output number 08).

The third column (connector port) shows the physical pin location of the circuits; which Pin of which Port Connector on the MPX Module to which the Output circuits are wired. For example, the Accessory Hot Output signal wire is connected to the Module at AB-116 (Port B, Pin 116).

The third and fourth columns list the wire color and whether the Output is a ground or a 12 volt connection.

The Outputs Table has a sixth column labeled Ladder Chart Line. This is the line of the Ladder Logic which describes the requirements for the specific Output. For example, to troubleshoot the Accessory Hot Output, you would refer to the Ladder Logic line 34, which describes the requirements for an Accessory Hot Output. (Note that the Zone/Port-Output# address of the Accessory Hot Output is the item at the right end of the Logic Line 34.)

Multiplex "Logical Address"
and/or LED Address

Zone	Port	Type	Number
A	2	I	03

A2-I03

Physical Connector
Pin Location

Zone	Connector port	Ground if 0 12v if 1	Pin Number
A	C	0	03

AC-003

Ladder Logic Diagrams

The Ladder Logic Charts are not wiring schematics. They are diagrams of the “logic,” or rules which the Multiplex program follows to determine which set of Inputs and/ or other conditions results in each particular Output. Each horizontal “rung” of the diagrams graphically describes a set of requirements for the Output indicated at the right end of the line. Most of the requirements are either Inputs or other Outputs. (There are occasional requirements for signals which are generated internally by the MPX Module’s internal circuitry or programming, rather than by a physical component on the bus.)

Each symbol on a logic line represents one particular requirement for the Output indicated at the right end of the line. Reading a line from left to right, *all* of the requirements encountered along the path must be satisfied in order for the Output at the right end of the line to occur. Thus, the horizontal lines between requirement symbols may be thought of as logical “and” statements. (An important basic principle of Ladder Logic is that a symbol can denote a requirement for either the presence or *absence* of a condition or signal.)

Some Logic diagrams provide alternate paths by which to reach the Output at the right end. These alternate paths may be thought of as logical “or” statements. If a requirement on the uppermost path is not met, the Output may still be achieved if all of the requirements of an alternate path are met.

Thus, troubleshooting a circuit which interacts with the Multiplex system involves finding the Ladder Logic diagram for the desired Output; and then systematically verifying each of its requirements by comparing the chart to what is actually happening according to the LEDs on the MPX Module. When a discrepancy is found, it is an indication that the problem exists “upstream” from that point in the Logic. This will become clearer as you continue through this chapter.

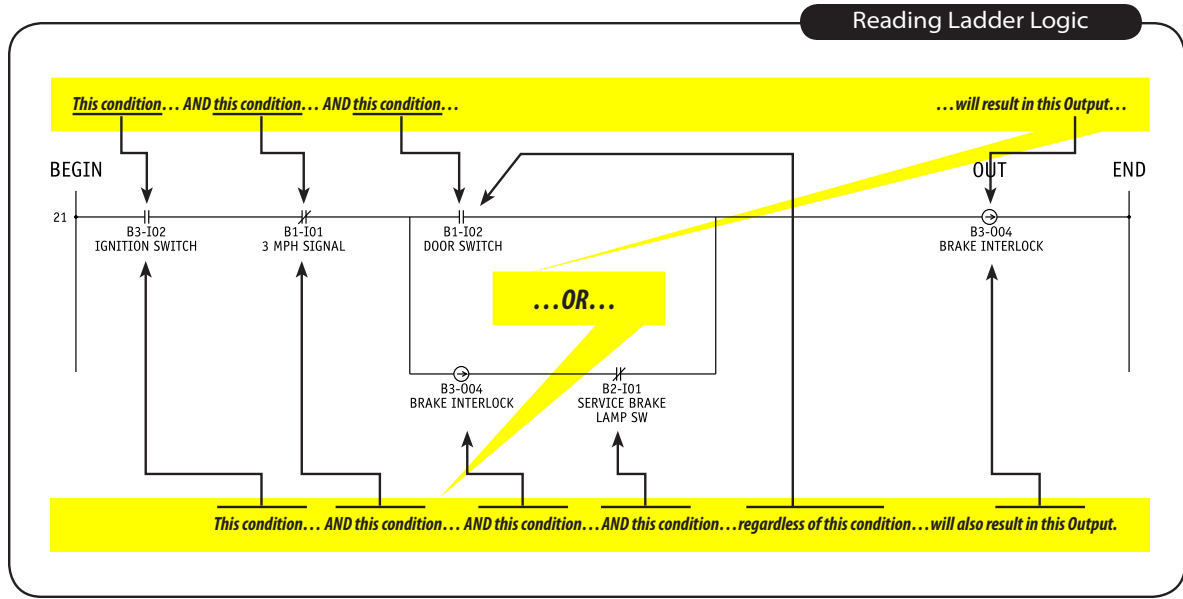

Ladder Logic Symbols

Following is a description of the symbols which appear on the Ladder Logic charts:

Inputs. A Logic Ladder diagram may require a particular Input to be either Active or Inactive. Active Inputs are symbolized by two vertical lines. Inactive Inputs are indicated by the same symbol, but with a diagonal slash.

Outputs. Outputs do not only occur at the right end of Logic diagrams. A particular Output (or its absence) can also be a requirement for another Output. There is only one true functional output per logic line located on the far right. All other outputs are required conditions. Therefore, symbols exist for both Active and Inactive Outputs. An Active Output is symbolized by a right-pointing arrow inside a circle. The same symbol with a diagonal slash indicates an Inactive Output.

Timers. A Timer is an internal signal generated by the Multiplex program. Timers are represented as rectangles containing abbreviated labels, such as the Turn Signal Flasher at address B1-I01, labeled FLS.

Flags. A Flag symbol is identical to an Output symbol (right-pointing arrow inside a circle), but with a letter F next to it. A Flag may be thought of as similar to a function in programming; a "shorthand" way to refer to another "mini-program", or set of commands. Thus, a Flag is a kind of Output, and has its own Ladder Logic diagram. Each flag has its own logic line but does not have an output pin, connector and circuit associated with it. When a Flag is encountered somewhere along a Logic Line, its own Logic diagram must be examined in turn to fully investigate the circuit.



Active Input LED On



Inactive Input LED Off

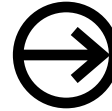

Active Output On



Inactive Output Off



Active Timer (Flasher Shown)

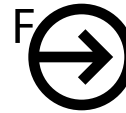

Active Flag On



Inactive Flag Off

Logical “Latch Relays”

Occasionally, a particular Output may appear to be a requirement for itself. In such situations, it is helpful to realize that the Multiplex program performs the horizontal “rungs” of a Ladder in sequence, not all at once. If an initial set of conditions has made an Output true, that Output may then become one of a second set of conditions which will *keep* the Output true—even if one or all of the initial conditions changes. The Brake Interlock circuit is an example of this kind of Logic Line.

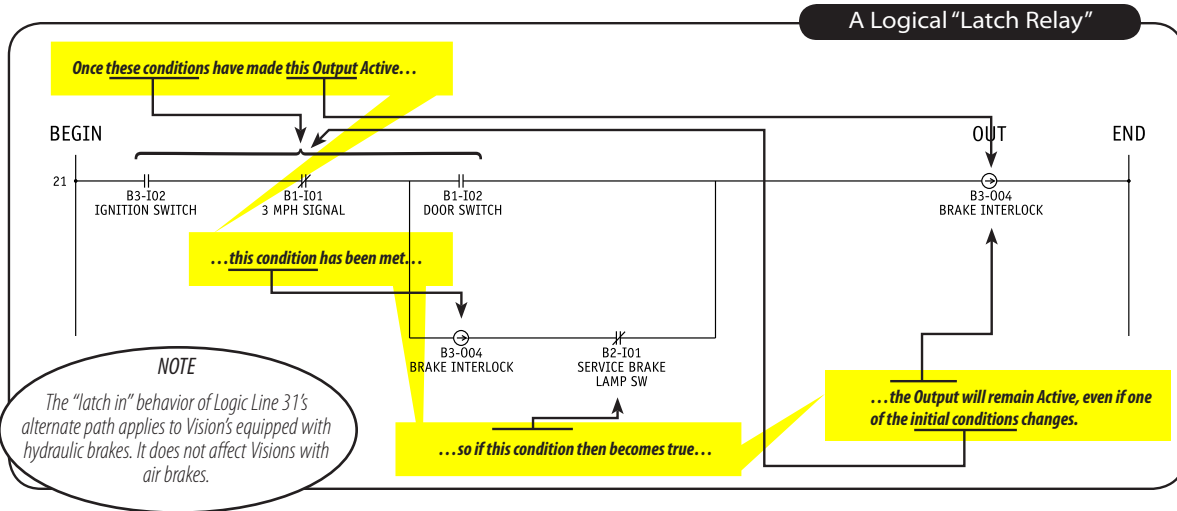



Vision MPX Simulator

Blue Bird has provided another reference tool to help technicians become more quickly acquainted with the Vision's Multiplex system. On the CD included with this manual is a file named **VisionMPXSimulator.exe**. This is a small self-running Macro-media® Flash®-based application, suitable for use on most current Windows® computers.

CAUTION *The Vision Multiplex Simulator is provided as a reference tool to help service technicians become more quickly familiar with the Blue Bird Vision's Multiplex system. It is intended for training/learning purposes only (not for actual troubleshooting). The software is only a SIMULATION of the Blue Bird Vision's Multiplex system. Although it imitates the behavior of the Vision's Multiplex Module, it does not contain the actual multiplex program. Because the actual program installed on buses is subject to change at the factory, the behavior of the Vision MPX Simulator may not exactly match that of your particular Vision unit(s).*

The Vision MPX Simulator operates upon a script which imitates the logic of the Ladder Logic diagrams of a 2007 Vision. Interactive on-screen controls represent the driver controls which generate Multiplex Inputs. Other animated graphic elements indicate the results of most Multiplex Outputs, as they are generated in response to the Inputs. An on-screen Diagnostic Switch allows the user to cycle the bank of "LEDs" to display Inputs, Outputs, or Feedbacks, simulating the behavior of the actual MPX Module. For reference while observing the behaviors of the LEDs, at the top of the screen is a scrolling list of the same set of Ladder Logic charts printed in this manual.

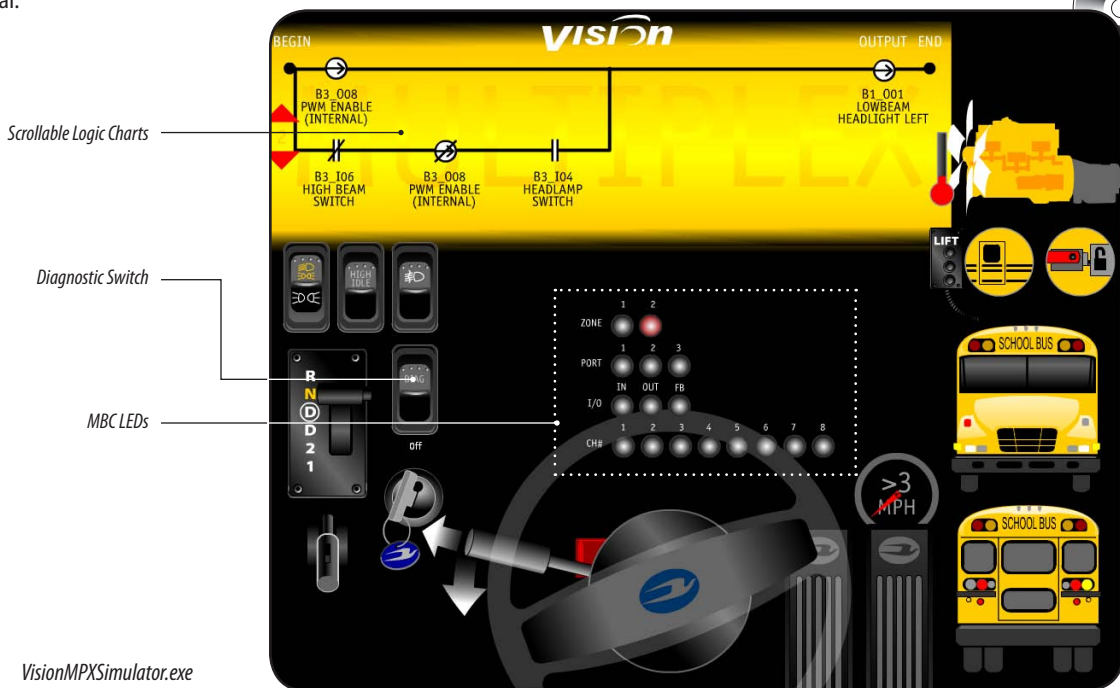

VisionMPXSimulator.exe

Input Tables

Multiplex Inputs Table

	Circuit Description	Input LED	Connector / Port-Pin	Wire Color	Input
1	Accessory Switch	A2-I03	AC-003	YL	Ground
2	Brake Light Switch	A1-I05	AB-111	RD	12 Volts
3	Diagnostic Switch	A3-I07	AC-015	GN	Ground
4	Door Signal	A3-I03	AC-011	BL	Ground
5	Fan, Cooling Disable (Cat only)	A1-I08	AA-108	OR	12 Volts
6	Headlight Switch	A2-I06	AC-006	OR	Ground
7	High Beam Switch	A2-I07	AC-007	OR	Ground
8	High/Fast Idle	A2-I01	AC-001	GN	Ground
9	Horn Signal	A3-I02	AC-010	GY	Ground
10	Ignition Switch	A2-I04	AC-004	PK	Ground
11	Interlock Feedback	A3-I05	AC-013	OR	Ground
12	Neutral Signal	A1-I03	AB-107	RD	12 Volts
13	Park/Tail Light Switch	A1-I07	AA-004	BN	Ground
14	Park Brake Switch	A1-I06	AB-012	PK	Ground
15	Reverse Signal	A1-I02	AB-004	BL	Ground
16	Speed Signal	A1-I01	AB-003	RD	Ground
17	Starter Lockout Signal	A2-I02	AC-102	RD	12 Volts
18	Starter Switch	A2-I05	AC-005	PU	Ground
19	Turn Signal, Left	A2-I08	AC-008	YL	Ground
20	Turn Signal, Right	A3-I01	AC-009	GN	Ground
21	Vandal Lock	A3-I08	AC-016	TN	Ground
22	Washer Pump Switch	A1-I04	AB-108	PK	12 Volts
23	Intermittent Wiper Switch	A3-I04	AC-112	BK	12 Volts
24	SCC Alarm	A3-I06	AC-014	GN	Ground

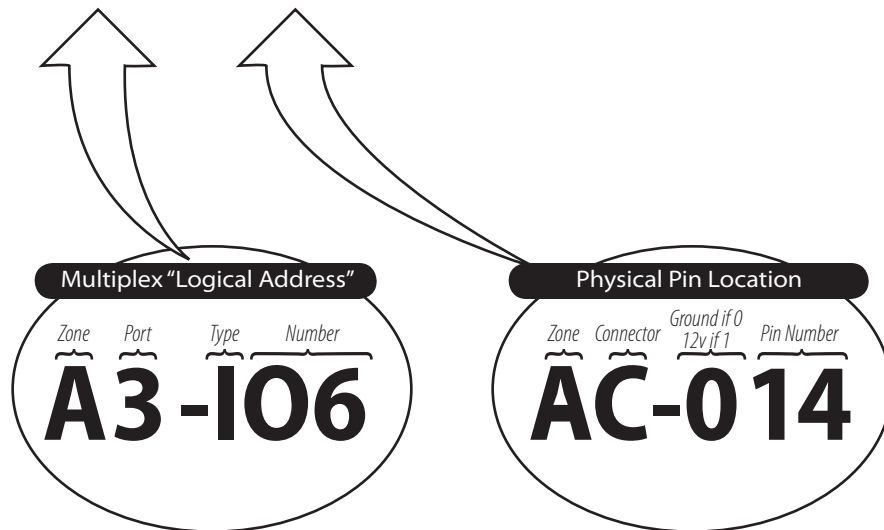



Output Tables

Multiplex Outputs Table

	Circuit Description	Output LED	Connector / Port-Pin	Wire Color	Output	Ladder Chart Line
1	Accessory Hot	A3-008	AB-116	GN	12 Volts	34
2	Back up Lights	A2-004	AA-107	BL	12 Volts	16
3	Brake Interlock	A3-005	AB-015	WH	Ground	31
4	Fan Control Power <small>(Cat Only)</small>	A2-002	AA-103	OR	12 Volts	14
5	High/Fast Idle	A3-001	AB-001	OR	Ground	27
6	Headlight, High Left	A1-003	AA-110	RD	12 Volts	7
7	Headlight, High Right	A1-004	AA-112	PU	12 Volts	8
8	Headlight, Low Left	A1-001	AA-102	BN	12 Volts	5
9	Headlight, Low Right	A1-002	AA-106	OR	12 Volts	6
10	Horn	A1-008	AB-114X	BK	12 Volts	12
11	Ignition	A2-006	AA-111	OR	12 Volts	18
12	Ignition Dropout	A2-007	AA-113	PK	12 Volts	19
13	Park Brake	A2-003	AA-105	PK	12 Volts	15
14	Park Lights	A1-006	AB-106	BN	12 Volts	10
15	Shift Inhibit Signal	A3-002	AB-005	GN	Ground	28
16	Lift Enable	A3-006	AB-021	RD	Ground	32
17	Ex. Brake Stop Light <small>(Cat only)</small>	A3-004	AA-09	RD	12 Volts	30
18	Starter Relay	A2-008	AA-114	RD	12 Volts	20
19	Stop Lights Relay	A2-005	AA-109	RD	12 Volts	17
20	Throttle Interlock	A3-003	AB-009	BN	Ground	29
21	Turn Signal, Left	A1-005	AB-102X	YL	12 Volts	9
22	Turn Signal, Right	A1-007	AB-110X	GN	12 Volts	11
23	Wiper Washer Pump	A3-007	AB-122	TN	12 Volts	33
24	Intermittent Wiper Motor	A2-001	AA-101	BN	12 Volts	13
25	Shutters	A2-002	AA-103	OR	12 Volts	14

LADDER LOGIC DIAGRAMS

Caterpillar C702 & Cummins ISB02

2002 Emission Standard Engines

Symbols Key

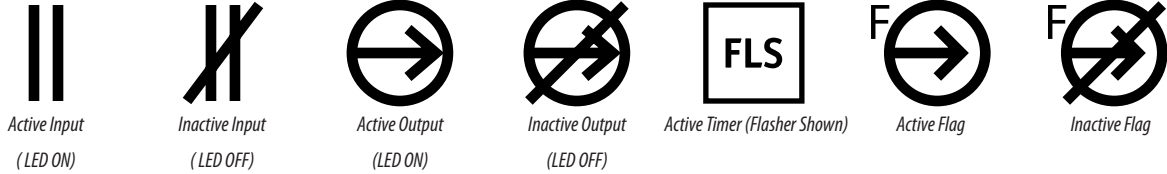

PORT 1 FLAGS

Caterpillar C7 & Cummins ISB

2002 Emission Standard Engines

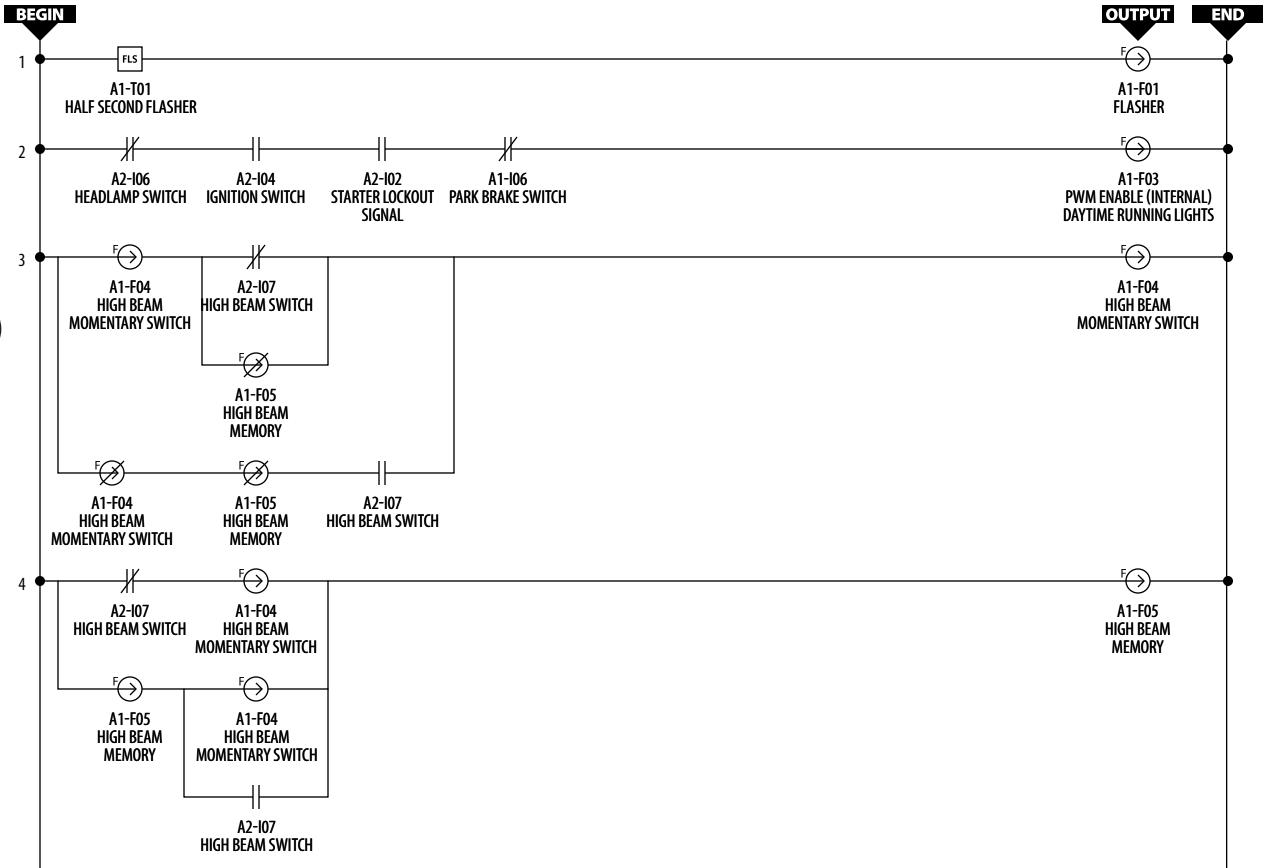



PORT 1 OUTPUTS

Caterpillar C7 & Cummins ISB
2002 Emission Standard Engines

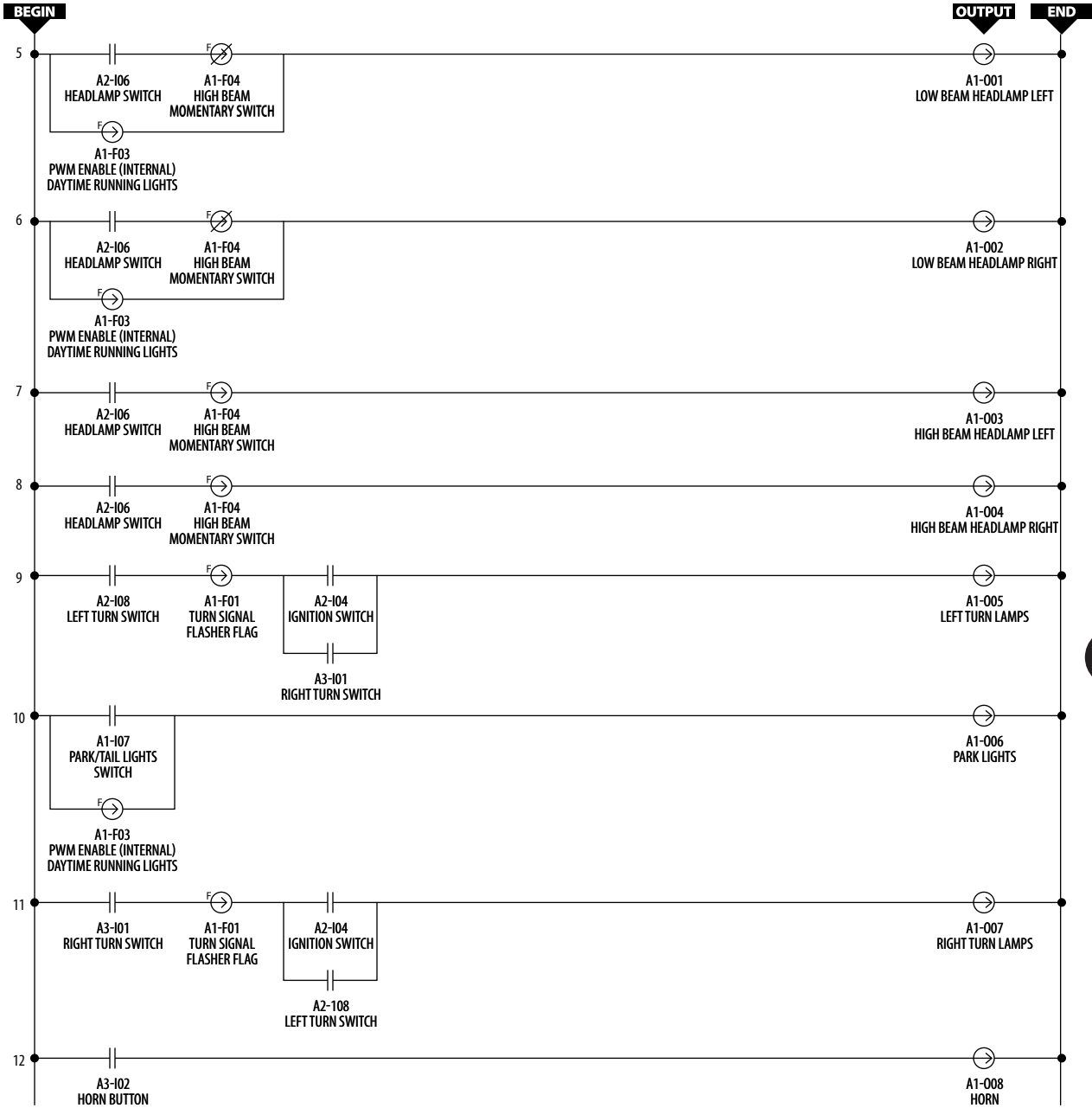

Symbols Key

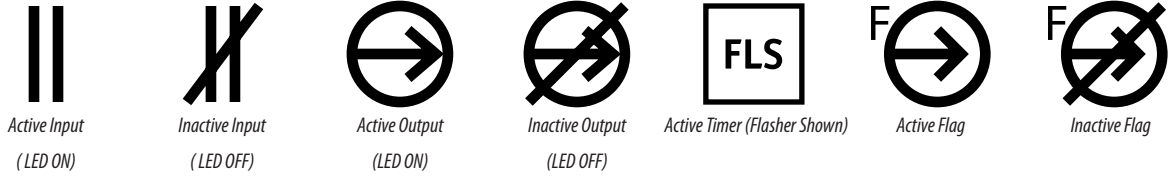

PORT 2 OUTPUTS

Caterpillar C7 & Cummins ISB
2002 Emission Standard Engines

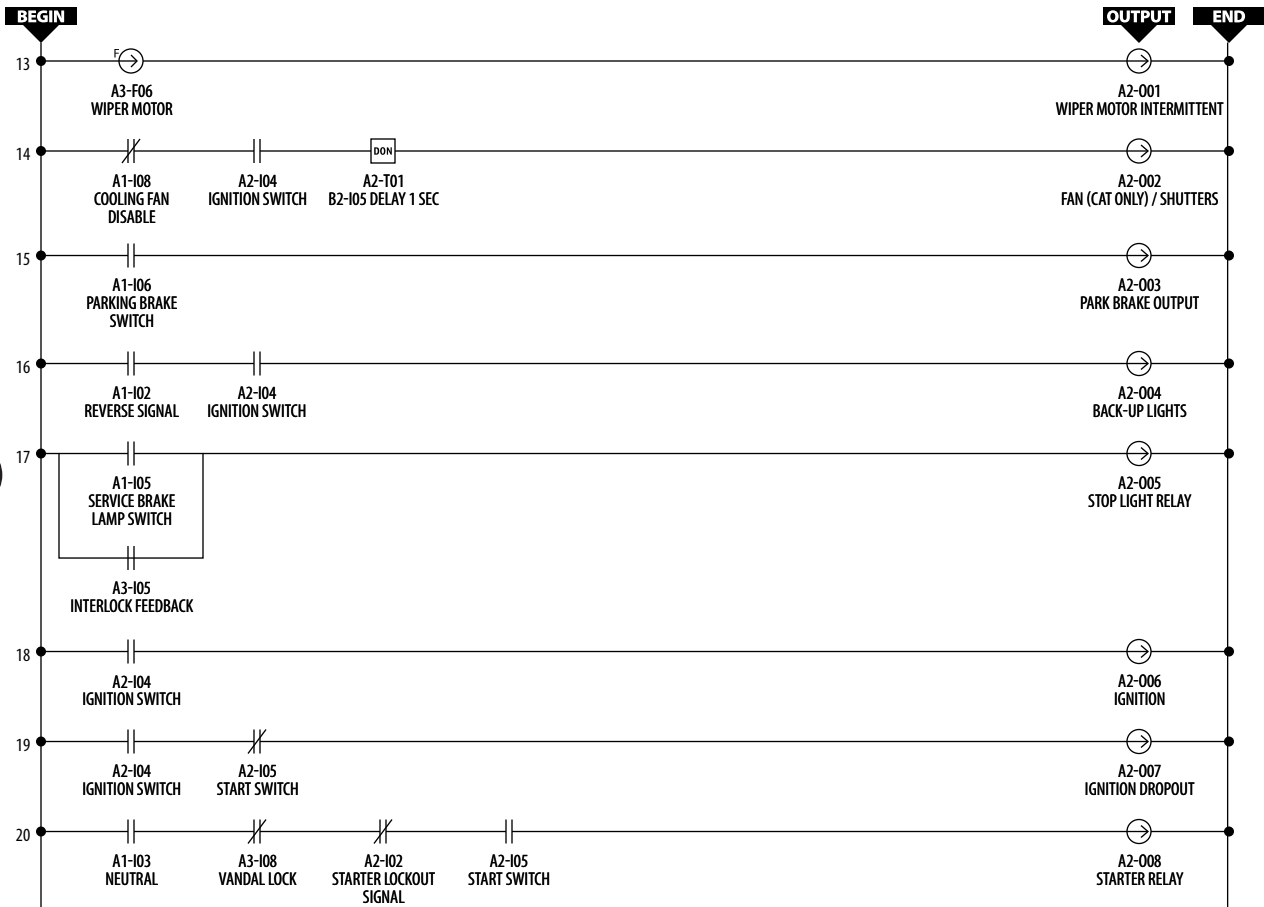



Symbols Key

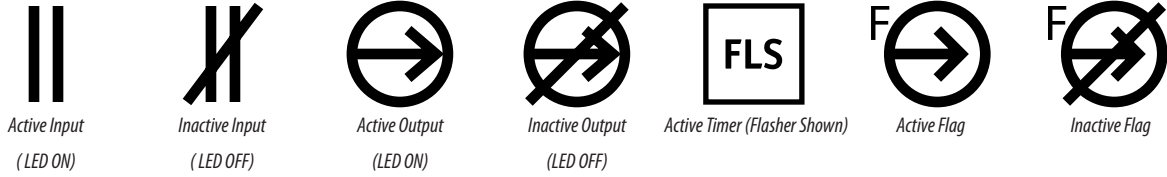

PORT 3 FLAGS

Caterpillar C7 & Cummins ISB
2002 Emission Standard Engines

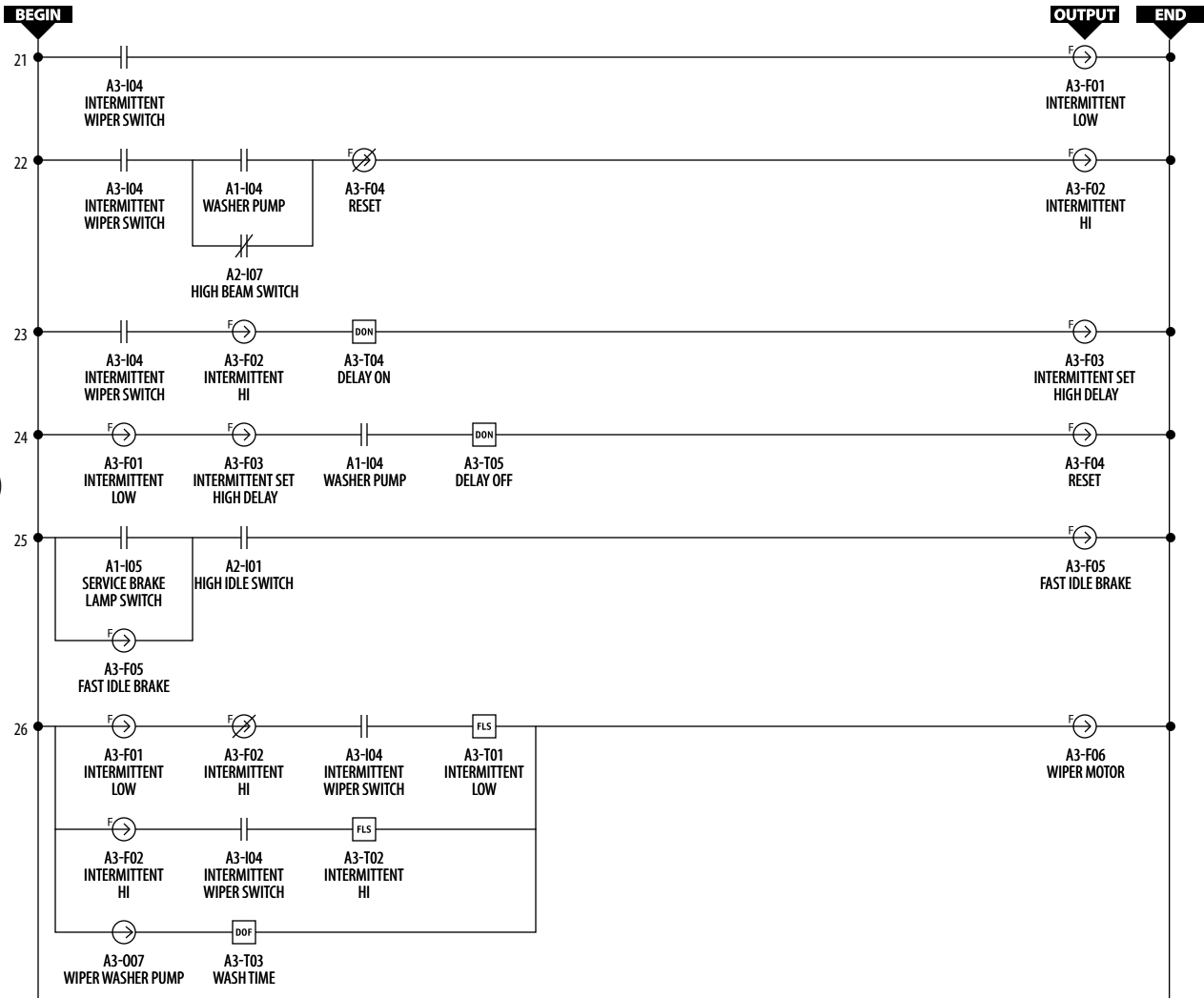



PORT 3 OUTPUTS

Caterpillar C7 & Cummins ISB
2002 Emission Standard Engines

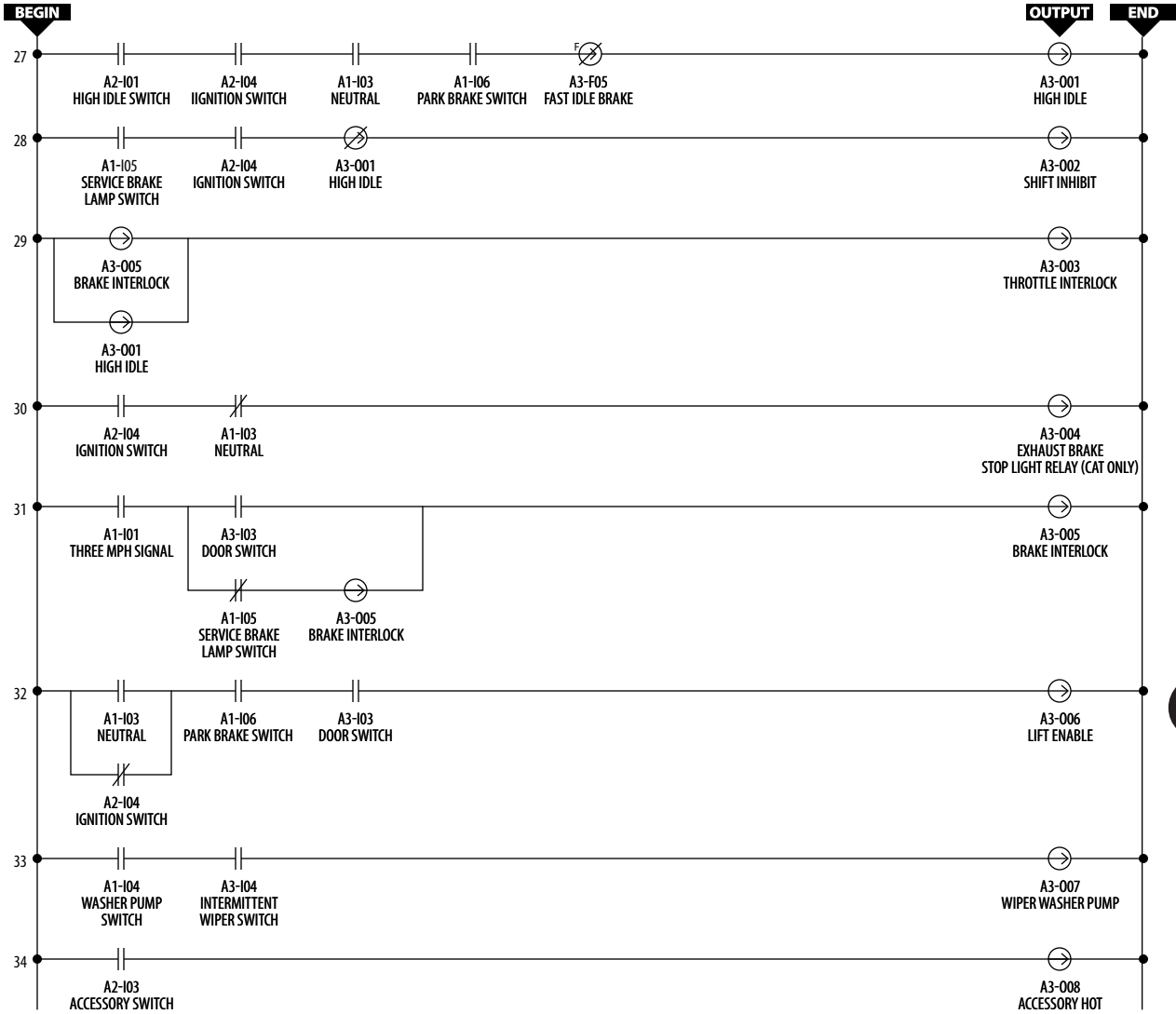

(FLORIDA) LADDER LOGIC DIAGRAMS

Caterpillar C702 & Cummins ISB02

2002 Emission Standard Engines

Symbols Key

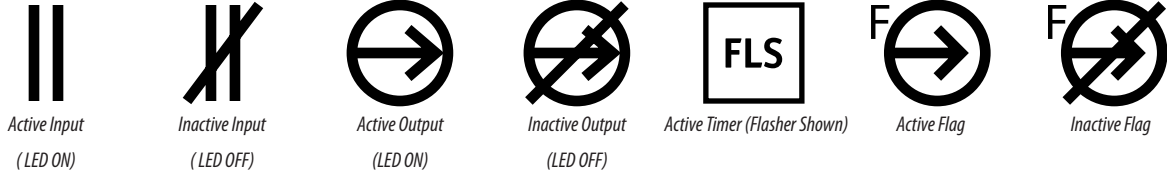

(FLORIDA) PORT 1 FLAGS

Caterpillar C7 & Cummins ISB

2002 Emission Standard Engines

690

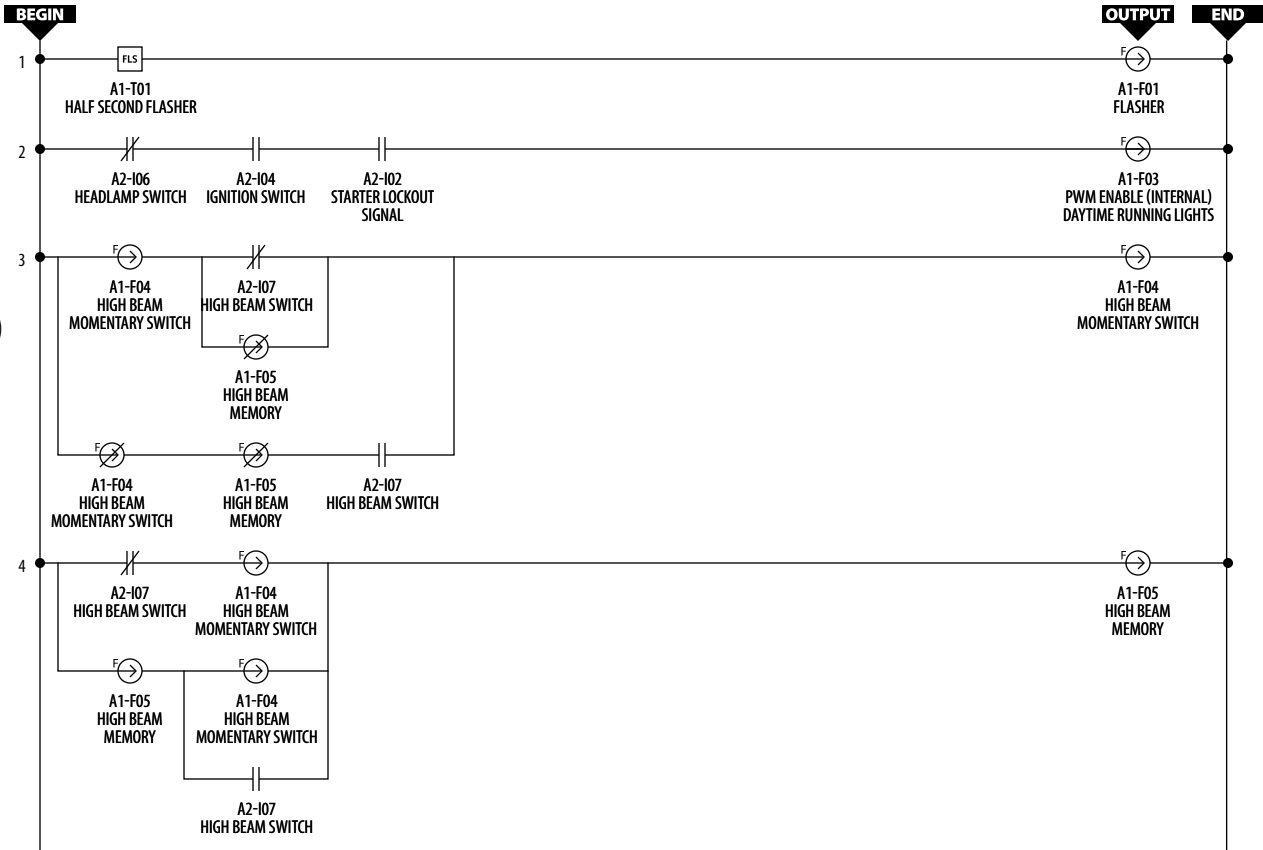



(FLORIDA) PORT 1 OUTPUTS

Caterpillar C7 & Cummins ISB
2002 Emission Standard Engines

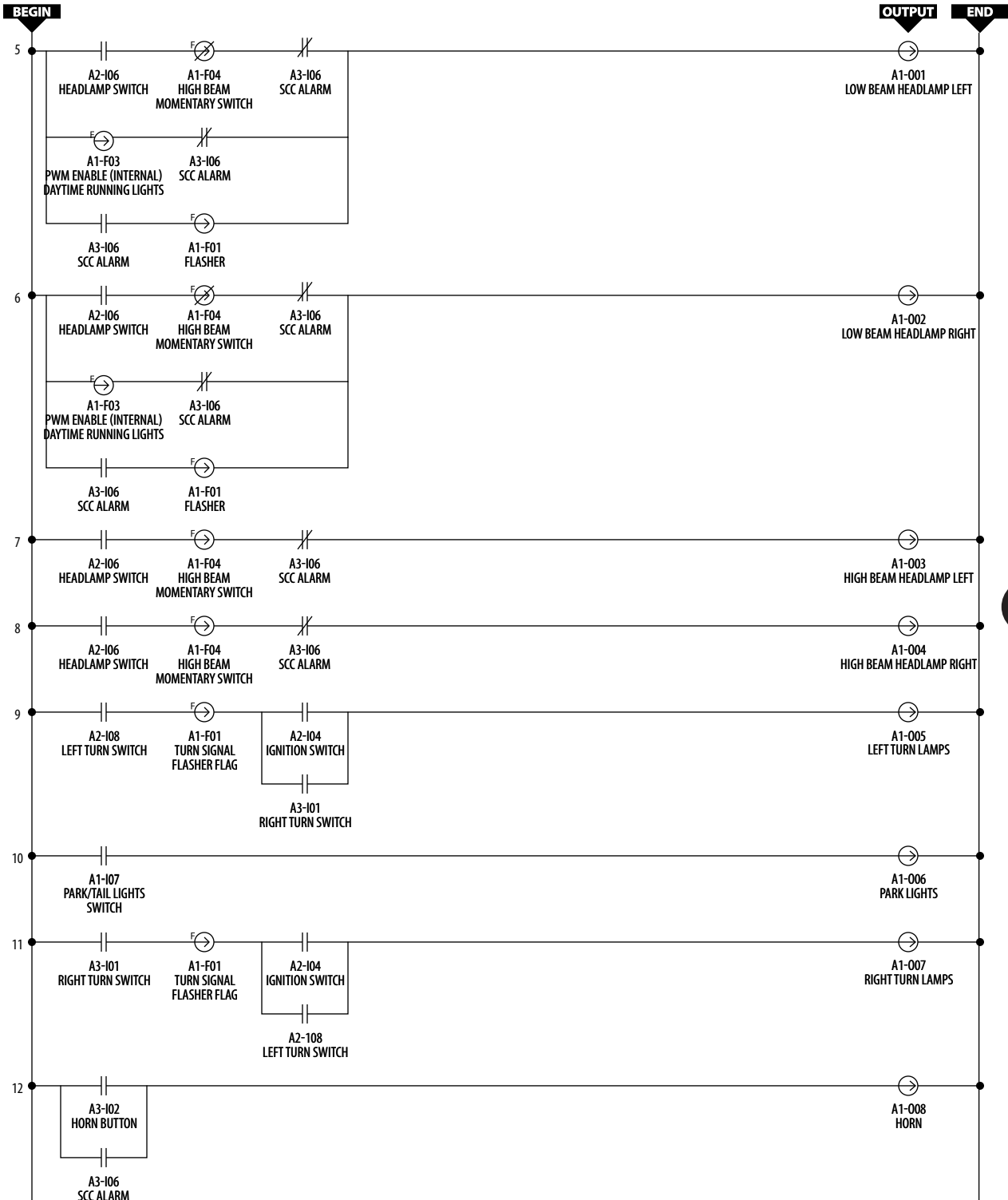

Symbols Key

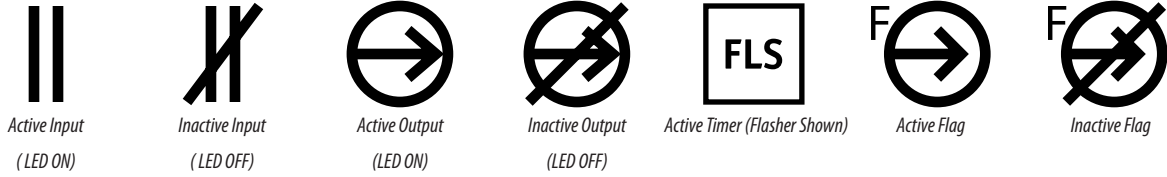

(FLORIDA) PORT 2 OUTPUTS

Caterpillar C7 & Cummins ISB
 2002 Emission Standard Engines

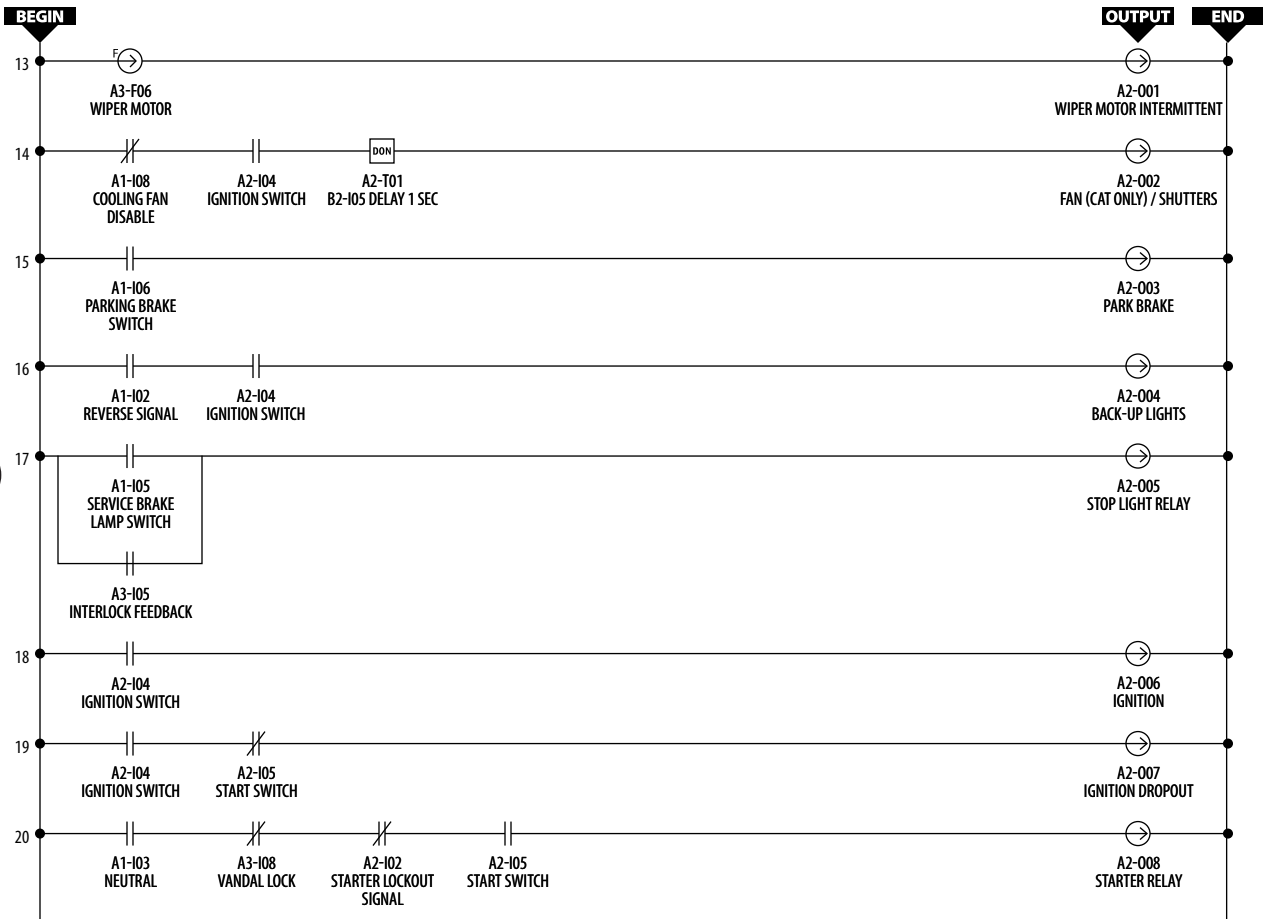





(FLORIDA) PORT 3 OUTPUTS

Caterpillar C7 & Cummins ISB
2002 Emission Standard Engines

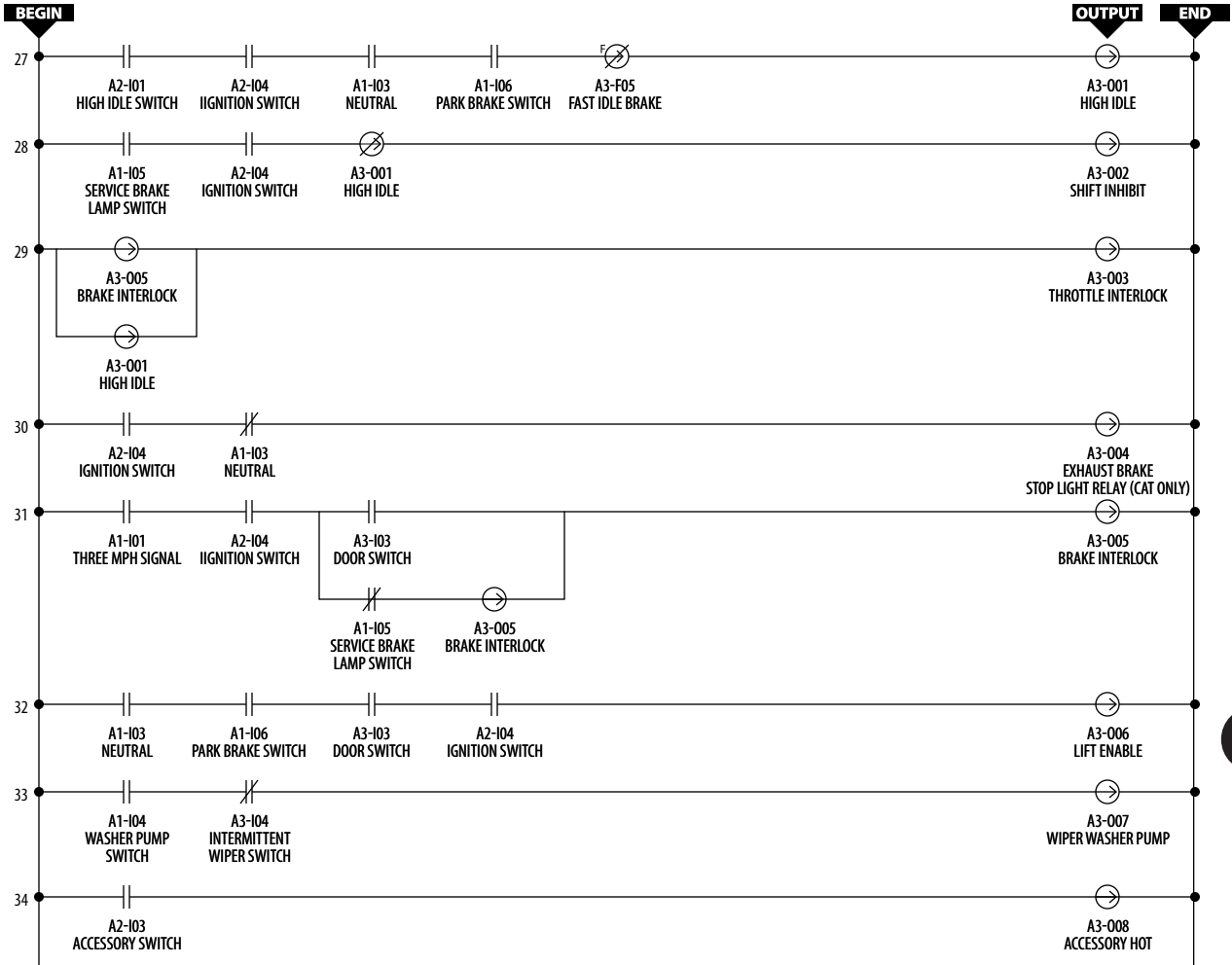

(WYOMING) LADDER LOGIC DIAGRAMS

Caterpillar C702 & Cummins ISB02

2002 Emission Standard Engines

Symbols Key

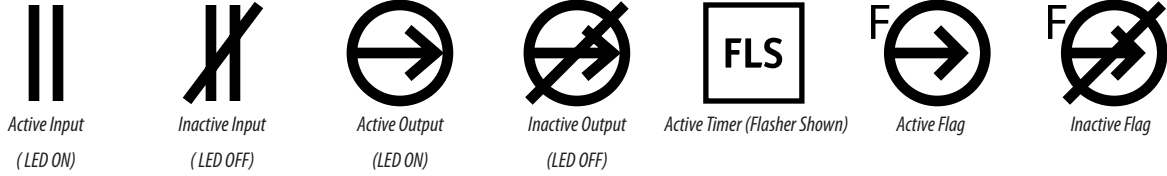

(WYOMING) PORT 1 FLAGS

Caterpillar C7 & Cummins ISB

2002 Emission Standard Engines

696

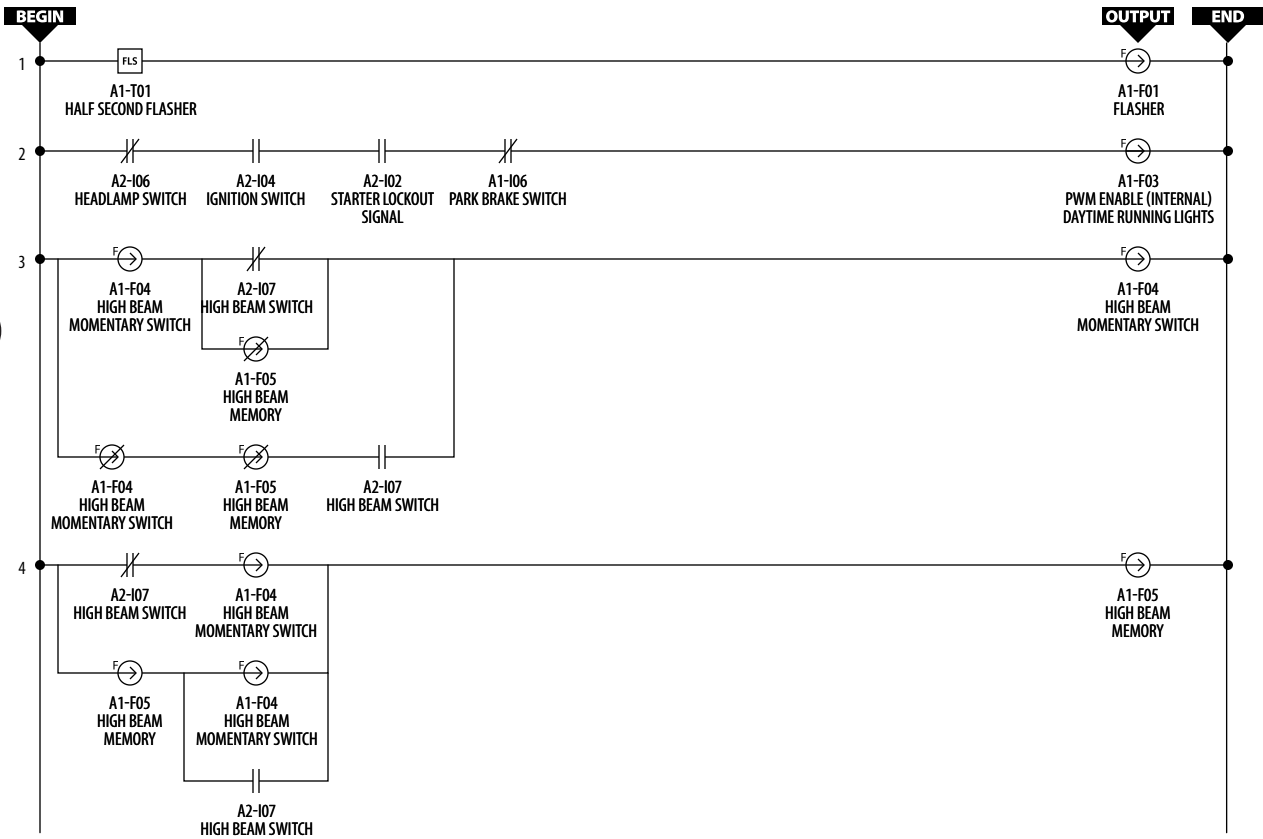



(WYOMING) PORT 1 OUTPUTS

Caterpillar C7 & Cummins ISB
2002 Emission Standard Engines

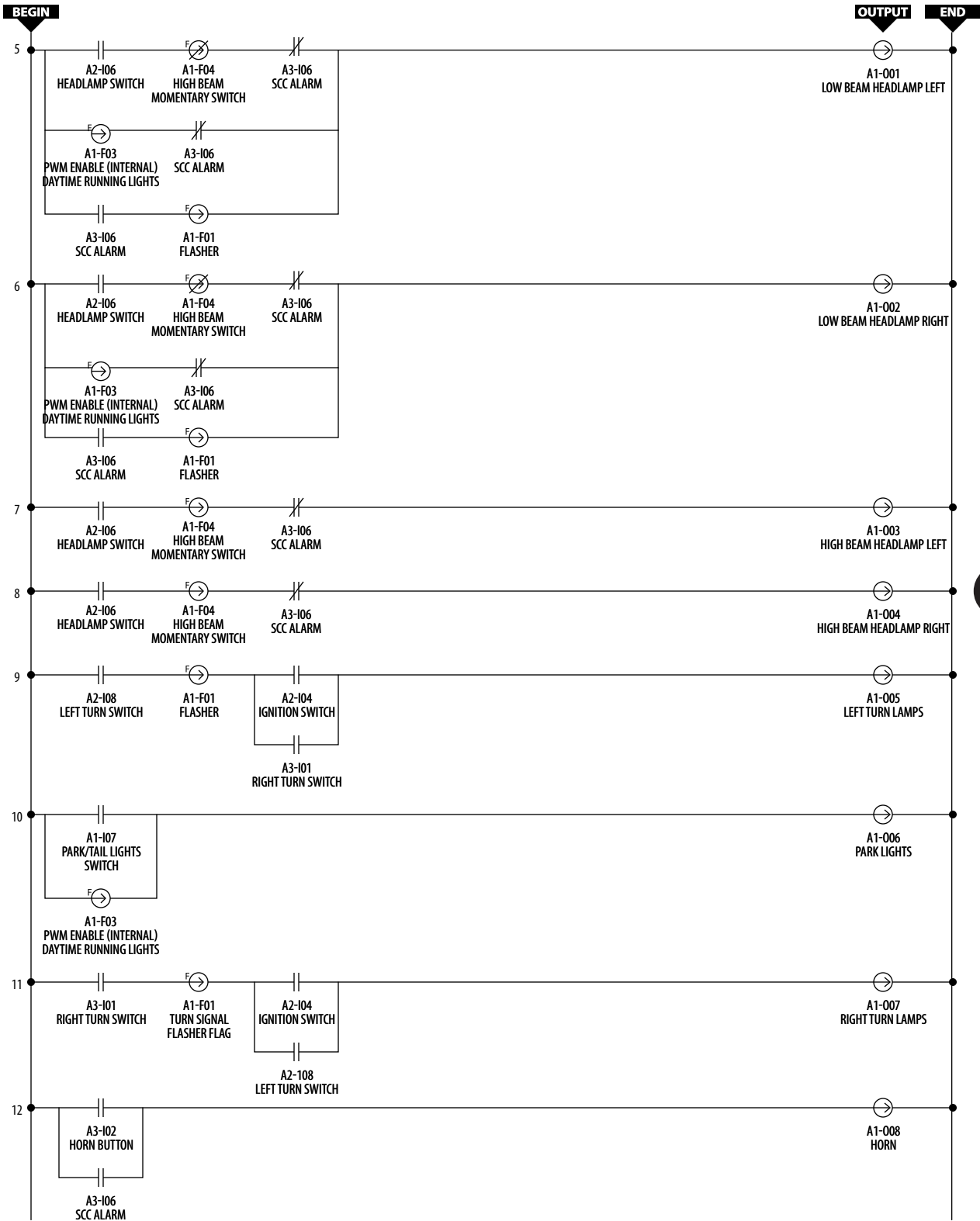

Symbols Key

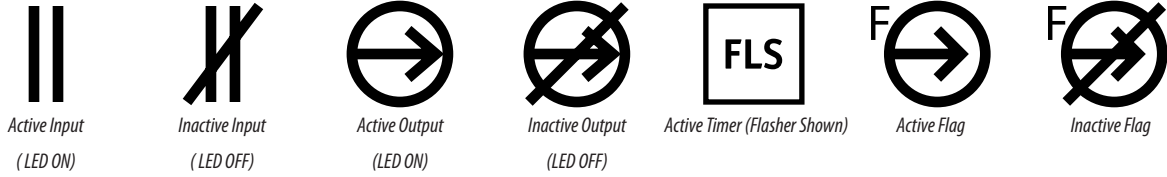

(WYOMING) PORT 2 OUTPUTS

Caterpillar C7 & Cummins ISB
2002 Emission Standard Engines

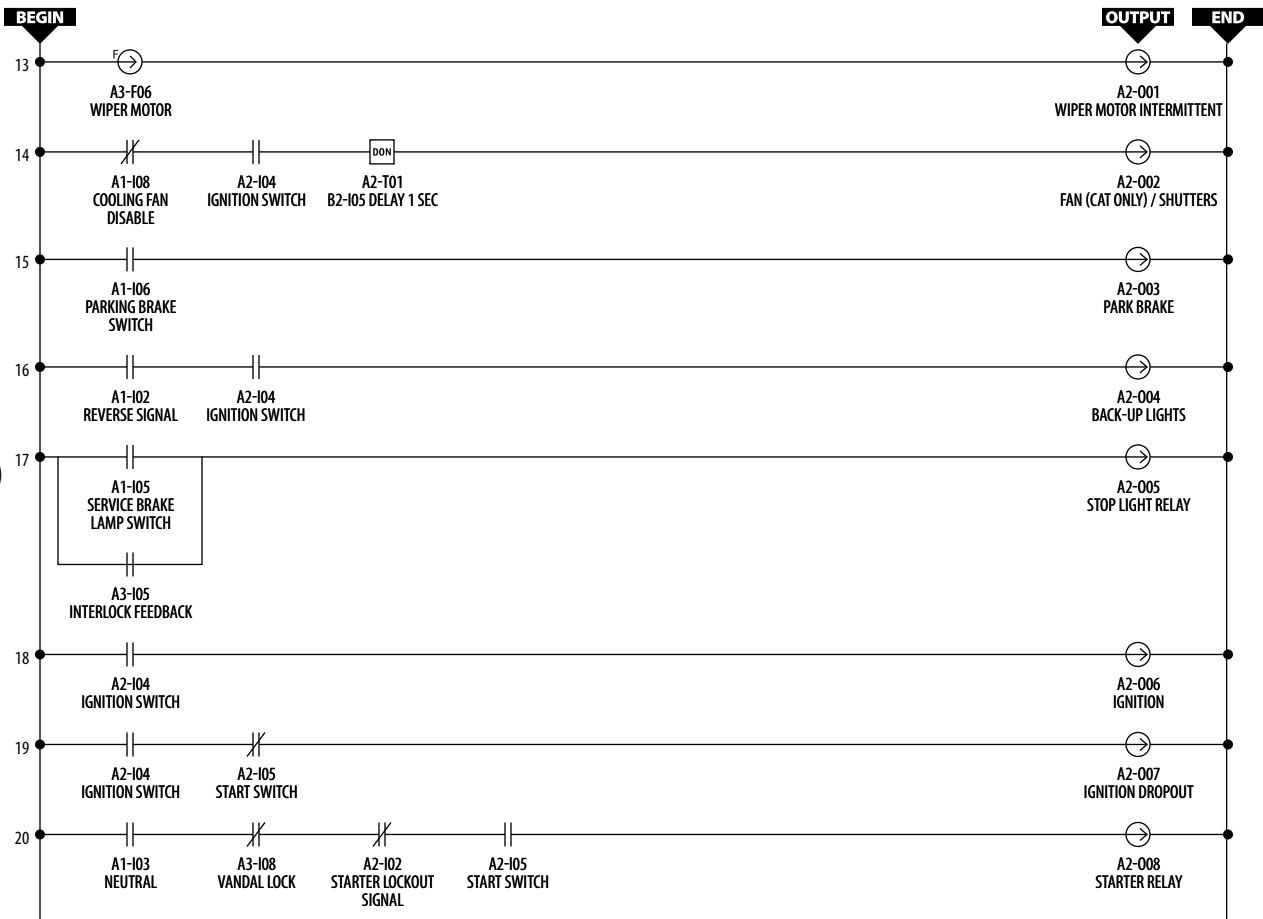

MULTIPLEX SYSTEM



Symbols Key

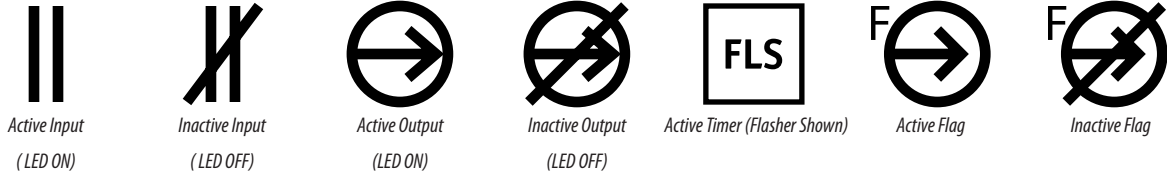

(WYOMING) PORT 3 FLAGS

Caterpillar C7 & Cummins ISB
2002 Emission Standard Engines

700

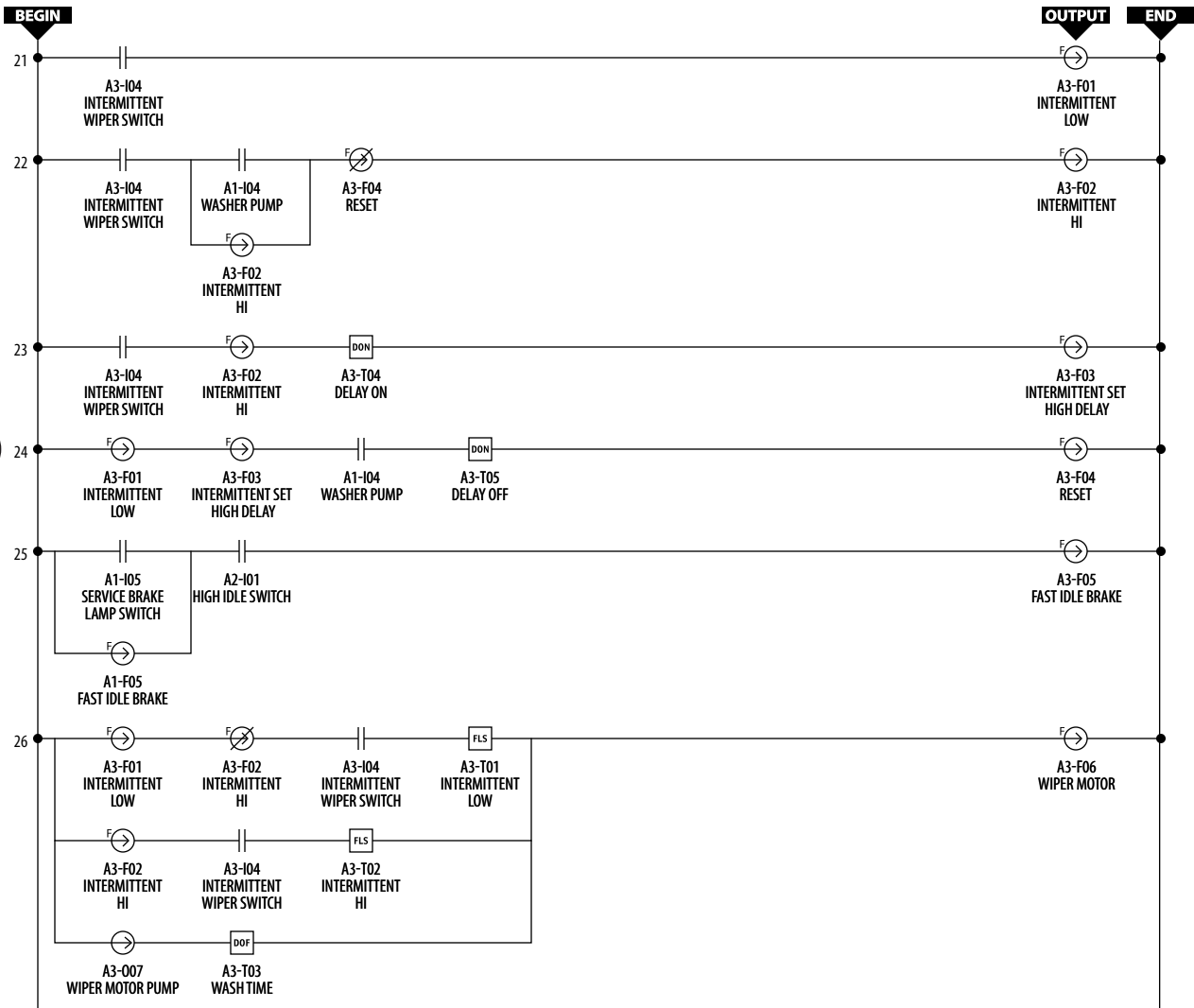



(WYOMING) PORT 3 OUTPUTS

Caterpillar C7 & Cummins ISB
2002 Emission Standard Engines

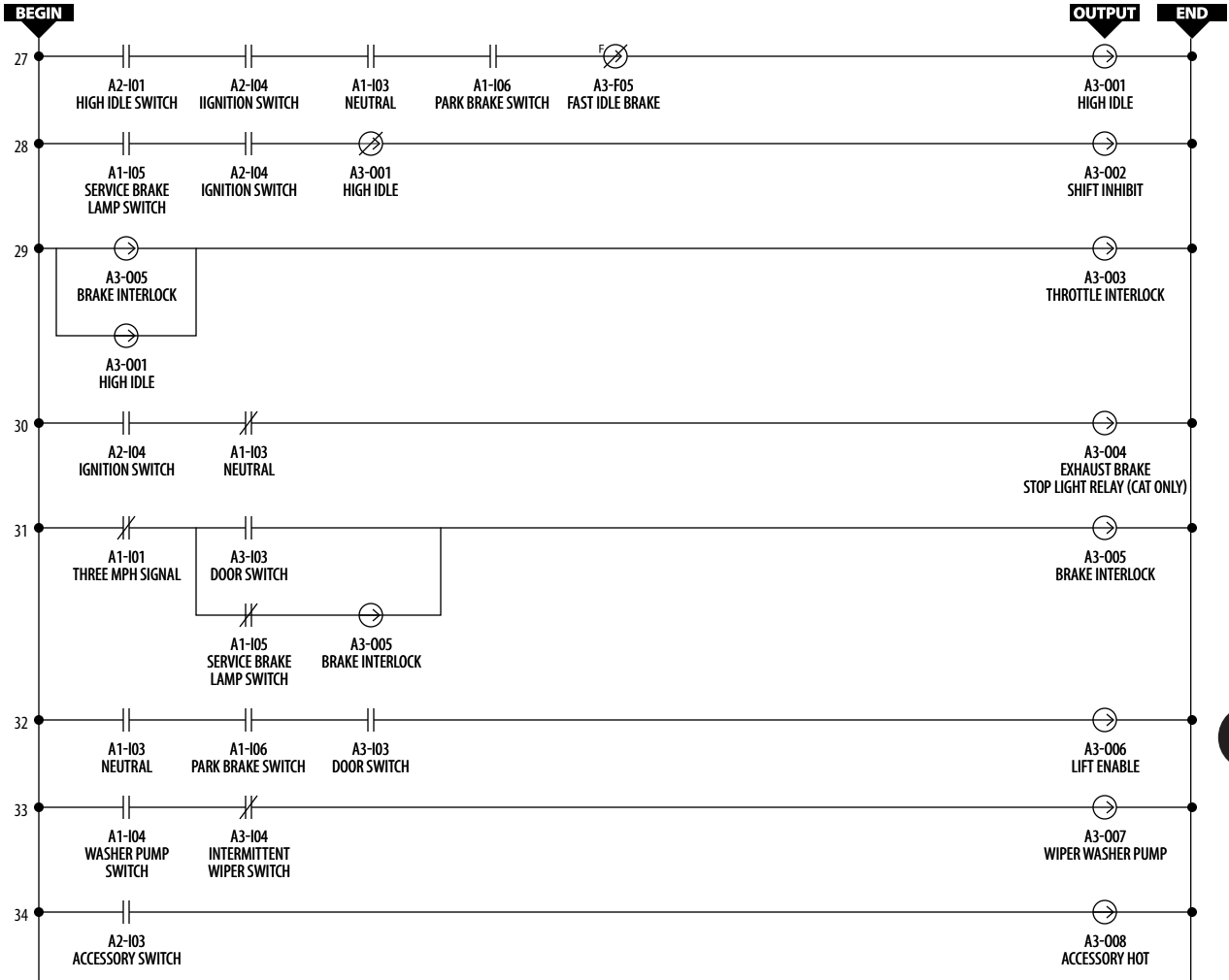



Troubleshooting In Diagnostic Mode

General Approach

A systematic approach to electrical troubleshooting of the Blue Bird Vision follows these general steps:

1. **Check the Inputs and Outputs Tables.** First determine if the affected circuit is one which interacts with or is controlled by the Multiplex system. Note the circuit's logical address (Zone-Port-Input/Output #) and its physical location (Connector / Port Pin). (If the issue is not a Multiplex circuit, refer to the Electrical System chapter and appropriate wiring schematics to troubleshoot conventionally.)
2. **Check the Output.** Operate the appropriate bus controls or switches to set the conditions which are required for the circuit's Output to be Active. (Refer to the Ladder Logic Diagrams to determine the required conditions.) If the MPX Module is generating an Active Output signal, but the circuit is not operational, at least part of the problem exists "downstream" of the Multiplex logic; probably in the Output's own load circuit. That is, since the Output signal is present, there is no reason at this point to suspect the "upstream" circuits of Inputs or other Outputs which are requirements of the desired Output. Troubleshooting efforts should be focussed upon the circuit beginning from the Output's Connector / Port Pin, through the load, and to ground.
3. **Check the Feedback.** To further verify that the problem exists in the load circuit, and to possibly gain additional information about its nature, create conditions (turn off switches, etc.) which should cause the Output to be Inactive. Then verify that the circuit's Feedback LED is on. If the Feedback LED is off when the Output is Inactive, an open is indicated in the load circuit, because the Feedback signal is not being conducted through the load. If the Feedback LED of a malfunctioning load circuit is on when the Output is Inactive (as it is in a correctly functioning circuit), the Feedback signal is being conducted, and you at least have an indication of continuity. If the Feedback LED is on while the Output is Active, a short in the load circuit is indicated.
4. **Check Each Requirement.** If the desired Output is shown by the MPX Module to be Inactive when it should be Active, the problem should be assumed to be "upstream" of the Output signal; at least one of the conditions (Inputs) required for an Active Output signal is absent. Referring to the Ladder Logic Diagrams, begin checking each requirement's LED to verify it is correctly Active (on) or Inactive (off). If a discrepancy is found, a malfunction is indicated "upstream" of that point in the logic (for example, a failed Input). Thus, comparing the states of the MPX Module's LEDs against the requirements of the Ladder Logic Diagrams enables the technician to quickly "narrow down" the source of the problem.

As you proceed, remember that:

- The Logic Line for a particular Active Output may require that certain Inputs are Active (LED on) while other Inputs are *Inactive* (LED off). It is helpful, therefore, to think of each item encountered on the Logic Line as a “statement” which is either *true* or *false* (This Input active=true; This Input inactive=true; This Input inactive=false). You seek to find and correct the false “statements.”
- The set of requirements for an Active Output may include requirements that other Outputs—which have their own Logic Lines—are either Active or Inactive. In such cases, the required Output states must also be investigated according to their own Logic Lines.

Troubleshooting Tree

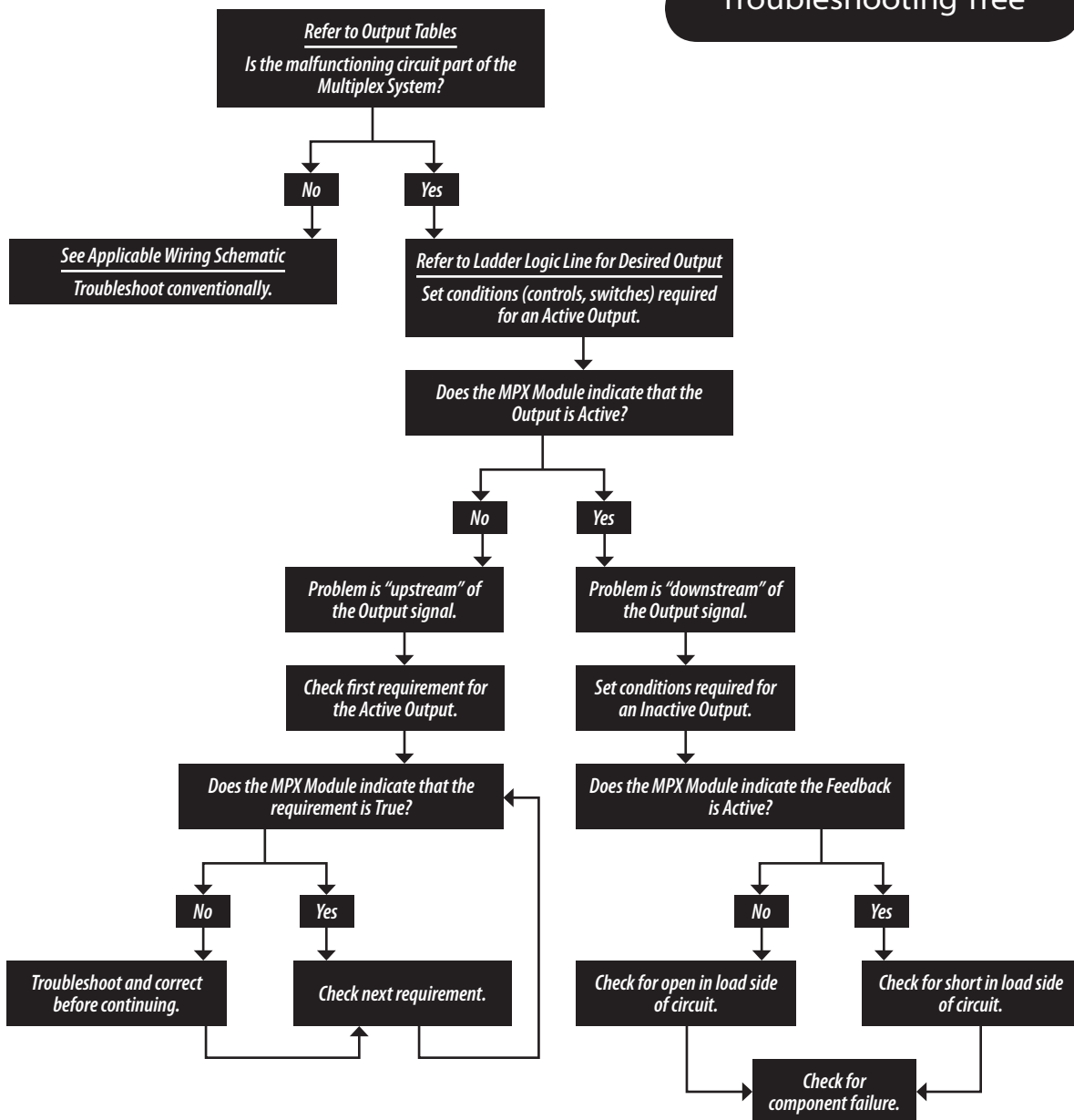

**Multiplex Terms:**

Multiplex: A way of transmitting multiple lines of communications (signals) simultaneously on one data line. This is similar in principle to the J1939 wiring harness which connects the engine, transmission, and ABS electronic modules together, providing an multiple communications between their respective electronic control modules. The Vision's Multiplex system uses a module containing microcomputer technology and electronic switching devices to provide a modern method of power distribution, circuit control, and circuit protection using.

MPX: Blue Bird's abbreviation for Multiplex.

Hard-wiring: A conventional method of routing current from an electrical source to a load and back to the source using copper wire, switches, relays, circuit breakers, fuseable links, fuses and other non-electronic components.

MPX Input: Typically a ground or 12 volt signal supplied to the MPX module, necessary for the MPX Module to produce an Output. An example of an Input is the hard wired ground signal the turn signal switch provides to the MPX module when the turn signal is switched on. The programming of the MPX Module can require that a particular Input be either active (on) or inactive (off) in order to generate a particular Output.

Active Input:  An Input which is in an "ON" state when received by the MPX Module. When troubleshooting, a active input symbol in the Logic Diagram indicates the LED in question should be ON to satisfy the requirement of the Output.

Inactive Input:  An Input which is in an "OFF" state when received by the MPX Module. When troubleshooting, an inactive input symbol in the Logic Diagram indicates the LED in question should be OFF to satisfy the requirement of the Output.

Output: A 12 volt or ground signal available at a physical output pin on the MPX Module. The Output is the end result of the functionality of the MPX module after *all* the requirements have been satisfied.

Active Output:  An Output that is "ON" or "True". An Active Output is providing voltage or ground for a downstream load. When troubleshooting, an active output symbol at the right end of the Logic Diagram indicates the LED in question should be ON when all the requirements of the Logic Diagram are satisfied.

Inactive Output:  An Output that is "OFF" or "False." An inactive Output is not providing voltage or ground for a downstream load. When troubleshooting, an inactive output symbol at the right end of the Logic Diagram indicates the LED in question should be OFF when all the requirements of the Logic Diagram are satisfied.

Flag:  An Output that is internally generated by the MPX Module, but which is not directly indicated on the troubleshooting LEDs. A Flag may be thought of as a programmatic function of the MPX Module logic. See Troubleshooting Principles, below, for more information.

Logic Diagram: A diagram describing which requirements are necessary for the MPX module to provide particular Outputs.

Logic Line: One horizontal path of the Logic Diagram. Each Logic Line leads to a single true Output located on the far right of the line. Along the path are icons indicating the requirement for that Output to be true. Depending on the programmed circuit logic for that particular function, a Logic Line may have only one requirement (Input) or several. Each requirement and Output on the Logic Line is identified by a description and an LED address.

LED Addresses: An alpha-numerical code which denotes which arrangement of LEDs on the MPX Module is associated with a particular Input or Output.

Connector/Pin Addresses: An alpha-numerical code which denotes which physical connector pin on the MPX Module is associated with a particular Input or Output.

Troubleshooting Principles:

About Flags

A Flag is an Output that is internally generated by the MPX Module. Just as with any other Output, a Flag is generated when a set of requirements (Inputs) are true. Being an internal signal, however, a Flag has neither a physical Output pin nor a voltage or ground signal associated with it that can be directly checked by the technician. A Flag therefore, can be thought of as an internal function, which may in turn be used as a requirement on other Logic Lines.

The troubleshooting LEDs only indicate the active or inactive state of Outputs and Inputs. They do not display the state of Flags. Therefore, Flags are verified by a process of elimination. When troubleshooting a logic diagram that results in a Flag, the technician uses the troubleshooting LEDs to verify the required state of Inputs and Outputs required for the Flag to be active. When all of the Flag's requirements have been verified, the technician must assume that the Flag has been generated and that it is active.

If the Flag occurs as one of the requirements for a physical Output that can be verified by an LED, the troubleshooting LEDs can be used to confirm that all requirements *except* the Flag are satisfied. If all the verifiable Inputs are true, yet the desired Output does not occur, then the technician could logically assume the Flag is suspect. The technician would then look for a Logic Line that ends in the suspect Flag. If there is one, he would proceed to verify the requirements for that Flag to be active, and so on. If all the verifiable conditions check out correctly, and yet the desired output is not achieved, then the functioning of the MPX module would be suspect. Blue Bird



recommends contacting your Blue Bird service source to confirm your troubleshooting before replacing a Multiplex module.

Two of the circuits on the 2008 model Visions have a more complex MPX logic than on previous models, and serve as examples of the troubleshooting of circuits involving Flags: The high beam headlight logic, and the intermittent wiper logic. Both of these incorporate multiple logic lines which generate flags that are in turn used as requirements (Inputs) on other Logic Lines. Only when all the Logic Lines involved have been satisfied, will a voltage be provided by the MPX module to energize the circuit.

Flag Example: Headlights

The high beam switch used on the new steering column for the 2008 Visions is a momentary switch with a single Output. Thus, the headlights cycle from low beam to high beam, and then back to low beam, with an identical signal from the high beam switch. This is where the MPX module logic comes into play. Referring to Logic Line number 7, note that two requirements are indicated for the MPX module to provide a physical Output for the high beam headlight left. (The logic for left and right high beam headlight is identical.)

With the headlight switch on (active), the A2-I06 headlight switch input requirement is satisfied. However, for the MPX module to provide a high beam headlight Output (A1-O03), the high beam momentary switch Flag (A1-F04) must be active. To verify the requirements for the active Flag, you would locate the A1-F04 Flag in the Output column on one of the other Logic Lines. Logic Line number 3 is the one which describes the requirements for the high beam momentary switch Flag (A1-F04) to be active. Studying the requirements for this Flag becomes somewhat more involved because of the use of multiple Flags occurring not only on Logic Line number 3, but also on Logic Line number 4.

Referring to Logic Lines 3, 4, and 7, note that there are only two physical inputs that a technician can actually verify with the LEDs: The headlight switch (A2-I06) and the high beam switch (A2-I07). If these Inputs are verified, yet the high beam headlight left is not active, it can therefore be logically assumed that one of the flags is faulty and the MPX module would be suspect. Blue Bird advises contacting your Blue Bird service source to verify your troubleshooting before replacing a Multiplex module.

Flag Example: Wiper motor intermittent A2-001 (Logic Line 13)

This Logic Line is another example of one which involves Flags, and therefore may require a process of elimination when troubleshooting. Logic diagrams 13, 21, 22, 23, 24, 26, and 33 all have a role in providing an intermittent wiper with two intervals. A similar troubleshooting methodology would be used.

Troubleshooting Example

The following example steps through a typical examination of a Ladder Logic diagram, using the Vision MPX Simulator for illustrative purposes. DoubleClick the VisionMPXSimulator.exe icon to launch it.

The Problem. This example assumes a problem with starting the bus. It will walk through an investigation of the Multiplex logic which affects starting.

1. **Refer to Input/Output Tables.** The tables reveal that the Multiplex system does indeed contains logic affecting several circuits having to do with starting the bus. The MPX Module receives Inputs named Ignition Switch, Neutral, Vandal Lock, Starter Lockout Signal, and Starter Switch. Outputs are generated by the MPX Module named Ignition, Ignition Dropout, and Starter Relay. Often, by merely considering these listings we can gain “hints” regarding how the Multiplex system comes into play: For example, it is easy to “guess” that the Starter Lockout Signal must be Inactive in order to start the bus.

In this scenario, we’ll assume the starter is not turning, and therefore begin our investigation with the Starter Signal Output. We note that the physical pin location for this Output is AA-114 (Connector A, pin number 14). The Outputs Table lists the logical address of the Starter Relay Output as A2-008 (Port 2, Output number 8), and also shows that that Output is on line #20 of the Ladder Logic diagrams.

Input Tables

Multiplex Inputs Table

	Circuit Description	Input LED	Connector / Port-Pin
1	Accessory Switch	A2-103	AC-003
2	Brake Light Switch	A1-105	AB-111
3	Diagnostic Switch	A3-107	AC-015
4	Door Signal	A3-103	AC-011
5	Fan, Cooling Disable (Car only)	A1-108	AA-108
6	Headlight Switch	A2-106	AC-006
7	High Beam Switch	A2-107	AC-007
8	High/Fast Idle	A2-101	AC-001
9	Horn Signal	A3-102	AC-010
10	Ignition Switch	A2-104	AC-004
11	Interlock Feedback	A3-105	AC-013
12	Neutral Signal	A1-103	AB-107
13	Park/Tail Light Switch	A1-107	AA-004
14	Park Brake Switch	A1-106	AB-012
15	Reverse Signal	A1-102	AB-004
16	Speed Signal	A1-101	AB-003
17	Starter Lockout Signal	A2-102	AC-102
18	Starter Switch	A2-105	AC-005
19	Turn Signal, Left	A2-108	AC-008
20	Turn Signal, Right	A3-101	AC-009
21	Vandal Lock	A3-108	AC-016
22	Washer Pump Switch	A1-104	AB-108
23	Intermittent Wiper Switch	A3-104	AC-112
24	SCC Alarm	A3-106	AC-014

Output Tables

Multiplex Outputs Table

	Circuit Description	Output LED	Connector / Port-Pin
1	Accessory Hot	A3-008	AB-116
2	Back up Lights	A2-004	AA-107
3	Brake Interlock	A3-005	AB-015
4	Fan Control Power (Car only)	A2-002	AA-103
5	High/Fast Idle	A3-001	AB-001
6	Headlight, High Left	A1-003	AA-110
7	Headlight, High Right	A1-004	AA-112
8	Headlight, Low Left	A1-001	AA-102
9	Headlight, Low Right	A1-002	AA-106
10	Horn	A1-008	AB-114X
11	Ignition	A2-006	AA-111
12	Ignition Dropout	A2-007	AA-113
13	Park Brake	A2-003	AA-105
14	Park Lights	A1-006	AB-106
15	Shift Inhibit Signal	A3-002	AB-005
16	Lift Enable	A3-006	AB-021
17	Ex. Brake Stop Light (Car only)	A3-004	AA-09
18	Starter Relay	A2-008	AA-114
19	Stop Lights Relay	A2-005	AA-109
20	Throttle Interlock	A3-003	AB-009
21	Turn Signal, Left	A1-005	AB-102X
22	Turn Signal, Right	A1-007	AB-110X
23	Wiper Washer Pump	A3-007	AB-122
24	Intermittent Wiper Motor	A2-001	AA-101
25	Shutters	A2-002	AA-103

2. **Check the Output.** To check the status of a desired Output, we must first put the MPX Module in Diagnostic Mode and cycle it to display Outputs for the appropriate Port. Press the Diagnostic Switch repeatedly until the Port 2 LED (in the PORT row) is on, and then until the Output LED (in the I/O row) is on. Turn the ignition switch to the start position and note whether the #8 LED (in the CH# row) comes on when attempting to start the engine. By verifying an active output first, you are in fact, verifying all input requirements are correct. If any one requirement does not match the logic line the MPX module will not activate the output.

3. **Check the Feedback.** If the A2-008 LED lights when trying to start the engine, we know that the MPX Module is generating an Active Starter Relay Output. If the starter failed to operate despite the Output being Active, the cause would most likely be “downstream” of the multiplex system, in the load circuit itself (i.e.; Starter Relay, Solenoid, etc.) That is, there would be no reason at this point to suspect the various circuits which are required for an Active Starter Relay Output, because the Output is Active. Even in such a case, though, further insight into the nature of a problem may be gained by checking the Feedback LED.

Press the Diagnostic Switch once more to cycle the MPX Module to monitor the A2-008 Feedback LEDs. (Note the Output and Feedback use the same LED address.) In our scenario, if the Starter Relay’s Feedback LED were on while its Output is Active, it would, therefore, be reasonable to suspect a short to ground in the Output load circuit or a failed MPX Module.

The most likely cause for an Output LED’s being on while the Feedback LED is on is that a short to ground has been detected by the MPX Module. In that case, a MOSFET (the electronic switching device and circuit protector inside the Module) will trip (open the circuit) and deactivate the Output, thus protecting the circuit from damage. The Output circuit connector should be removed and a conventional short to ground test with a voltmeter should be conducted.



	S	A	B	C	D	L	
ZONE	●	●	●	●	●	●	
	1	2	3				
PORT	●	●	●				
	IN	OUT	FB				
I/O	●	●	●				
	1	2	3	4	5	6	7
CH#	●	●	●	●	●	●	●

● LED on
● LED off

If a short to ground is not indicated by the above condition (an Output LED's being on while the Feedback is on), the MPX Module is suspect. A physical test at the output pin could be conducted. It is important to bear in mind that the MOSFET will not reset simply because the short has been removed or the connector containing the circuit in question has been removed from the MPX Module. If a short to ground has occurred, the Output will continue to be deactivated by the MOSFET in its tripped (open) state. It can be reset by turning the ignition switch off, or by causing one of the required Inputs for that circuit to be inactive. One could misdiagnose a correctly functioning MPX Module or even damage the Module by checking for voltage on an Output that has been shorted to ground without first performing these steps:

1. turn the ignition switch off.
2. Isolate the short.
3. turn the ignition switch on.
4. verify that all requirements for an active Output are correct (true).
5. Refer to the output chart to see if the Output should be 12 volts or ground.
6. Measure the Output at the correct terminal for the correct condition with a voltmeter.

If the physical output is not found to be correct by conducting the above test, the MPX Module is suspect. Confirm proper voltage and grounds at connectors D and E with a voltmeter. Consider consulting with a Blue Bird service source to confirm your diagnosis before replacing the MPX Module.

If, as is normal, the Feedback LED is off while the Output is Active, then the circuit should be operative. If not, there is an open on the Output circuit. Thus, in cases where the desired Output is Active, but the circuit is still inoperative, the Feedback LED can help indicate whether the probable cause is an open or a short.

But what if a desired Output is Inactive? Even then it is still good practice to check the Feedback LED before proceeding to verify the presence of each requirement for an Active Output. In our example, we know that if the Starter Relay Output is Inactive, we should see its Feedback LED on, indicating that continuity exists in the Starter circuit, and that it should become operative when the Output becomes Active. But if the Feedback LED were off while the Output is Inactive, then we would already have an indication of an open in the Starter circuit, and that the Starter will not work even when the requirements for an Active Starter Signal Output are met.

4. **Check Each Requirement.** At this point in our example, we assume that the Starter Relay Output is Inactive, and that the Feedback LED is on, as it should be. It is now safe to assume that any starting problem must be “upstream” of the load circuit itself. We must begin to systematically ensure that each of the requirements for the Starter Relay Output to be active is met. It is now time to refer to the Logic Diagram.

As indicated in the Output Table, Logic Line # 20 is the one which leads to an Active Starter Signal Output. Click the yellow tab at the upper left of the Vision MPX Simulator to reveal a scrolling list of the Logic Diagrams. Click the red down arrow to scroll down to line 20.

Reading from left to right, we see that the requirements for an Active Starter Signal are:

- The Neutral Signal Input at logical address A1-I03 must be Active.
- The Vandal Lock Input at A3-I08 must be Inactive.
- The Starter Lockout Signal Input at A2-I02 must be Inactive.
- The Front Start Switch Input at A2-I05 must be Active.

Our procedure, then, is to systematically set the controls which operate each of these requirements and verify their Active or Inactive status:

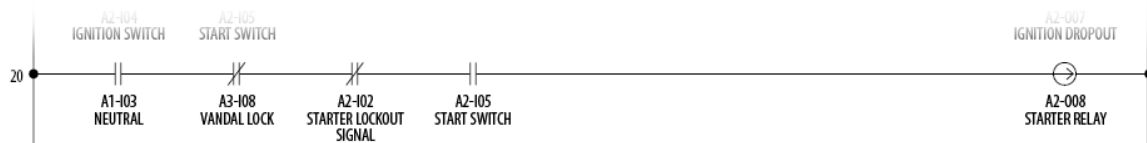

Logic Line 20 of the Logic Diagrams

4.1. Verify that the transmission is in Neutral. Press the Diagnostic Switch enough times to cycle the MPX Module LEDs to display Zone A Port 1 Inputs. If the #3 Input LED were not on, at least part of the problem would have already been isolated. In this case, you would then refer to the wiring schematic for the Neutral signal switch and troubleshoot that circuit. Locating a wiring schematic for a specific failure can be simplified by referring to the Input Tables. Locate the Input that has failed (in this case, the Neutral Signal, Line 12). The third column shows AB-107, indicating the Neutral Signal circuit connects to the MPX Module through the B connector pin number 7. Connectors A, B, and C of the MPX Module have dedicated wiring schematics. Referring to the wiring schematic index page, find that the AB Multiplex Module (Zone A Connector B) is located on sheet 11 (for Cummins ISB07). The circuit in question is located at pin 7 of the AB connector. Since the A1-I03 LED is on, the Input is Active as it should be, and we proceed to step 4.2.

4.2. Make sure the Vandal Lock is not on. This is an A3 Input, so the MPX Module needs to be cycled to indicate addresses for A3 Inputs. However, now we are looking for an *In*active Input, not an Active one. Verify that the #8 Input LED is off. If the A3-I08 Input LED were to stay on while the Vandal Lock was unlocked, it might be suggestive of a stuck or shorted Vandal Lock signal switch. Again, you would refer to the appropriate wiring schematic and troubleshoot that circuit.

4.3. The fourth requirement is also for an Inactive Input; the Starter Lockout Signal. The Starter Lockout Signal is generated by the engine ECU to prevent the starter from engaging if the engine is already running. Therefore, it is not an Input over which the Driver has direct control. He controls it indirectly by starting the bus. Put the MPX Module in its display mode for A2 Inputs and verify that the #2 Input LED is off. If it were on when the engine is not running, a diagnostic check of the engine ECU would be in order.

	S	A	B	C	D	L		
ZONE	●	●	●	●	●	●		
	1	2	3					
PORT	●	●	●					
	IN	OUT	FB					
I/O	●	●	●					
	1	2	3	4	5	6	7	8
CH#	●	●	●	●	●	●	●	●

The MPX Module is displaying A1 Inputs. Input #3 (Neutral Signal) is Active.

	S	A	B	C	D	L		
ZONE	●	●	●	●	●	●		
	1	2	3					
PORT	●	●	●					
	IN	OUT	FB					
I/O	●	●	●					
	1	2	3	4	5	6	7	8
CH#	●	●	●	●	●	●	●	●

The MPX Module is displaying A3 Inputs. LED #8 (Vandal Lock Signal) is off—satisfying a requirement for an Inactive Input.

	S	A	B	C	D	L		
ZONE	●	●	●	●	●	●		
	1	2	3					
PORT	●	●	●					
	IN	OUT	FB					
I/O	●	●	●					
	1	2	3	4	5	6	7	8
CH#	●	●	●	●	●	●	●	●

The MPX Module is displaying A2 Inputs. LED #2 is off, so the Starter Lockout Signal is Inactive.



4.4 Finally, the A2-I05 Start Switch Input must be Active. This is a signal from the ignition switch when it is turned to the Start position. The MPX Module is already displaying A2 Inputs, and the #5 Input LED is off. Press and hold the ignition switch and you will see that the #5 LED comes on while the switch is in the Start Position. If this did not occur, the ignition switch or its wiring would be suspect.

Notice also that as soon as the engine starts, the #2 LED (Starter Lock-out Signal, described above in Step 4.3) comes on and remains on until you click the ignition switch again to turn off the engine.

As the #2 Starter Lock Out Signal becomes Active, it no longer provides a correct requirement for the MPX Module to provide a Starter Relay Output. Therefore, when the engines starts, the MPX Module will deactivate the Starter Relay Output and the starter will disengage even if the driver keeps the ignition switch in the Start position.

At this point, you have verified the presence of a full set of conditions (Inputs) required for an Active Starter Signal Output, and the starting circuit should be functional. If you experiment with the MPX Simulator by changing any of the required conditions, you will see that when any of the requirements are not met, the A2-008 Output will not be Active, and the engine will not start. This example has shown that the Multiplex Diagnostic Mode can be used to quickly isolate the location of an electrical system malfunction in a circuit with which the MPX Module interacts. (For example, consider how much time might be spent in determining that the cause of a starting problem is a damaged parking brake switch, without the benefit of multiplex.) Note that the use of Multiplex does not negate or invalidate traditional means of tracing and troubleshooting circuits, but serves to eliminate much of the preliminary guesswork in determining which circuit(s) to investigate.

In a real-case scenario, only after verifying all the required conditions, yet still finding the Output to be Inactive and/or the circuit inoperative, should there be reason to suspect a failure of the MPX Module itself. Remember that all Input and Outputs can be verified using a multimeter at the associated Connector/ Port-Pin locations. In the unlikely case that you have thoroughly investigated the Multiplex Logic and have come to suspect a defective MPX Module, you may wish to contact your Blue Bird Distributor's service technicians for a second opinion verification of your troubleshooting.

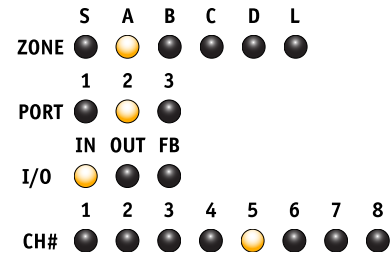

Still displaying A2 Inputs, LED #5 is on only when the ignition switch is in its momentary Start position. As soon as the engine starts, LED #2 (Starter Lockout Signal) comes on and remains on until the engine is switched off.

Shared Logic

To avoid confusion when reading Ladder Logic and troubleshooting, remember that the requirements shown on a Ladder Logic line are only requirements for the MPX Module to make the Output indicated at the end of the line Active. It is possible for other conditions to be required beyond the scope of the Multiplex system. In the present implementation of Multiplex one such "special case" is the Fast Idle logic, shown on line 27 of the Ladder Logic charts for the Blue Bird Vision with a Caterpillar engine.

The Active Fast Idle Output from the MPX Module is one of two signals required by the Caterpillar ECM before it engages Fast Idle. The other is a signal required by the engine ECU logic. The Caterpillar ECU, much like the MPX Module, also requires Two Active Inputs: An Active Neutral Input, and an Active High Idle Input from the MPX Module.

In other words, Logic Line 27 is correct for the MPX Module to generate an Active Fast Idle Output; but Neutral is also required by the engine ECM for it to cause High Idle to actually occur. In this sense, even though the MPX Module and engine ECM are separate processors which do not share programming, they work together to "share" the logical requirements for a particular function. The Active Fast Idle Output from the MPX Module alone does not cause the actual occurrence of High Idle; it serves as but one of the ECM's requirements.

