

Overview

Front and rear hydraulic disc brakes manufactured by ArvinMeritor are standard equipment. Two hydraulic systems come into play when the Vision's disc brakes are applied: The brake system, which is passive, and the power steering hydraulic system, which is pump driven. Although the two systems interact, they are separate closed circuits with separate fluid supplies. The component at which the two systems interact is the Bosch Hydro-MaxR™ master cylinder/booster assembly.

Under normal driving conditions with the engine running, the driver presses the brake pedal, actuating the HydroMaxR™ (mounted in the engine compartment against the driver-side firewall). The booster portion of the assembly receives hydraulic steering fluid and allows hydraulic pressure generated by the power steering pump to assist in actuating (boost) the master cylinder, which contains brake fluid.

A pressure switch mounted on the body of the brake booster monitors pressure in the hydraulic power steering system. If pressure is absent when brakes are applied (as when the engine is not running), the pressure switch activates an electric pump mounted on the underside of the brake booster body to provide brake boosting power. The BRAKES warning light on the driver's instrument panel is also activated.

When there is no boost pressure in the power steering hydraulic system, and no boost is being provided by the electric pump (as when the ignition switch is off), the hydraulic brakes still operate, but require significantly greater pressure at the pedal.

The master cylinder, power boosted by the power steering pump system, transfers hydraulic pressure to the Antilock Brake System (ABS) modulator, mounted on the frame cross member located just aft of the transmission above the front end of the driveline. The modulator distributes the pressure in the brake system to the master cylinders mounted on each wheel, according to control signals it receives from the ABS Electronic Control Unit (ECU), which is mounted inside the bracket which supports the transmission shift lever.

At each wheel, a wheel speed sensor detects the speed of the rotating wheel and sends a signal to the ECU. The ECU monitors these wheel speed signals and controls the modulator to adjust the braking pressure at each wheel individually, so as to maintain traction (avoid wheel lock) at all wheels.

Blue Bird Visions equipped with standard hydraulic brakes employ a cable-actuated drum-type parking brake installed on the rear of the transmission. The parking brake is not to be used as a normal service brake, but can be used to help stop the bus in an emergency situation.

Appendixes In This Chapter

Appendix 1: Hydro-Max Hydraulic Brake Booster and Master Cylinder. This Bosch publication details the operation of the master cylinder & booster assembly, and includes troubleshooting information.

Appendix 2: Hydraulic ABS. Meritor Wabco Maintenance Manual 39. Detailed information on the ABS Module and other ABS components. Includes troubleshooting using blink codes and Meritor Wabco Toolbox diagnostic software.

Appendix 3: Four Piston Quadraulic Disc Brake Caliper. Meritor MM-2075. Detailed information on disassembly, inspection, and reassembly of the brake calipers.

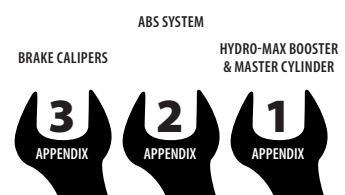

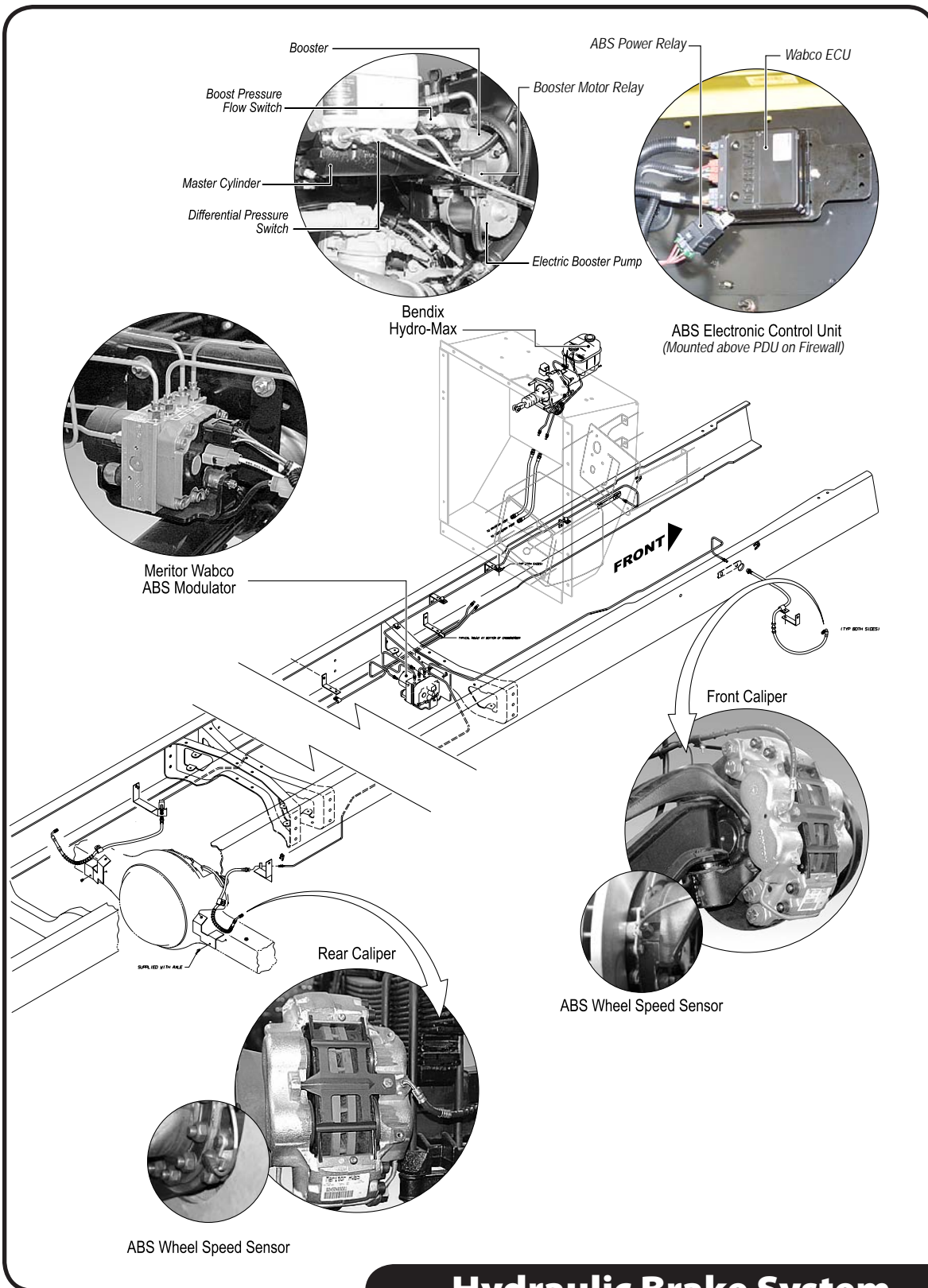

Hydraulic Brake System



Maintenance

Servicing the hydraulic brake system involves procedures at several levels.

- Regularly scheduled maintenance tasks such as inspection, fluid replenishment, and linkage lubrication. See the Hydraulic Brakes Maintenance chart below (also included in the Brakes chart in the Specs & Maintenance Chapter).
- Replacement and/or servicing of normal wear parts, such as brake pads and rotor surfaces, as they approach their service life specifications. These procedures must be performed according to the manufacturers' specifications. References are provided in the various component sections that follow.
- More involved overhaul or rebuild procedures for major components; for example, replacement of seals in the caliper(s). These also must be performed according to manufacturers' procedures. Appropriate references are provided in the respective component descriptions below.
- When any part of the brake system's hydraulic fluid circuit is disassembled or loosened, the system must be bled before returning the bus to operation. This must be done according to procedure for the Meritor Wabco ABS system. See Hydraulic Brakes Appendix 2 (Meritor Wabco publication: Hydraulic ABS Maintenance Manual no. 39). Arvin Meritor also provides additional information online at www.arvinmeritor.com.

Hydraulic Brakes Maintenance

INTERVAL: MONTHS/1000 MILES
whichever occurs first

OPERATION	1 / 3,000	3 / 5,000	3 / 24,000	6 / 6,000	6 / 10,000	12 / 12,000	12 / 24,000	24 / 24,000	NOTES
Hydraulic Brakes									
Check fluid level	•								Use DOT-3 brake fluid.
Inspect booster & master cylinder			•						Inspect for signs of leakage or damage.
Adjust park brake lever				•					Adjust engagement pressure at the lever to 90-100 lbs.
Hydraulic Brake Wheel Ends									
Inspect calipers				•					Inspect for signs of leakage or damage.
Lubricate calipers		•							See Meritor documentation.
Check pad thickness	weekly or as needed in severe applications								Minimum 1/8 inch (3.175 mm).

Master Cylinder

The master cylinder assembly is mounted directly to the body of the hydraulic booster. These two components are mounted as a unit in the engine compartment on the driver-side firewall.

The fluid reservoir for the brake system is part of the master cylinder assembly, and contains DOT 3 brake fluid. When the brake is operated, pistons in the master cylinder drive brake fluid that it receives from the reservoir into the brake lines, transferring the mechanical force to the brake calipers at each wheel.

The master cylinder is internally divided into two hydraulic circuits; one for the front brakes, and one for the rear. The fluid reservoir is similarly divided, thus its two fill caps. Hydraulic leakage or complete failure in one system does not affect function of the other system.

An electric sending unit is mounted to the side of the master cylinder. If significant pressure difference is detected between the front and rear brake circuits, the sensor sounds a warning buzzer in the driver's area and turns on the BRAKES light on the instrument panel.

Troubleshooting

Symptoms that may indicate master cylinder failure include, but are not limited to:

- Brake fluid leakage from between the master cylinder and booster.
- Hard pedal. Excessive pressure is required at the pedal to apply brakes.
- Excessive pedal travel. Pedal goes to the floor.
- Actuated pedal does not return.
- Brake drag.

For a more detailed description the master cylinder's operation, as well as troubleshooting guidelines, see Hydraulic Brakes Appendix 1 (Bosch publication: HydroMax Hydraulic Brake Booster and Master Cylinder). If the master cylinder is determined to be malfunctioning, it must be replaced. Replacements are available from your Blue Bird Parts Distributor.

Removal

The master cylinder may be unbolted from the booster without removing the entire master cylinder/booster combination as a unit. However, it is possible that when the master cylinder is unbolted from the booster, the booster's internal spring may cause its o-ring seal to pop out, spilling hydraulic fluid. Thus, it is a good practice to take measures to catch the hydraulic fluid in case this occurs.

1. Park the bus on a level surface with parking brake on.
2. Disconnect the negative terminal of the battery.
3. Disconnect the harness wire from the master cylinder's balance sending unit.



4. Position a suitable container under the master cylinder/booster assembly.
5. Disconnect the two hydraulic lines from the master cylinder.
6. Remove the four bolts and nuts which fasten the master cylinder to the booster and remove the master cylinder.

Reinstallation

Install the master cylinder by reversing the removal procedure.

1. Mount the master cylinder to the booster and tighten the four bolts to 25–30 ft. lbs. (33.9–40.7 Nm).
2. Reattach the brake fluid lines and tighten the nuts to 200 in. lbs. (22.5 Nm).
3. After installation, the brake system must be bled before operating the bus. This must be done according to procedure for the Meritor Wabco ABS system. See Brakes Appendix 2 (Meritor Wabco publication: Hydraulic ABS Maintenance Manual no. 39).

Booster

The brake booster is mounted directly to the front of the driver-side firewall in the engine compartment, and also serves as the support for the brake master cylinder.

During normal operation, fluid pumped by the hydraulic pump flows through the booster's inlet, throttle valve, and power piston, and then exits through the outlet port. When the brake pedal is applied, the booster's input rod activates the throttle valve, restricting flow through the power piston. The resulting pressure, acting upon the power piston, applies force to the master cylinder's primary piston, "boosting" the force applied to it by the driver.

The Booster assembly incorporates an electric motor/pump which provides braking boost whenever hydraulic flow ceases in the booster. A flow switch mounted at the top of the booster, next to the outlet port is held open by the normal flow of hydraulic fluid into the outlet. When pressure is absent, this switch closes, energizing a power relay, and thereby providing electrical power to the motor. The switch also causes a buzzer to sound in the driver's area and the BRAKES warning light to illuminate in the instrument panel. (See the Chassis Electrical chapter for schematic).

Troubleshooting

Symptoms which may indicate booster failure include, but are not limited to:

- Hydraulic steering fluid leakage between the master cylinder and booster.
- Hard pedal. Excessive pressure is required at the pedal to apply brakes.
- Actuated pedal does not return.
- Brake self apply May indicate self applied booster due to too high fluid flow.
- Brake drag. May indicate selfapplied booster due to too high fluid flow

For a more detailed description the booster's internal operation, as well as troubleshooting guidelines, see Hydraulic Brakes Appendix 1 (Bosch publication: HydroMax Hydraulic Brake Booster and Master Cylinder). If the booster is determined to be malfunctioning, it must be replaced. Replacements are available from your Blue Bird Parts Distributor.

Removal

As described above, the booster supports the master cylinder. Although it is possible to remove the booster without removing the master cylinder, doing so will require devising means by which to support the weight of the master cylinder so as to avoid bending the brake lines. The following procedure therefore assumes that the master cylinder/brake booster assembly will be removed as a unit, and that the two components will be separated after removal. Note that this will require that the brake system be bled after reassembly.

482

1. Park the bus on a level surface with parking brake on.
2. Disconnect the negative terminal of the battery.
3. The brake balance sensor and the booster pressure sensor lead to a single connector at the wire harness. Disconnect the connector. Disconnect the boost pump motor relay.

Caution

Do not apply the brakes after removal of the input hose unless the reserve boost system is disconnected. Reserve boost pressure will blow the inlet check valve out of the booster.

4. Loosen the hose clamp at the booster outlet, remove the hose and plug its end.
5. Remove the hose fitting at the booster inlet and plug its end, and/or support it vertically to prevent spillage.
6. Disconnect both output brake lines from the master cylinder.
7. Inside the bus, remove the cotter pin, washer and clevis pin which connect the booster push rod to the brake pedal lever.
8. Inside the bus, remove the four nuts which secure the booster's mounting studs to the driver's toe box. While doing this, have a helper support the master cylinder/booster assembly, or devise other means to support it while removing the nuts.



9. Remove the four bolts, nuts, and washers which fasten the master cylinder to the booster assembly.

Servicing

If found defective, the brake booster must be replaced. Contact your Blue Bird parts distributor for a replacement. Refer to Appendix 1 for more information.

Installation

Install the booster by reversing the removal procedure.

1. Assemble the master cylinder to the booster and tighten the four bolts to 25–30 ft. lbs. (33.9–40.7 Nm).
2. Mount the reassembled master cylinder/booster unit on the vehicle and tighten the four mounting nuts to 18–25 ft. lbs. (24.4–33.9 Nm).
3. Reattach the brake fluid lines to the master cylinder and tighten the nuts to 200 in. lbs. (22.5 Nm).
4. Inside the bus, attach the booster push rod to the brake pedal lever with the clevis pin and washer. Use a new cotter pin.
5. After installation, the brake system must be bled before operating the bus. This must be done according to procedure for the Meritor Wabco ABS system. See Appendix 2.

ABS Modulator

The ABS modulator is mounted in a bracket affixed to a frame crossmember, just above the forward end of the front most driveshaft. The modulator houses the ABS solenoid control valves (one inlet valve and one outlet valve per wheel), a pump motor, and two accumulators

Under normal braking conditions, the modulator unit receives brake fluid pressure from its two inlets (one for the front brakes; one for the rear) and distributes it evenly to the two brake calipers in each circuit. However, if a wheel starts to lock, a signal from the ECU cause a solenoid control valve to regulate the brake pressure to that wheel. During such an ABS stop, the solenoid valve is rapidly pulsed; opening and closing several times per second to control the brake pressure and prevent wheel lock. When this occurs, the driver may notice a pulsation of the brake pedal.

Troubleshooting

For troubleshooting and diagnosis of the modulator, see Appendix 2. The modulator should be replaced as a unit if found to be defective.

Removal

Removing the modulator involves three electrical plugs, six brake fluid tubes, and three mounting studs:

1. Park the bus on a level surface with parking brake on.
2. Disconnect the negative terminal of the battery.
3. Disconnect the chassis wire harness's control plug and main ground plug from the modulator unit. Disconnect the pump's pigtail component from the chassis wire harness.
4. Mark the six brake lines for ease of installation. Place a container under the modulator assembly to catch leaking brake fluid. Disconnect the six brake lines.
5. The mounting holes of the bracket are slotted and open on the top. Loosen the mounting nuts on the modulator's three rubber isolator mounts and lift the modulator out.

Reinstallation

Reinstall the modulator in the reverse order of removal, being sure to tighten fittings to the appropriate torque values:

1. Place the modulator in its bracket, being sure the studs of the three rubber isolators seat in the bottom of the mounting slots. Tighten the mounting stud nuts to 132 in. lbs (15 Nm).
2. Connect the main ground plug and the control plug on the chassis wire harness to the unit. Connect the pump's pigtail connector into the wire harness.
3. Connect the two small brake lines and tighten to 108 in. lbs. (12 Nm).
4. Connect the four larger brake lines and tighten to 132 in. lbs. (15 Nm.).
5. After installation, the brake system must be bled before operating the bus. This must be done according to procedure for the Meritor Wabco ABS system. See Brakes Appendix 2 (Meritor Hydraulic ABS Maintenance Manual no. 39) for brake bleeding procedure.

Wheel Speed Sensors

A wheel speed sensor is mounted on the inboard side of each wheel assembly. As the wheel rotates, the flats of a notched casting in the wheel end assembly pass in close



proximity to the sensor. The sensor responds to the passing notches magnetically and outputs a voltage, which increases with the speed of the wheel. This signal is then used by the ECU to determine when wheel lock is imminent.

Troubleshooting

Appendix 2 includes specific information on testing the output voltage and resistance of the wheel speed sensors. Sensors found out of range should be replaced.

Removal

The sensors are held in place by the friction fit of spring clip sleeves which are inserted into the mounting blocks with the sensors. To remove a sensor:

1. Apply the parking brake. Chock the tires to prevent vehicle movement.
2. Disconnect the sensor cable from the wire harness and remove the cable from any cable clamps or clips.
3. Pull the sensor straight out of its socket, using a twisting motion if required. Do not pull on the wires. On front wheels, removal of the sensor may be impeded by interference with the steering arm casting. If this occurs, removal may be more easily achieved by removing the two bolts which secure the sensor's mounting block.
4. The spring clip may remain in the socket, or may pull out with the sensor. Remove and inspect the spring clip. Replace any damaged spring clips with new ones.

Installation

The steps below assume the sensor has been removed without removing its mounting block. If removal of the sensor has required removal of its mounting block, install the new sensor into the mounting block according to the steps below and reinstall the mounting block using a thread locking compound on the threads of the two bolts and tighten the two mounting bolts to 16–18 ft. lbs. (21.7–24.4 Nm).

1. Connect the new sensor cable to the chassis harness.
2. Press the sensor spring clip into the socket until it stops. Make sure the tabs are on the inboard side.
3. Apply an appropriate lubricant to the shank of the sensor. Lube must be mineral oilbased and contain molydisulfide. It should have excellent anticorrosion and adhesion characteristics and be capable of continuous function in a temperature range of 40° to 300°F (40 to 150° C).

4. Push the sensor completely into the spring clip until it contacts the tooth wheel.
5. Reattach the sensor cable to the cable clamps or clips.
6. Secure the sensor cable with tie wraps every 12 inches. Properly bundle and store excess cable.

ECU (Electronic Control Unit)

The ECU is a rectangular black box mounted above the PDU on the interior side fire-wall. The unit receives signals from the wheel speed sensors, processes them, and generates solenoid valve commands for the ABS modulator to reduce, maintain or reapply brake pressure.

When the ECU senses an error in the system, it activates the ABS light on the driver's instrument panel according to a set of blink codes, which can help diagnose the system. A description of the blink codes is contained in Appendix 2

The ECU also stores ABS errors which it has detected but which are not presently active. This information can be accessed and used to troubleshoot the ABS system using Meritor Wabco's PC-based diagnostic software. The PC is connected using an appropriate adapter to the 1560 plug located in the upper right corner of the driver's toe box. Once connected, the diagnostic software can communicate with the ECU to display system faults and wheel speed data, test individual components, verify wiring, and more. The specific interface adapter needed will vary according to the specific PC setup being used. Meritor Wabco provides a tollfree number, 800/535-5560, for ordering the software and for assistance.



Removal

The ECU is mounted by three bolts, nuts, and lock washers inside the right wall of the driver's transmission control housing bracket. To remove:

1. Park the bus on a level surface with parking brake on.
2. Disconnect the negative terminal of the battery.
3. Remove the four driver's control housing mounting screws.
4. Disconnect the three harness wiring plugs from the bottom side of the unit.
5. Unbolt the ECU from the Driver's control housing support bracket.

Installation

Reinstall the ECU in reverse order of the removal steps.



Calipers

The Blue Bird Vision with hydraulic brakes uses Meritor 70mm fourpiston Quadraulic disc brake calipers. The same model caliper is used on all four wheels, but left and right side housings are mirror versions. An installation includes four major components: the caliper itself, the caliper support assembly, hub/rotor assembly, and attaching hardware.

When brakes are applied, brake fluid pressure (as regulated by the ABS modulator) causes the caliper's pistons to extend, pressing the brake friction pads against the surfaces of the rotor. The brake fluid line from the modulator attaches directly to the inboard side of the caliper. A crossover tube supplies fluid to the outboard pistons.

Servicing

If a caliper assembly is leaking, has stuck piston(s), or is otherwise found damaged, it must be replaced or rebuilt according to manufacturer's instructions. Stepby step procedures for rebuilding the brake calipers are included in Appendix 3.

WARNING *Do not rebuild a caliper with damaged piston bore(s). If the piston bore is corroded, galled or scratched, replace the caliper assembly. Replacing only the piston and seals will not correct the damage. Do not attempt to hone or rebore damaged piston bores. Piston sized for honed caliper bores are not available.*

Removal

The caliper housing is mounted to the caliper support assembly by four bolts on the inboard side of the caliper.

1. Park the bus on a level surface with parking brake on. Block the wheels to prevent the vehicle from moving.
2. Raise the wheel to be serviced and support the vehicle with safety stands.
3. Remove the tire and wheel assembly.
4. Remove the brake hose from the inboard side of the caliper.
5. Remove the four calipertosupport assembly bolts.

Installation

To install the caliper, reverse the removal process. Torque the caliper mounting bolts to 320–360 ft lb (434–488 Nm). Bleed the affected brake lines system and road test the vehicle before returning it to normal service.

Brake Pads

The brake pads on the front and rear of the Vision, and on the inside and outside of the calipers are identical (8 total). Whenever working on the brake system, avoid contamination of the brake pads by brake fluid or grease. Contaminated brake pads, even if new, must be replaced.

Inspection

Brake pads should be inspected for amount of wear at least every 3000 miles. When the friction pad material is worn to a thickness of 1/8 inch (3.2mm), the pads must be replaced. It is recommended that when one brake pad has reached its service limit, all brake pads should be replaced. If not, at least the brake pads on both sides of the same axle must be replaced at the same time.

Removal

Removal of the brake pads requires removal of the wheel, but not of the caliper. The brake pads are held in place by retainer spring plates, which are secured with one bolt.

1. Park the bus on a level surface with parking brake on. Block the wheels to prevent the vehicle from moving.
2. Raise the wheel to be serviced and support the vehicle with safety stands.
3. Remove the tire and wheel assembly.
4. Remove the master cylinder reservoir filler cap. Check the brake fluid level in the reservoir. If necessary, remove fluid to keep the reservoir from overflowing when the caliper pistons are compressed.
5. Remove the pad retainer spring bolt and remove the retainer spring.
6. Remove the two brake pads.

Installation

Because the pistons travel out from their bore during the wear of the pads, it is necessary to compress them back into their bores sufficiently to accommodate the thickness of the new pads.

1. Compress the caliper pistons. This can be done with a thin plate and cclamps as shown. Compress the two pistons slowly and equally so as to avoid cocking or wedging either piston in its bore.
2. When the pistons have been retracted enough to accommodate the new pad, insert the new pad. Be sure that the friction side is against the rotor.



3. Insert the tab of the retainer spring into its retaining hole on the outboard side of the caliper. Install the retainer spring bolt and tighten to 30 ft. lbs. (40 Nm).

Brake Rotors

Disc brake rotors are subject to temperature and stress extremes. As brake pads wear during normal operation, grooves or ridges may develop in the rotor surfaces as a result of road contaminants. The service life of the rotor surfaces may or may not correspond to that of the pads, depending upon operating conditions.

The front axle on the Blue Bird Vision with standard hydraulic brakes is a Hendrickson 60952 axle with Meritor brake components. The rear axle is a Meritor RS 21145NFB1012 with Meritor brake components. Removal procedures differ accordingly.

Inspection

Whenever replacing brake pads, inspect the rotors for scoring, warping, cracks, bluing, heat spots or other damage, and for minimum thickness. Repair or replace if necessary. Rotors may be resurfaced at an appropriate truck brake service shop. The thickness of the resurfaced rotor must always exceed the minimum thickness dimension stamped or cast into the rotor. Replace if necessary.

Check the rotor while it is assembled to the hub and mounted on the axle. The lateral runout of the rotor friction surfaces should not exceed .015 in. (.381 mm) total indicator reading (TIR). The thickness variation of the rotor should not exceed .0012 in. (.03 mm). If the lateral runout and/or the thickness variation exceed these values have the rotor resurfaced.

Removal, Front

Remove the front rotor as follows:

1. Park the bus on a level surface with parking brake on. Block the wheels to prevent the vehicle from moving.
2. Raise the wheel to be serviced and support the vehicle with safety stands.
3. Remove the tire and wheel assembly.
4. Remove the brake caliper assembly as described in the Calipers section.
5. Remove the ABS sensor.
5. Remove the drain plug from the oil lube hubcap. Drain the oil
5. Remove the six bolts which fasten the hubcap. Remove the hubcap and its gasket.

6. Flatten the tab of the bendable lock washer to allow removal of the wheel nut. Remove wheel nut and bendable lock washer.
7. Remove the pierced lock ring.
8. Remove the adjusting nut.
7. Remove the outer tapered cage bearing.
8. Slide the hub/rotor assembly off the axle. Note that the inner bearing and seal will slide off together with the hub. Take care to maintain alignment so as to avoid damaging the seal.

Installation, Front

Reinstall the front rotor by reversing the removal procedure:

1. Slide the hub/rotor assembly onto the axle. Take care to maintain alignment so as to avoid damaging the inner seal.
2. Pre-lube the outer wheel bearing and install.
3. Install adjusting nut with locking tab outboard. Torque to 100 ft lb (135.5 Nm). Back off nut. Torque to 20 ft lb (27 Nm). Then back nut off 1/3 turn. After proper adjustment, verify hub rotation.
4. Install pierced lock ring, verifying the engagement of the locking tab to the adjusting nut. Tighten nut if necessary for lock alignment.
5. Install a new bendable lock washer.
6. Install wheel nut and torque to 200–300 ft lb (271–407 Nm). Verify hub rotation.
7. Check bearing adjustment with a dial indicator and magnetic base. Bearing end play should not exceed .005 in. (.127 mm).
8. Install hub cap and gasket. Use a new gasket if the original was damaged during removal.
9. Reinstall caliper assembly. Torque mounting bolts to 320–360 ft lb (434–488 Nm).
10. Fill hubcap with appropriate oil for the buses climate. See
11. Install ABS sensor.

Removal/Installation, Rear

To remove the rear disc rotor:

1. Park the bus on a level surface with parking brake on. Block the wheels to prevent the vehicle from moving.
2. Raise the wheel to be serviced and support the vehicle with safety stands under the frame rails.
3. Remove the tire and wheel assembly.
4. Remove the brake caliper assembly as described in the Calipers section, above.
5. Place a drain pan under the end of the axle to catch brake axle lubricant.
6. Remove the 8 axle nuts and 8 star lock washers.

491

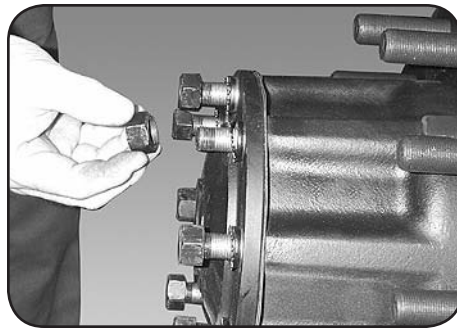

7. The axle end cap is centered by conical dowels on each of the 8 studs. It may be necessary to loosen the dowels, to allow removal. Hold a 1 1/2" diameter

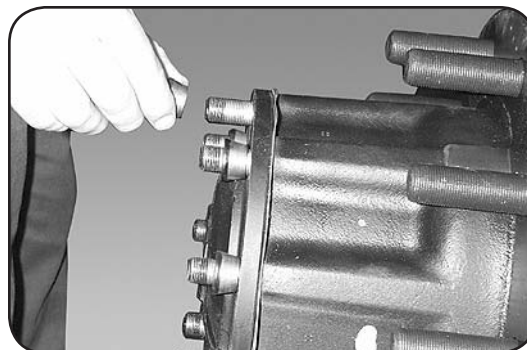
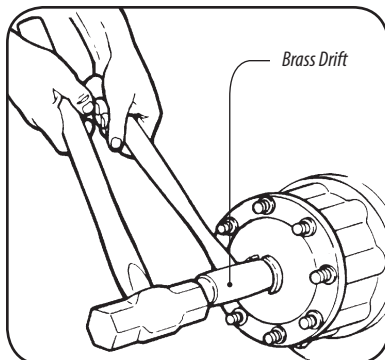

brass drift against the center of the axle end cap, inside the round driving lugs. Then strike the end of the drift with a large hammer (56 lbs.). Remove the loosened dowels.

8. Remove the axle shaft and gasket.

9. Inside the rotor hub, the outer 4" adjusting nut is held in place by a tabbed retainer washer. Using a small hammer and punch, straighten the bent tabs of the lock washer.

10. Remove the outer 4" adjusting nut, the tabbed washer, and the wheel bearing lock washer.

11. Remove the 4" adjusting nut and the outer wheel bearing.

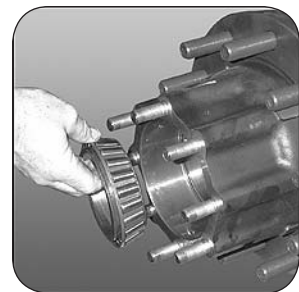
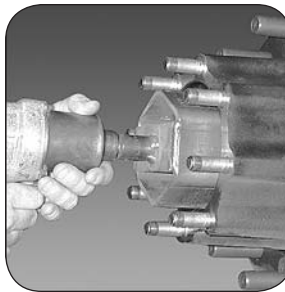
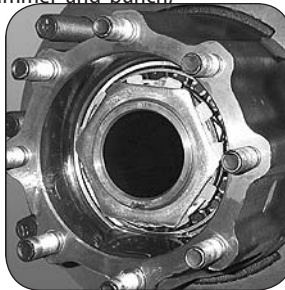
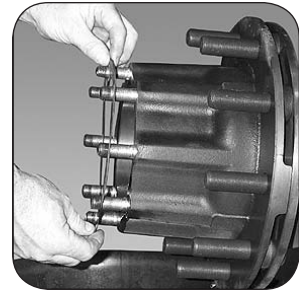
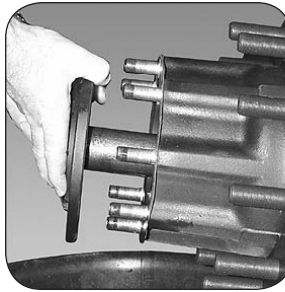

The rotor can now be removed. Remove the rotor gently and as straightly as possible to avoid damage to the inner bearing rubber seal.

Installation, Rear

Reinstall the rear rotor and adjust the wheel bearing as follows:

1. Slide the hub/rotor assembly onto the axle. Take care to maintain alignment so as to avoid damaging the inner seal.
2. Pre-lube the outer wheel bearing and install.
3. Install the 4" adjusting nut with locking pin facing outward. Torque to 100 ft lb (135.5 Nm). Back the nut off 1 turn. Torque to 50 ft lb (68 Nm). Then back nut off 1/3 turn.
4. Install the wheel bearing lock washer. If the hole in the washer is not aligned with the adjusting nut pin, remove the washer, turn it over, and reinstall. The pin should now be aligned. If not, slightly adjust the inner adjusting nut. Use whichever lock washer hole causes the least movement of the adjusting nut.

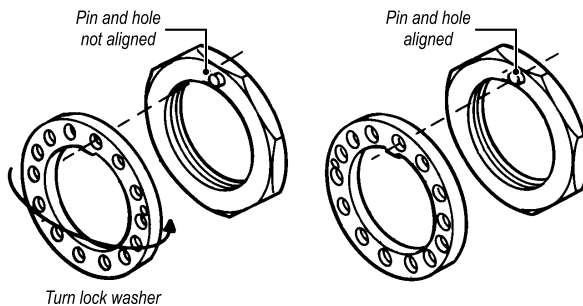
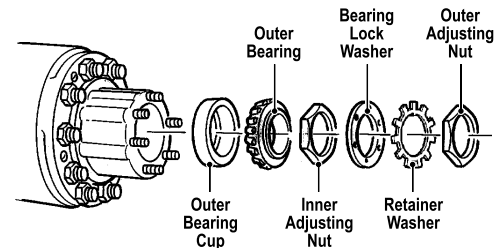
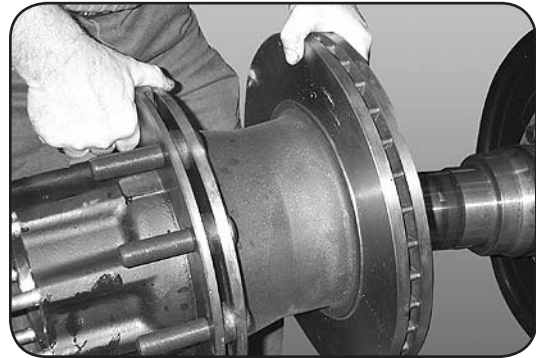

5. Install the tabbed retainer washer.
6. Install outer wheel bearing adjusting nut and torque to 100–200 ft lb (136–271 Nm). Verify hub rotation.
7. Bend two tabs of the retainer washer up against the flats of the adjusting nut.
8. Install axle shaft gasket. Use a new gasket if the original was damaged during removal.
9. Install the axle shaft.

10. Insert a tapered dowel onto each of the axle shaft studs, narrow end first. Install the eight star washers and eight nuts. Working back and forth across the center of the axle, gradually tighten the eight nuts to 150–230 ft lb (203–312 Nm).
11. Reinstall caliper assembly. Torque the four mounting bolts to 320–360 ft lb (434–488 Nm).
12. Check bearing adjustment with a dial indicator and magnetic base. Bearing end play should not exceed .010 in. (.254 mm).
13. Install wheel, and wheel mounting nuts. Draw up the wheel nuts evenly, rotating the wheel a few turns to be sure to remove all free play in the mounting nuts. Then use a calibrated torque wrench to gradually tighten the wheel nuts to 450–500 ft. lbs. (610–678 Nm), working back and forth across the center of the wheel as in the pattern shown:
14. Lower bus. Chock all wheels and check axle fluid level and replenish if necessary.

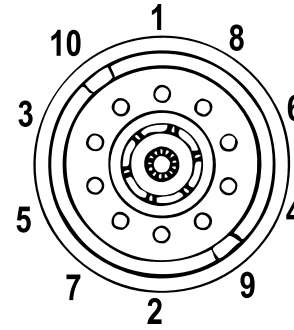



Brake Interlock, Hydraulic

As a safety feature, Blue Bird Visions equipped with wheelchair lift doors incorporate a Mico 691 brake interlock system designed to automatically apply the hydraulic service brakes when the lift door is open. The main components of the interlock system include a motor driven hydraulic pump called the power unit, an actuator which operates in principle similar to a master cylinder, and a solid-state control module. The power unit and actuator are mounted on the engine side of the firewall next to the HydroMax master cylinder/booster assembly. The control module is mounted on the driver side (bus interior) of the firewall.

The interlock system has its own separate brake fluid supply and reservoir, and uses DOT 5 fluid. The interlock system's fluid supply is not shared by the service brake system, which uses DOT3 fluid.

The interlock function is controlled by the Multiplex System. Whenever conditions required for interlock exist (see MPX Ladder Logic line # 21), the MPX Module supplies a path to ground for the interlock control module, which starts the power unit's motor. The power unit pumps hydraulic pressure to the actuator, which applies braking pressure to the service brakes master cylinder exactly as if the driver had pressed the brake pedal.

When activated, the interlock control module also provides a signal to the instrument panel master gauge (the speedometer), which in turn activates a visible driver alert in the warning light bank.

After being activated, the interlock system remains active until it is released by a press of the service brake treadle.

The Power Unit

The power unit incorporates two pressure switches, and is able to reverse flow to release locking pressure. The high pressure switch starts and stops the pump while pressurizing the system. The low pressure switch starts and stops the pump while releasing pressure from the system.

When locking pressure is reached, the high-pressure switch signals the control module to stop the pump. While the pump is stopped, locking pressure is held. If locking pressure drops, the high pressure switch signals for the power unit to turn on and restore locking pressure.

When the interlock system is deactivated, the pump reverses, releasing pressure from the actuator. When pressure reaches zero psi, a signal from the low pressure switch stops the pump.

The Actuator

The actuator communicates the hydraulic pressure of the interlock system to that of the Vision's service brake system, while keeping the two systems' fluid circuits separate. (The two fluid circuits use different types of brake fluid, which must not be allowed to contaminate each other.)

The power unit's fluid pressure acts upon one side of a piston in the actuator. The opposite end of this piston is in contact with the fluid of the service brake system. When the power unit pumps pressure against the interlock system side of the piston, the piston moves toward the end of its bore, closing the port leading to the service brake master cylinder, and applying pressure to the fluid of the service brake circuit.

When the power unit's pump reverses, the actuator piston moves in the opposite direction, relieving pressure from the service brakes fluid circuit, and opening the port leading to the service brake master cylinder.

Control Module

In addition to acting as a solid-state starter solenoid for the interlock system's power unit motor, the interlock control module also incorporates an LED array which displays the current state of the interlock system. The LEDs indicate the following:



Mico Control Module

- Motor Down** On when system is releasing pressure. Remains on for three seconds after PS2 goes off.
- Motor Up** On when system has been activated (proper signal on +Ext or -Ext), until PS1 comes on.
- +Ext** On when positive signal is present on brown harness wire and/or green user interface wire.
- PS1 (lock)** On when system is locked at full pressure. Receives ground signal from pressure switch #1 on white wire.
- Alarm** On when power unit is pressurizing the system. Controls user interface audible alarm.
- PS2** On whenever any pressure is present in the system. Receives ground signal from pressure switch #2 on violet wire.
- Ext** On when negative signal is present on gray harness wire.
- Delay Alarm** Comes on 9 seconds after activating the system if full system pressure has not been attained. Also comes on anytime the power unit runs to repressurize the system.

The input LEDs should be on when receiving their respective signal and off when not. Replace the 691 Control Module when this is not observed.

Control Module Troubleshooting

The following lists possible causes/solutions for particular observed situations:

- When the 691 System is activated, the brakes will not lock up and the power unit does not run.
 1. **No electric power.** Check the battery, fuse, and wiring connection.
 2. **High Pressure Switch is inoperative.** Activate the 691 system. If PS1 (lock) LED is on, unplug pressure switch 1. If pump runs, replace pressure switch 1 (high pressure switch), or check for a short to ground in the wiring.
 3. **The power unit or control module is inoperative.** Activate the 691 system. If the Motor Up LED is on, check for 12v DC at the power unit connector. Unplug the power unit and attach a voltmeter (+ to blue, - to green) to the connector leading to the control module. If 12v DC is present, replace the power unit. If 12v DC is not present, replace the control module.
 4. **The control module is not receiving an input signal.** Activate the 691 system. Check the +Ext and -Ext LEDs. If neither is on, check that a ground signal is present at the gray lead in the main wiring harness, or the green lead from the user interface; or that a positive signal is present on the brown wire in the main wiring harness. If not, determine the reason, and correct.

- When the 691 system is activated, the brakes will not lock up and the power unit continues to run.
 1. **The fluid level in the reservoir is low.** Deactivate the 691 system. Verify that the power unit is mounted level. Remove the reservoir breather/filler plug and fill the reservoir with proper fluid to within 1/4" of top. Reinstall breather/filler plug.
 2. **Hydraulic leak in either the 691 system or the service brake system.** Inspect all tubing and connections for leaks and tighten or replace as necessary.
 3. **The actuator is not functioning properly.** Activate the 691 system. Check the master cylinder reservoir for excessive fluid level. This condition indicates that the seals in the actuator are allowing 691 system fluid to leak into the vehicle service brake system. Replace the actuator and completely flush and refill the service brake fluid circuit.
 4. **The power unit is not properly building pressure.** Replace the power unit. (No test to troubleshoot this condition.)



- The 691 system will activate and lock up the brakes, but the power unit keeps running.
 1. **High pressure switch is inoperative.** Activate the 691 system. If PS2 LED is off, replace pressure switch 1 (high pressure switch).
- The power unit does not operate to release the brakes when the 691 system is deactivated.
 1. **No electric power.** Check the battery, fuse, and wiring connections.
 2. **Low pressure switch is inoperative.** Deactivate the 691 system. If the PS2 LED is off, replace pressure switch 2 (low pressure switch).
 3. **The power unit or control module is inoperative.** Deactivate the 691 system. If the Motor Down LED is on, check for 12v DC at power unit connector. Unplug power unit and attach a voltmeter (-to blue, + to green) to the connector leading to control module. If 12v DC is present, replace the power unit. If 12v DC is not present, replace control module.
- The brakes release, but the 691 power unit does not stop running.
 1. **Low pressure switch is inoperative.** Deactivate the 691 system. If the PS2 LED is on, replace pressure switch 2 (low pressure switch).
 2. **The control module is inoperative.** Deactivate the 691 system. If Motor Down LED is off, replace the control module.
- The 691 system and Motor Up LED come on unexpectedly without being activated.
 1. **The control module is receiving false signals.** Be sure stray signals are not being introduced into the external inputs. If the gray wire is not connected to an external input, ensure that it is capped off and not shorting to ground inadvertently. While deactivated, occasional operation of power unit and Motor Down LED is normal to relieve pressure caused by thermal expansion of fluid in the power unit.
- While the 691 system is activated, the power unit and horn activate intermittently.
 1. **Change in temperature has caused the system to contract and reduce brake system pressure.** The power unit runs briefly to restore brake system pressure to the original lock up pressure. This is considered normal operation as fluid temperature changes.
 2. **The service brake system or 691 system has air in it.** Bleed service brake and 691 system.

3. **Hydraulic leak in either the 691 system or service brake system.**
Inspect all tubing and connectors for leaks and tighten or replace as necessary.
4. **The power unit is not functioning properly.** Replace the power unit.
(No test to troubleshoot this condition.)

Bleeding Procedure

Because the interlock system has its own fluid circuit separate from that of the service brakes, the interlock system must also be bled separately.

1. Make sure the vehicle master cylinder reservoir (not the interlock reservoir) is filled with DOT 3 brake fluid, and that the service brake system has been properly bled.
2. Activate the interlock system.
3. Open the bleeder valve on top of the power unit a quarter turn. Close the bleeder screw when a steady stream of fluid is present.



Parking Brake

The parking brake is a dual shoe drum type brake, similar in configuration and operating principle to a normal drum brake on a passenger car. However, rather than being mounted at the wheel(s), the single drum unit is mounted on, and rotates with, a yoke on the forward end of the driveshaft. The brake shoe assembly is mounted to the rear housing of the transmission.

When the driver pulls upward on the parking brake lever, the inner cable of a conventional control cable assembly is pulled. This actuates a pivoting bellcrank linkage mounted at the opposite end of the cable, on the top of the transmission. The linkage rotates a cam situated between the two brake shoes, spreading them to force their friction linings against the drum, thereby preventing the drive shaft from turning when the bus is parked.

Adjustment

The parking brake should be adjusted so as to require between 90 and 100 pound of force at the parking brake handle just prior to breaking over center and latching in the applied position. Three cable adjustment locations are provided: On the right side of the transmission housing, the outer cable is clamped to a bracket, which has three sets of mounting holes. Any of the three sets of holes can be used to achieve the proper working range for the finer adjustments.

The clevis at the transmission end of the cable is threaded onto the swaged fitting of the inner cable. The effective cable play can be adjusted by:

1. Loosen the clevis lock nut.
2. Disconnect the clevis by removing its cotter pin and clevis pin.
3. Turn the clevis to adjust the cable length. Be sure to always leave at least a few threads of the cable end fitting showing inside the clevis.
4. Reattach the clevis using a new cotter pin and tighten the lock nut.

The cable length can also be adjusted at the parking brake handle:

1. Remove the setscrew in the knurled end of the handle.
2. Rotate the knurled handle to adjust the tightness of the cable.
3. Replace the setscrew and tighten.

Inspection

Parking brake service life will be dependent upon operating conditions and usage. Being designed for normal use with the bus stopped and parked, the drum and shoes of the parking brake are smaller and thinner units than would be used in drum type service brakes. Under normal usage brake lining wear should be minimal. How-

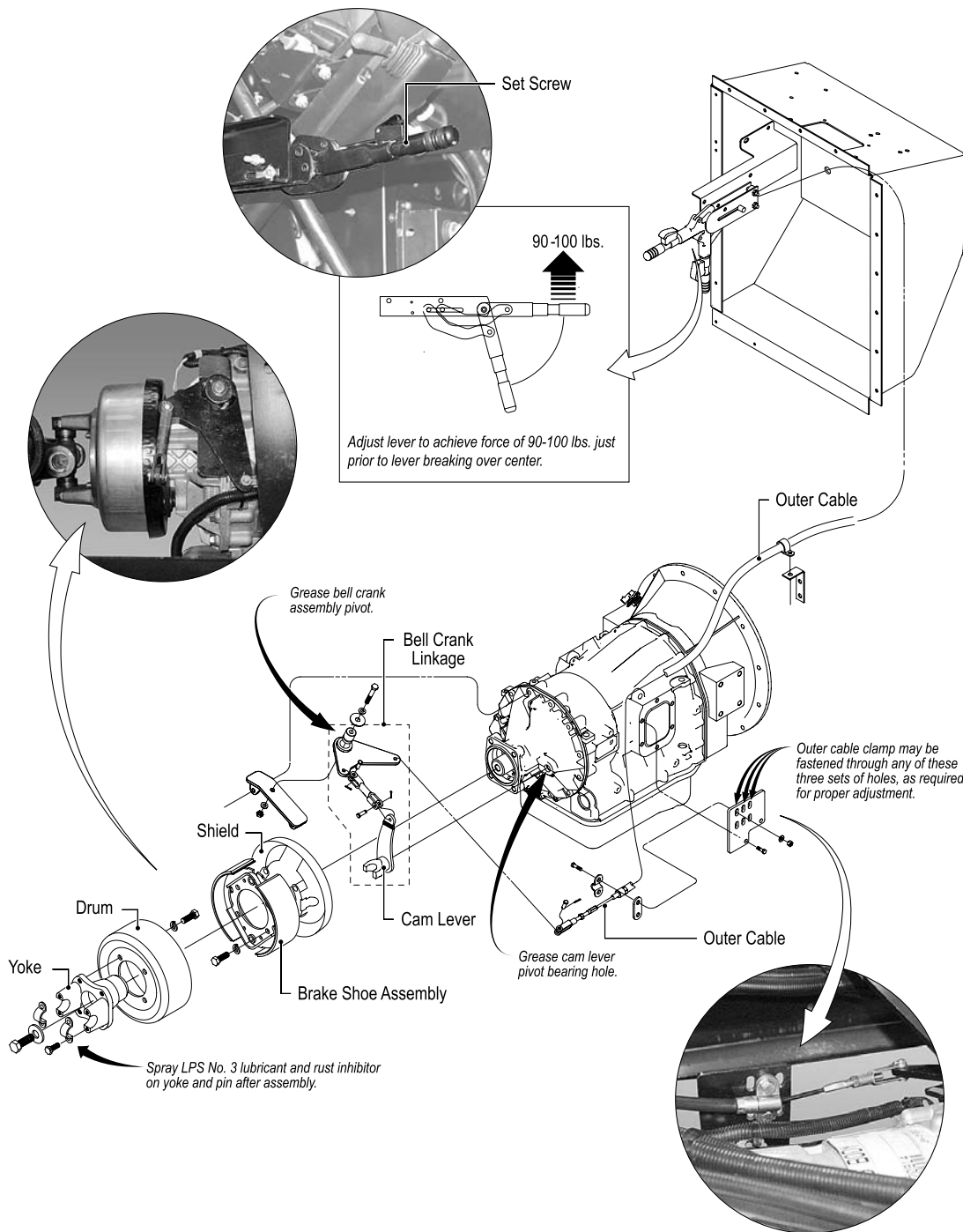

Park Brake (on units with hydraulic brakes)



ever, the entire parking brake assembly should be disassembled and inspected after any use of it in an emergency stop situation.

Lubrication

A grease fitting is located on the bell crank pivot bushing. Grease should also be applied to the bearing hole on the transmission housing in which the knob of the cam lever pivots.

Removal & Disassembly

To remove the parking brake so as to inspect its brake shoes, drum and other components:

1. Park the bus on a level. Securely block the wheels to prevent the vehicle from moving in either direction.
2. Loosen, but do not remove, the bearing hanger bolts forward of the driveshaft slip joint. This is to allow some axial movement of the driveshaft when unbolting the front shaft from the transmission yoke.
3. Remove the two yoke clamps securing the front driveshaft pivot pin to the yoke.
4. Use a pry bar to carefully push the driveshaft rearward enough to clear the yoke clamps, and carefully lower the front of the drive shaft.
5. Apply the parking brake to prevent the transmission shaft from turning when loosening the yoke mounting bolt. Remove the yoke mounting bolt. Release the parking brake and remove the yoke & drum assembly.
6. To remove the drum from the yoke, mount the yoke in a bench vise with drum facing upward, and remove the four bolts from the inside of the drum.
7. Remove the four bolts which fasten the brake shoe assembly and parking brake shield to the transmission housing. The brake shoes can now be removed from the plate by hand on a workbench.

To remove the bell crank linkage:

8. Remove the cotter pin and clevis pin at the end of the inner cable's screwon clevis.
9. Remove the bell crank pivot bolt. The bell crank linkage can now be removed as an assembly.

Installation

1. Grease the socket hole on the transmission housing in which the cam lever pivots. Insert the pivot ball of the cam lever into the hole. Insert the pivot bolt through the bushing of the bell crank assembly, tightening it to 33 ft. lbs. (44.7 Nm). Connect the clevis end of the cable to the bell crank, using a new cotter pin on the clevis pin.
2. With the yoke mounted in a bench vise, assemble the drum to the yoke, tightening the four mounting bolts to 90 ft. lbs. (122 Nm).
3. Mount the parking brake shield and brake shoe assembly to the transmission housing. Check to ensure that the lugs of the cam lever properly engage the space between the ends of the brake shoes. Tighten the four mounting bolts to 90 ft. lbs. (122 Nm).
4. Slip the assembled yoke and drum onto the transmission's splined output shaft. Insert the mounting bolt and handtighten. Apply the parking brake by pushing on the bell crank linkage, to prevent turning of the transmission shaft as the yoke mounting bolt is tightened. Tighten the yoke mounting bolt to 110 ft. lbs. (150 Nm).
5. Assemble the front driveshaft to the yoke using two new yoke straps. Tighten to 45–60 ft. lbs. (6181 Nm).
6. Tighten all driveshaft bearing hanger bolts to 29–33 ft. lbs. (39–45 Nm).



Hydro-Max™ Hydraulic Brake Booster and Master Cylinder

505

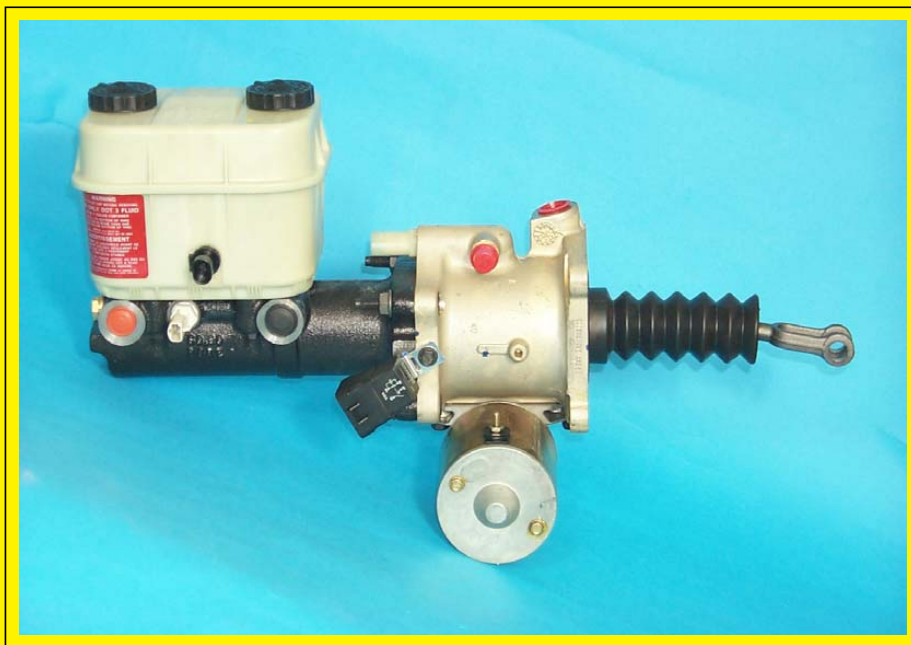

Technical Manual



BOSCH

BOSCH

506

Important Service Notes

The information in this publication was current at the time of printing. The information presented in this publication is subject to change without notice or liability.

The information contained in this publication is intended for use by properly trained and equipped professional technicians. It is NOT for the "Do It Yourselfer".

Failure to follow safety and repair procedures can result in personal injury, or damage to vehicles, components and equipment.

Correspondence concerning this manual should be addressed to:

Robert Bosch Corporation
ATTN: Hydraulic Actuation & Truck Brake Engineering
401 North Bendix Drive
South Bend, Indiana 46628

Fax: 574-237-2210

August 2003



Hydro-Max™ Technical Manual

BOSCH

Table of Contents

<i>General Description</i>	1
<i>Hydro-Max™ Booster</i>	1
<i>Master Cylinder</i>	1
<i>Principle of Operation</i>	3
<i>Hydro-Max™ Booster</i>	3
<i>Master Cylinder</i>	5
<i>Electrical Operating System</i>	7
<i>Basic Operation of Booster and Master Cylinder</i>	8
<i>Electronic Monitor Module</i>	9
<i>Application Information</i>	13
<i>Hydraulic Fluids</i>	13
<i>Brake Fluid Tubing, Hoses and Fittings</i>	13
<i>Booster Fluid Tubing, Hoses and Fittings</i>	14
<i>Booster Fluid Source</i>	15
<i>Installation Recommendations</i>	16
<i>Pedal Return Springs</i>	17
<i>Pedal Stop and Proper Spring Load</i>	18
<i>Trouble Shooting</i>	19

507

Printed in the United States of America
 © 2002 Robert Bosch Corp.
 All rights reserved.

Hydro-Max™ Technical Manual



BOSCH

General Description

The Hydro-Max™ is a hydraulically powered brake booster which provides power assist for applying hydraulic brakes. A booster combined with a master cylinder (refer to *Figure 1*) forms the hydraulic brake actuation unit. A typical assembly is shown in *Figure 1*. The booster reduces the pedal effort required to apply the brakes as compared to a non-power system.

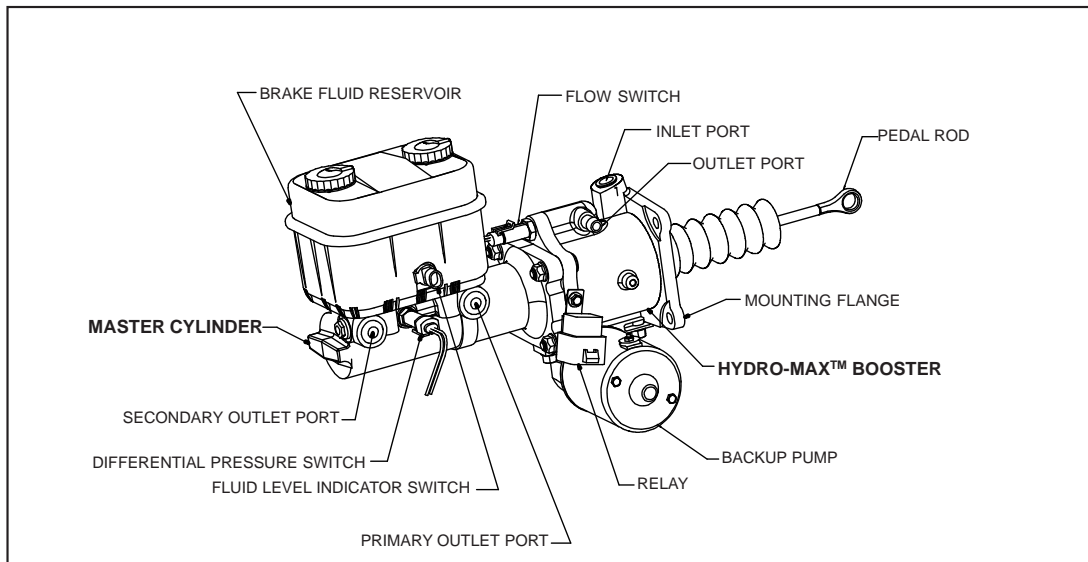

Figure 1 Hydro-Max™ Booster and Master Cylinder Assembly

Hydro-Max™ Booster

The hydraulic booster is comprised of an open center valve and reaction feedback mechanism, a power piston, a 12 and 24-volt backup pump and an integral flow switch. It is powered by either the power steering pump or other hydraulic source. The backup pump provides a secondary power source for the hydraulic booster and is controlled by the integral flow switch.

Master Cylinder

The master cylinder is a split system type with separate fluid chambers, pistons and outlet ports for the front and rear brake circuits. A differential pressure switch, fluid level indicator switch, and remote reservoir are also available.

A typical Hydro-Max™ booster and master cylinder assembly installation in a hydraulic braking system is shown in *Figure 2*.



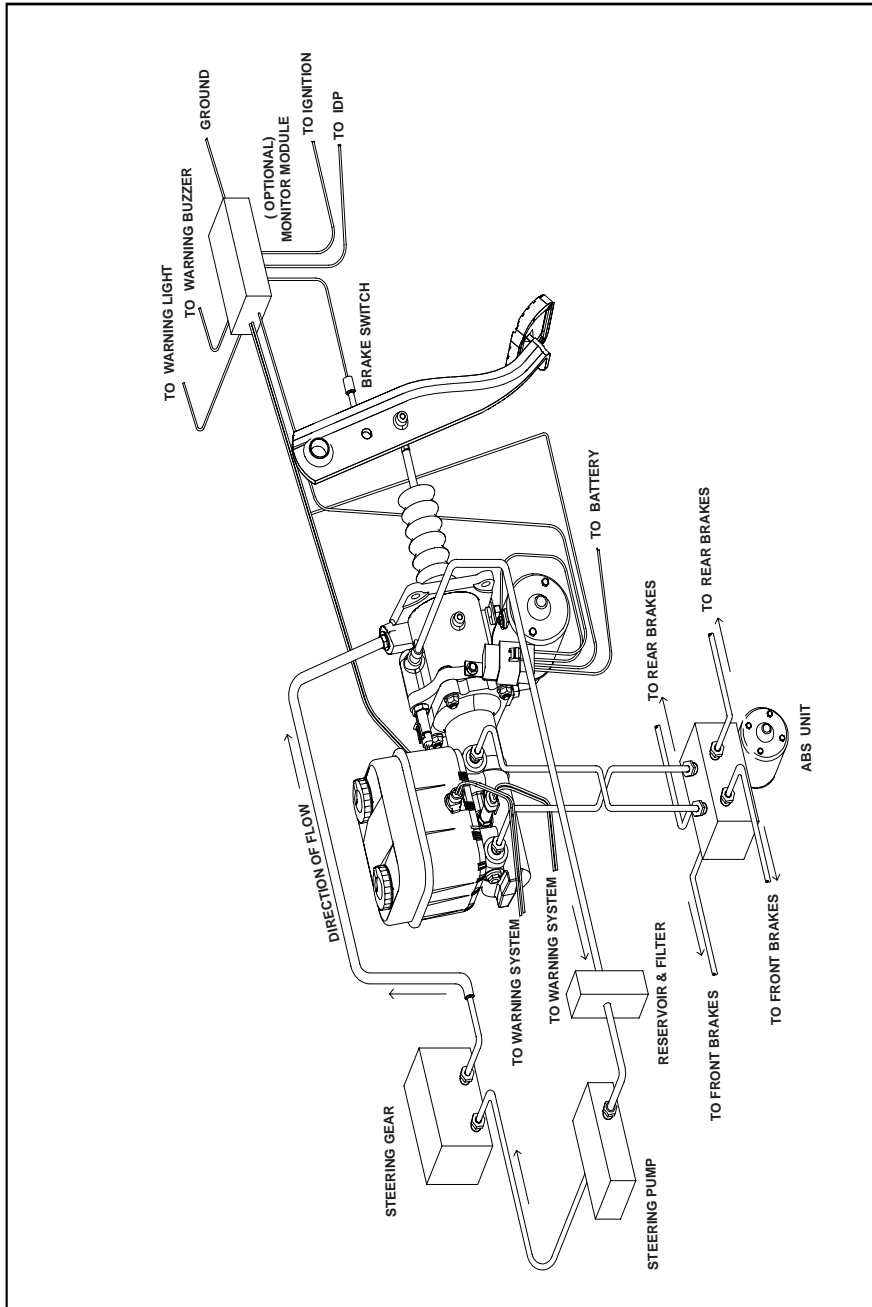

Figure 2 Typical Booster and Master Cylinder Assembly Installation in a Hydraulic Braking System





BOSCH

Principle of Operation

Hydro-Max™ Booster

During normal system operation, (refer to *Figure 4*) fluid flow from a hydraulic power source (usually the power steering pump) enters the inlet port of the Hydro-Max™ booster, flows through the power piston, around the throttle valve and through the flow switch, exiting through the outlet port.

Force applied to the brake pedal by the vehicle operator is multiplied by the lever ratio of the pedal mechanism to move the pedal rod of the booster. This movement closes the throttle valve, which restricts flow. This restriction of flow, which results in a pressure increase acting on the power piston, applies an amplified force to the master cylinder primary piston. A reaction piston, inside the power piston subassembly, provides the driver "pedal feel" during an application of the brake pedal.

Fluid flow through the flow switch opens the backup pump electrical circuit during normal operation. A separate check valve in the backup pump prevents back-flow through the pump during normal power applications.

In the event normal flow from the power source is interrupted, the backup pump provides the power at a reduced rate for stopping. See *Figure 3* for performance curve. Upon flow interruption, the integral flow switch closes, energizing a relay, providing electrical power to the backup pump.

During backup operation, the pump re-circulates fluid within the booster assembly with pressure built on demand via the throttle valve. Fluid is retained within the booster by the inlet port check valve.

Figure 3 illustrates the typical relationship of master cylinder pressure and input force of the booster.

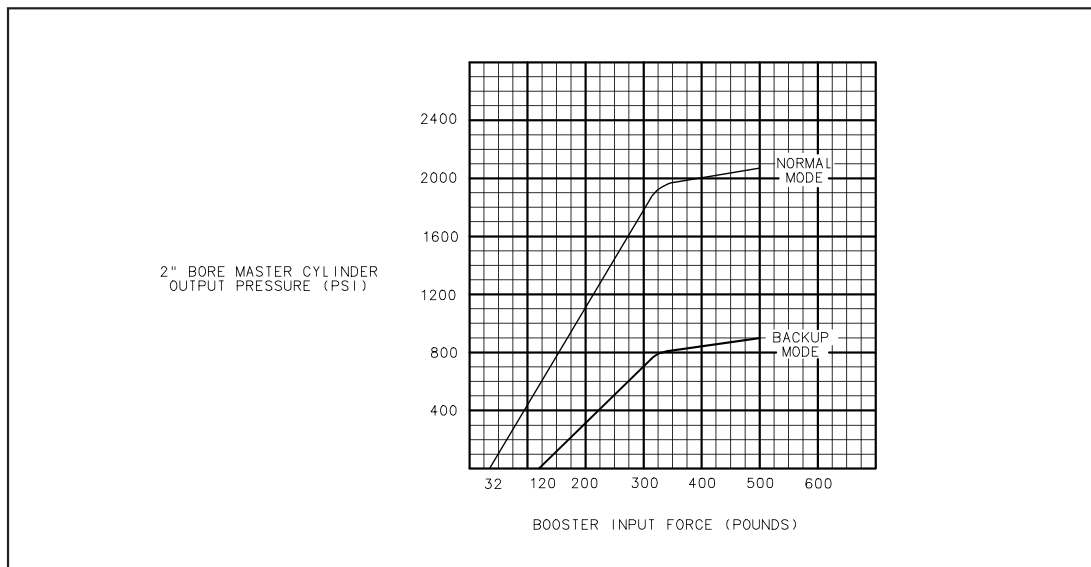

Figure 3 Typical Performance Curve



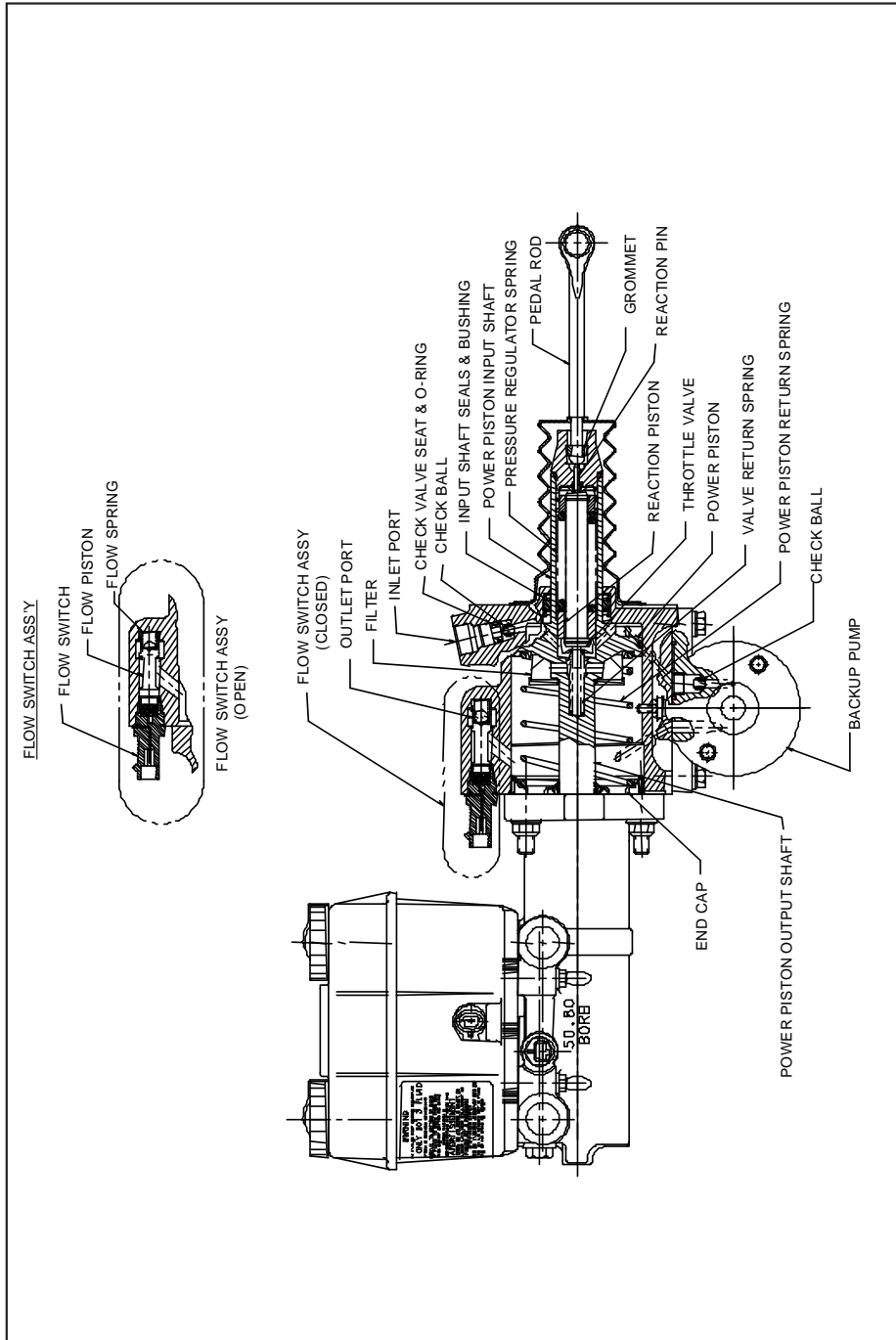

Figure 4 Hydro-Max™ Booster and Master Cylinder



**BOSCH**

Master Cylinder

In the released position, (refer to *Figure 5*) actuators of both the primary and secondary pistons are in with their respective compensating valve stems, which project into the cylinder bore. This contact tilts the valves to an open position, which allows hydraulic fluid in the reservoir sections to communicate with the primary and secondary pressure chambers. Each pressure chamber has a piston/actuator subassembly containing a preloaded (caged) spring and return spring.

Initial forward travel of the primary piston moves the primary actuator away from its compensating valve, permitting the valve to seat. Closure of this valve shuts off the passage between the primary pressure chamber and the reservoir section serving the primary chamber.

Further movement of the primary piston creates pressure in the primary pressure chamber, causing the secondary piston and actuator to move. As the secondary piston and actuator move, the secondary compensating valve closes, shutting off the passage between the secondary pressure chamber and the reservoir section serving the secondary chamber. Additional movement of the primary piston causes both chambers to build pressure.

When the load on the primary piston is removed, fluid pressure in each chamber, combined with return spring force, causes the primary and secondary pistons to return to their initial released positions. Each actuator opens its respective compensating valve, reopening the passage between the individual reservoir sections and its associated pressure chamber.

Should the rate of release be great enough to cause a partial vacuum in the chamber, the compensating valve will open to allow replenishment of fluid into the cylinder bore.

Any excess fluid remaining at the end of the stroke due to "pumping" and/or volume change due to temperature fluctuation is released to the reservoir as the compensating valves open.

The primary circuit is separated from the secondary hydraulic circuit. Hydraulic leakage in one circuit does not affect the function of the other circuit.

A fluid level indicator switch is available. It illuminates a light on the dash panel to warn of low brake fluid level in the master cylinder reservoir. A low fluid level can result from brake shoe lining wear, or it can occur if there is an external leak in the vehicle brake system.

A differential pressure switch is available. It illuminates a light on the dash panel to warn when there is a pressure differential between the primary and secondary brake circuits caused by a leak in one circuit. This may occur when one circuit leaks or is improperly bled.

A remote reservoir application is available where under-the-hood space constraints prohibit the use of a conventional booster and master cylinder assembly. In a remote application, the master cylinder reservoir is mounted separately from the master cylinder.

513

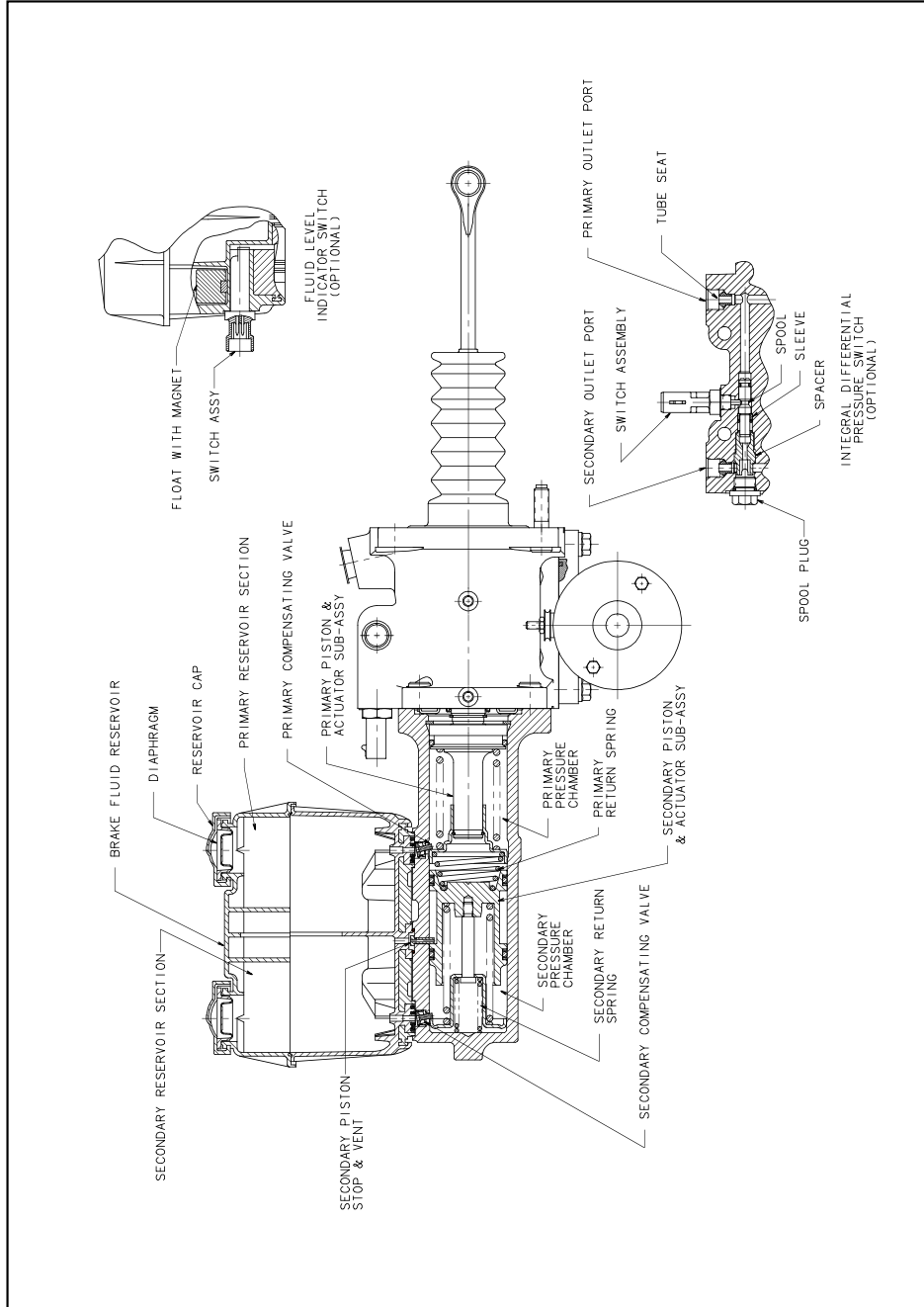

Figure 5 Master Cylinder





BOSCH

Electrical Operating Systems

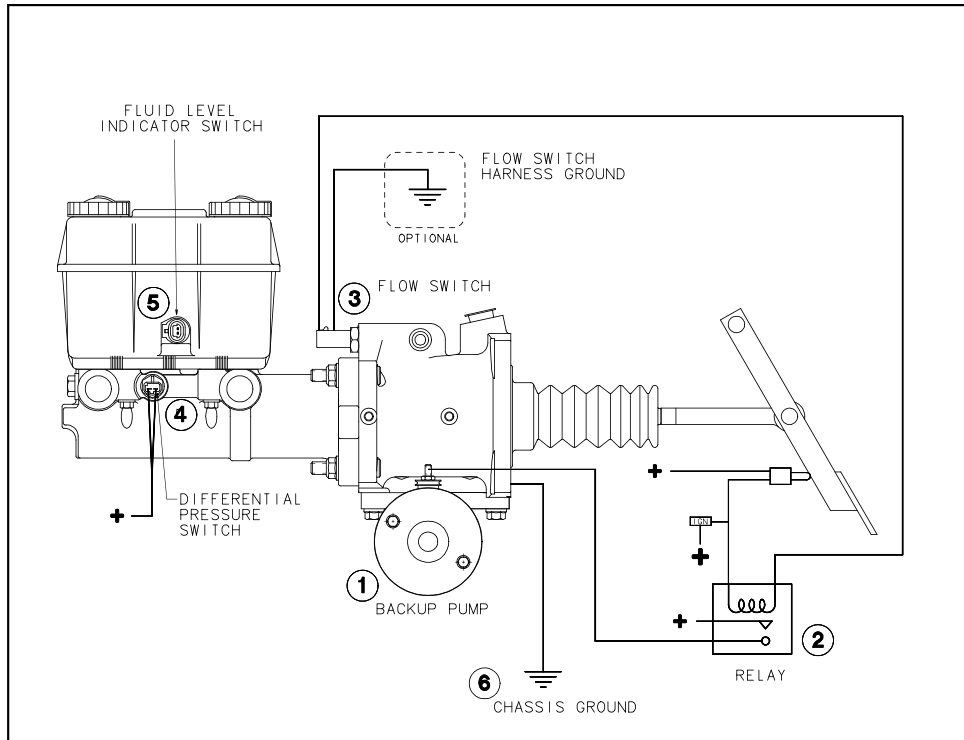

Figure 6 Schematic of Electrical Operating System

515



BOSCH

Basic Operation of Hydro-Max™ Booster Assembly and Master Cylinder

Reference *Figure 6* for the following electrical components of the booster and master cylinder.

1. **Backup Pump:** The Hydro-Max™ hydraulic booster has a backup pump which will provide hydraulic boost at a reduced rate if the normal source of fluid is interrupted (refer to *Figure 3*). The signal for operation of the backup pump comes from the flow switch. If normal flow is interrupted, the flow switch will close and activate the relay, which will turn on the backup pump. The backup pump is available for 12 and 24-volt systems.
- The 12-volt backup pump can draw a steady state maximum of 55 amps at a power steering fluid temperature of 100° F. The 24-volt backup pump can have a steady state maximum draw of 27.5 amps at 100° F.
2. **Relay:** An optional relay is available for attachment to the booster. The relay connects to a sealed and mechanically latched wiring connector. The function of the relay is to provide current to the backup pump when triggered by the flow switch.
 3. **Flow Switch:** The function of the flow switch is to activate the relay when normal hydraulic power source fluid flow is interrupted, turning on the backup pump. The flow switch has two terminals (A and B). A is positive. B is connected to the booster housing and can be used as an optional harness ground. The flow switch itself is grounded through the booster housing. A sealed and mechanically latched connector connects the flow switch to the backup pump relay circuitry.
 4. **Differential Pressure Switch:** The differential pressure switch reacts to a loss of master cylinder hydraulic pressure in either side of the split hydraulic system and can illuminate a warning light at the instrument panel. When pressure is lost in either the primary or secondary circuit of the master cylinder, the switch closes. The electrical switch will remain closed until the malfunction is corrected. When both systems develop normal pressure, the switch will return to center and open the electrical switch circuit. A mechanically latched connector is attached to the switch. The switch has two tabs on a common terminal (positive) and is grounded through the master cylinder.
 5. **Fluid Level Switch:** When the fluid reaches a predetermined level (low fluid level), the switch closes and can illuminate a warning light at the instrument panel. A sealed and mechanically latched connector is attached. The switch has two terminals, positive and negative, which are interchangeable.
 6. **Chassis Ground:** The booster and master cylinder assembly must be provided with a ground path that will carry the maximum current of the backup pump.

516





BOSCH

Electronic Monitor Modules (12-volt only)

Bosch recommends that a monitor module be included to monitor the electrical integrity of the backup system. Bosch offers two types with the following features and functions:

Monitor Module Type I

Features

1. Performs start-up self test for proper electrical signal to reserve backup pump.
2. Continuously test for an open circuit in backup pump.
3. Turns on vehicle warning light and buzzer if any of the above tests indicate a backup system electrical malfunction. The warnings are continuous until the malfunction is corrected or the power is shut off.
4. Conveys signal to provide electrical power to the backup pump via the relay.
5. Provides a centralized housing for diodes.
6. Includes an integral differential pressure switch light check at start up.

517

Figure 7 Schematic of Electronic Monitor Module Type I



BOSCH

Pin Functions

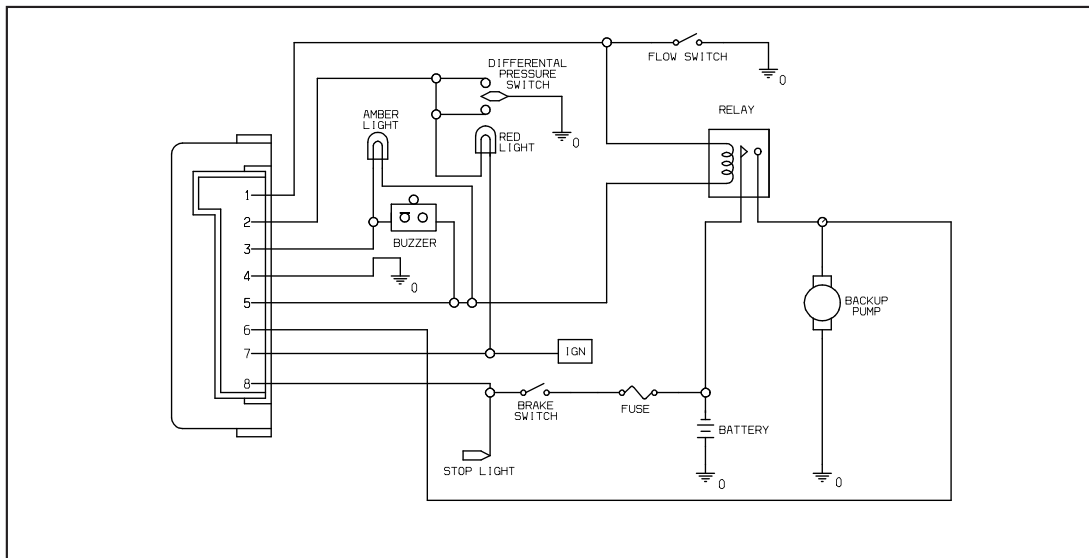
Pin	Function
-----	----------

- | | |
|--|---|
| 1 | <ul style="list-style-type: none"> a) Provides path to flow switch to ground for pin 2 to allow test of red light during vehicle start up. b) Suppresses negative voltage transients into pin 5 from the relay coil. |
| 2 | Provides path to pin 1 to flow switch to vehicle ground to allow test of red light during vehicle start up. |
| <p><u>Note:</u> Pin 1 and 2 are connected, with a diode in-between. With the key in the "on" position, the red dash panel light should illuminate anytime hydraulic flow (from the fluid power source) drops to a range of 0.5 to 1.1 gpm. (The range at which flow switch continuity occurs).</p> | |
| 3 | Open circuit when all is okay, but switches to ground (pin 4) during vehicle start or during a detected fault. Connection to ground turns on warning light and buzzer. |
| 4 | Connects monitor module to vehicle ground. |
| 5 | Supplies power from module to amber light, buzzer and relay coil. Current flow through this terminal must be limited to 300 mA. |
| 6 | <ul style="list-style-type: none"> a) Monitors for voltage to backup pump during startup. If none detected, pin 3 remains grounded (connected to pin 4). b) Monitors for continuity through the backup pump to vehicle ground during vehicle operation (engine on). Pin 3 switches to ground (pin 4) if continuity is lost. |
| 7 | Brings power into module from ignition switch. |
| 8 | Brings power into module from brake switch. Only needed when ignition switch is off. Enables backup pump to operate when ignition is off. |





BOSCH

Monitor Module Type II (12 volt only)

Features

1. Performs start-up self test for proper electrical signal to backup pump.
2. Continuously tests for an open circuit in backup pump.
3. Tests for voltage during brake application in brake light circuit and backup pump relay coil circuit on vehicles equipped with dual brake switches.
4. Turns on warning light(s) and buzzer if any of the above tests indicate a backup pump system electrical malfunction. The warnings are continuous until the malfunction is corrected or the power is shut off.
5. Absence or malfunction of the module will not affect backup system operation.
6. Turns on light(s) and buzzer when integral differential pressure switch is activated.

519

Figure 8 Schematic of Electronic Monitor Module Type II



BOSCH

Pin Functions

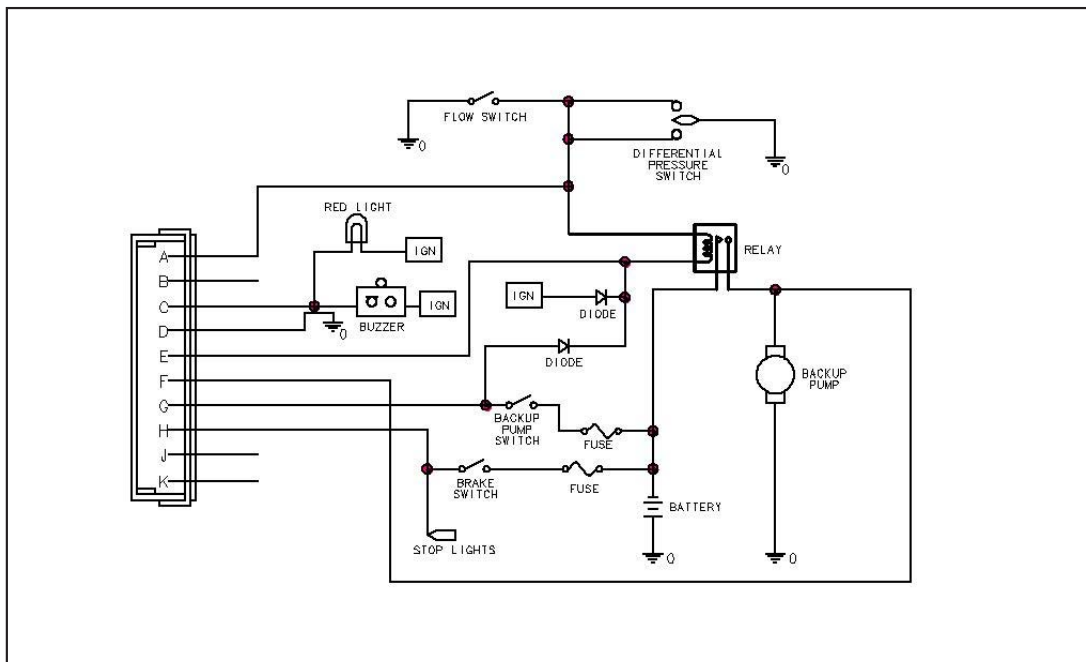
Pin Function

- A Suppresses negative voltage transients into pin E from the relay coil.
- B Not used.
- C Open circuit when all is okay, but switches to ground (pin D) during vehicle startup or during a detected fault. Connection to ground switches on warning light and buzzer.
- D Connects monitor module to vehicle ground.
- E Power input to monitor module from ignition switch or Hydro-Max™ brake pedal switch.
- F 1) Monitors for voltage to backup pump during vehicle startup. If none detected, pin C remains grounded (connected to pin D).
 2) Monitors for continuity through backup pump to vehicle ground during vehicle operation (engine on). Pin C switches to ground (pin D) if continuity is lost.
- G Monitors output of the backup pump switch that turns on the backup pump, to allow comparison with pin H. If different for > 14±5 seconds, then pin C switches to ground (pin D) and latches.
- H Monitors output of stop light switch to allow comparison with pin G. If different for > 14±5 seconds, then pin C switches to ground (pin D) and latches.
- J Not used.
- K Not used.



**BOSCH**

Application Information

Hydraulic Fluids

The Hydro-Max™ booster uses power steering fluid as the medium of transmitting power.

The master cylinder uses DOT 3 brake fluid per SAE J1703, unless otherwise specified on the top of the reservoir. Service maintenance of motor vehicle brake fluid in motor vehicle brake actuating systems is covered in SAE J1707 information report.

521

⚠ CAUTION

Before using any other type of fluid in the booster or in the master cylinder, contact the Bosch Hydraulic Actuation and Truck Brake Engineering Department. (See inside of front cover).

⚠ CAUTION

The booster and the master cylinder use two (2) distinctly different incompatible hydraulic fluids. They must not be mixed. Using the incorrect fluid will permanently damage the seals and can cause the brakes to malfunction.

Brake Fluid Tubing, Hoses and Fittings

Brake fluid lines (tubing and flexible hose) transmit fluid under pressure between the master cylinder and the brakes. The hoses are the flexible links between wheels or axles and the frame or body. The hoses must withstand fluid pressure with minimal expansion and must be free to flex without damage during normal suspension deflection and wheel turns. The following SAE specifications, or their successors if appropriate, are recommended for consideration as a minimum requirement when outfitting a vehicle with brake fluid tubing, hoses and fittings. The hoses should conform to SAE J1401 Hydraulic Brake Hose - Automotive. The tubing should conform to SAE J1047 Tubing - Motor Vehicle Hydraulic Brake System. The fittings should conform to SAE J516a - Hydraulic Hose Fittings, or SAE J512 - Automotive Tube Fittings. Contact the vehicle manufacturer for specific requirements for individual applications.



BOSCH

Booster Fluid Tubing, Hoses and Fittings

The pressure line that supplies fluid to the booster must be a 1/2" diameter flexible or rigid pressure line conforming to SAE J188 and typically designed to run from the steering gear to the Hydro-Max™ inlet. The Hydro-Max™ inlet port utilizes a tube "O" arrangement as shown in *Figure 9* (not supplied by Bosch). For tube flare configuration see *Figure 10*.

522

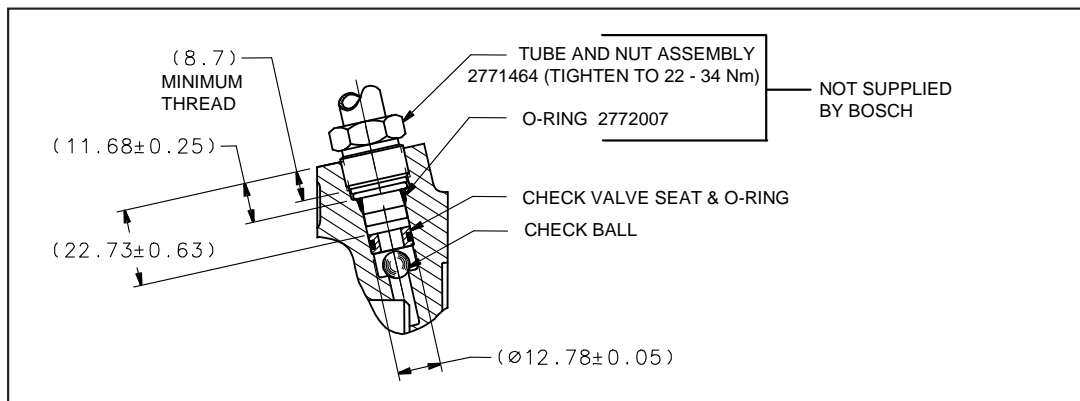

Figure 9 Tube "O" Fitting and O-ring Seal

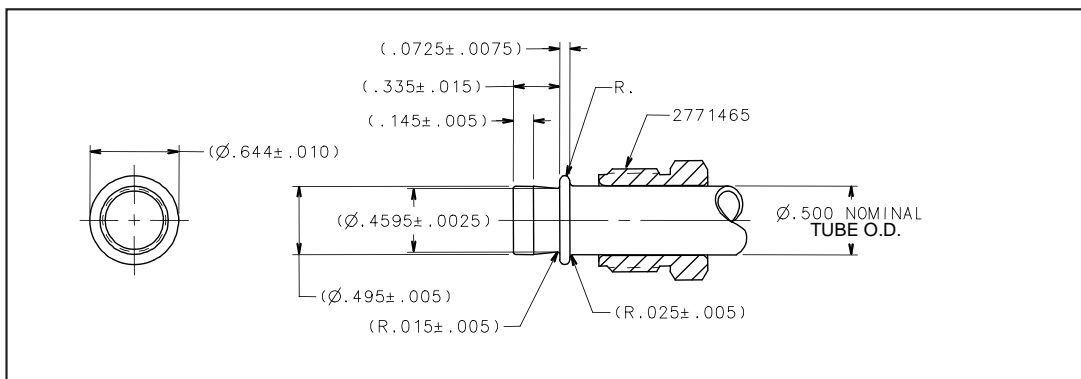

Figure 10 Tube Flare Configuration

The return line must be a 1/2" diameter hydraulic hose attached to the Hydro-Max™ outlet port (See *Figure 11*). The return line and clamp must be selected so that it will withstand worst case vehicle operating conditions, such as back pressures resulting from start up at extremely cold temperatures or from devices installed down stream of the booster.





BOSCH

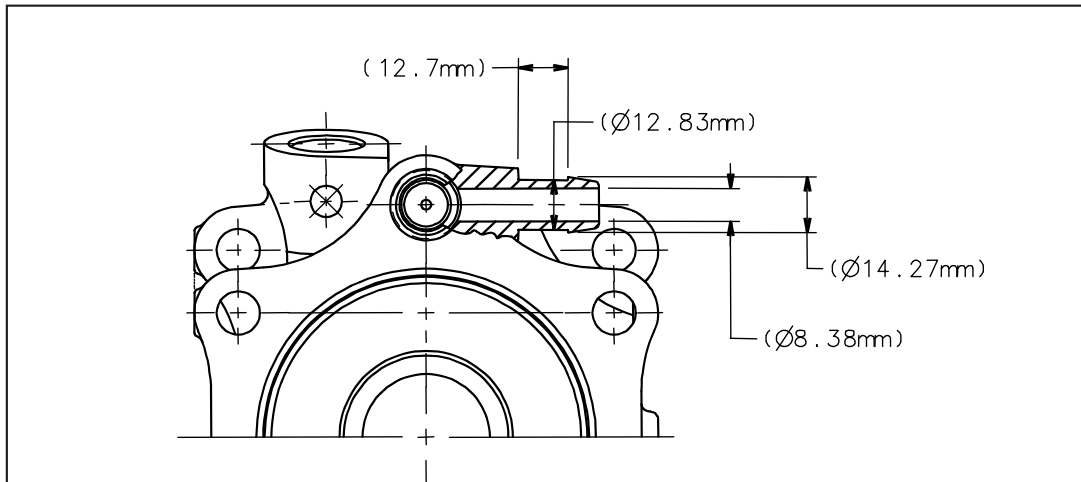

Figure 11 Outlet Port

523

Booster Fluid Source

The booster is designed to perform in a flow range of 3.2 to 5.0 gpm. Flow rate through the booster can impact vehicle stopping distance; therefore, the vehicle manufacturer must determine the required minimum flow rate. Flow rates below 3.2 gpm can cause slower response times when the booster is applied. Flow rates higher than 5.0 gpm may contribute to the booster self-applying, which will cause brake drag or fluid overheating.

The fluid power source must be capable of supplying 1,000 psi to the booster plus any additional pressure required by other devices in the system such as a power steering gear.

If a power steering gear is used, the steering gear must be "balanced" so that it can handle the pressures generated in the steering gear return line. It must also have an internal relief valve setting lower than the pump relief to allow the steering gear to relieve before the hydraulic pump does. It must also have an internal by-pass to allow manual steering during booster backup system operation. The manufacturer must adhere to the flow path illustrated in *Figure 2*.



BOSCH

Installation Recommendations

The Hydro-Max™ booster is generally mounted to a vehicle's dash panel. If necessary, the Hydro-Max™ booster and master cylinder may be mounted remotely from the vehicle dash panel and actuated by appropriate linkage.

Four mounting holes are provided in the booster housing through which up to four studs can be pressed. Use of (Grade 5) 3/8-16 or M10 locknuts, having self-contained prevailing torque features that are frictionally resistant to rotation, are recommended.

See *Figure 12* for the three basic pedal rod designs offered. The threaded pedal rod screws into the customer supplied attachment to the brake pedal. The pin that attaches the pedal rod to the brake pedal must insert freely. The attachment mechanism of the pedal rod should be of sufficient strength to prevent linkage binding.

524

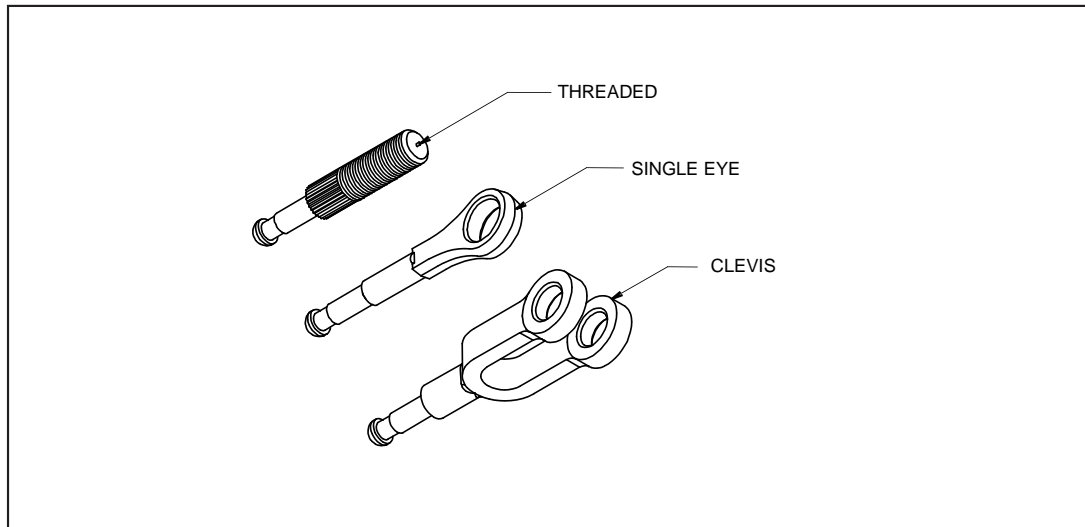

Figure 12 Basic Pedal Rod Designs



**BOSCH**

ATTENTION

Regardless of mounting location, the following requirements **must** be followed:

- a. Mount the unit such that the pedal rod, throughout full pedal travel, does not articulate more than plus or minus 5° above or below booster centerline. The brake pedal lever must be aligned side to side with the booster centerline to prevent linkage binding.
- b. The brake pedal and mechanical linkage **must** provide enough travel to fully stroke both booster and master cylinder, i.e., the brake pedal must not bottom on the floor of the vehicle. A pedal ratio of between 2.8:1 and 3.3:1 is recommended to provide the desired "pedal feel".
- c. The Hydro-Max™ booster and master cylinder assembly **must** be mounted horizontally.
- d. The reservoir of the master cylinder **must** be upright. The backup pump must always be at the bottom of the booster.
- e. The unit **must** be protected from environmental and fluid temperatures over 250°F.

525

General Safety Note

Unique usage or applications of the Hydro-Max™ booster and master cylinder assembly requires input from Bosch and validation by the vehicle manufacturer.

Pedal Return Springs

Any vehicle application utilizing a Hydro-Max™ booster and a brake pedal return spring must have:

1. A properly adjusted pedal stop
2. A limited spring load at the pedal released position.



BOSCH

Pedal Stop and Proper Spring Load

The pedal stop must be adjusted such that when the brake pedal is fully released, there is no load on the grommet that retains the pedal rod to the Hydro-Max™ booster. When the brake pedal is fully released, the spring load must not be greater than that required to support the pedal weight.

The reason for a properly adjusted pedal stop and for the limitation on spring load is to prevent the spring from pulling on the grommet within the Hydro-Max™ booster and damaging the grommet. The grommet is not designed to be loaded in this manner.

Any adjustment of the brake switch and backup pump must not compromise the adjustment of the pedal stop.

⚠ CAUTION

It is a common practice to stack vehicles on top of each other to deliver the vehicles. An air cylinder is typically used to apply the brake pedals in the towed vehicles. When installing such a cylinder, be sure that the backup pump turns off when the towing vehicle brake pedal is released.





BOSCH

TROUBLE SHOOTING

Condition	Cause	Remedy
Hard Pedal	Binding pedal linkage	Contact dealer for service
	Pedal misalignment (side to side)	Contact dealer for service
	Low booster supply flow	Repair/replace power steering pump, check tension in belt
	Power steering pump flow control valve	Repair/replace power steering pump, check tension in belt
	Power steering pump relief valve setting too low	Replace power steering pump
	Fluid contamination	See vehicle service manual for type of fluid required. Drain, flush and refill system, replace booster or master cylinder as appropriate, and power steering reservoir filter as necessary
	Master cylinder	Replace master cylinder
Excessive pedal travel (pedal goes to the floor)	Booster	Replace booster
	Tube and hose passages are blocked shut	Replace parts containing blocked passages
	Improper pedal adjustment	See vehicle service manual for pedal rod adjustment (if system is adjustable)

527

BOSCH

TROUBLE SHOOTING

Condition	Cause	Remedy
Excessive pedal travel (pedal goes to the floor) (continued)	External leak in brake fluid system	Check all fittings and connections for the master cylinder, calipers, hoses, and tubes, replace if necessary
	Internal master cylinder leak	Replace master cylinder
	Air in brake fluid system	Bleed system
	Brake linings	Inspect and adjust, or replace brake shoes, if necessary
Pulsating brake pedal	Master cylinder	Replace master cylinder
	Weak brake hoses that expand under pressure	Replace hoses
	Poor quality brake fluid (low boil point)	Drain the system, flush and refill with the recommended fluid.
	Brake self adjusting mechanism	See vehicle service manual (if brakes are adjustable)
Soft, spongy brakes	Air in hydraulic brake system	Bleed brake system
	Poor quality brake fluid (low boil point)	Drain the system, flush and refill with recommended fluid
	Weak brake hoses that expand under pressure	Replace defective hoses
Actuated pedal does not return	Binding pedal linkage	Contact dealer for service

528





BOSCH

TROUBLE SHOOTING

Condition	Cause	Remedy
Actuated pedal does not return <i>(continued)</i>	Fluid contamination	See vehicle service manual for type of fluid required. Drain, flush and refill system, replace booster or master cylinder as appropriate, and power steering reservoir filter as necessary
	Master cylinder	Replace master cylinder
	Binding booster	Replace booster
	Self applied booster (fluid flow too high)	Repair or replace power steering pump.
Pulsating brake pedal	ABS operation	See appropriate service manual
	Wheel bearings loose or worn	See appropriate service manual
	Excessive rotor hickness variation	See appropriate service manual
	Parking brake control valve (HR1) has internal leak	See appropriate service manual
Brake self apply	Self applied booster (fluid flow too high)	Repair or replace power steering pump
	Constricted master cylinder reservoir vent	Clean vent passage in reservoir cap
Dragging brake	Self applied booster (fluid flow too high)	Repair or replace power steering pump

529



BOSCH

TROUBLE SHOOTING

Condition	Cause	Remedy
Dragging brake <i>(continued)</i>	Stuck or bound caliper pins or rails	See appropriate service manual
	Binding booster	Replace booster
	Binding pedal linkage	Contact dealer for service
	Master cylinder	Replace master cylinder
	Soft or swollen master cylinder seals due to brake fluid contamination	Flush out old brake fluid then replace master cylinder and add new brake fluid
	Tube and hose passages restricted	Replace the parts containing the restriction
Noise / Whistle	Inherent in some boosters (whistle)	None - Does not affect operation
Backup pump operates continuously	Brake switch	See vehicle service manual
	Monitor module	See vehicle service manual
	Relay	See vehicle service manual
	Flow switch	Remove switch components, clean, inspect for damage or contamination and replace if necessary
	Binding pedal linkage	Contact dealer for service

530





BOSCH

TROUBLE SHOOTING

Condition	Cause	Remedy
Backup pump does not operate	Same as above	Repeat as above
	Electrical ground	See service manual
	Backup pump	Replace backup pump
Leakage	Master cylinder	Replace master cylinder
	Booster	Replace booster
	Master cylinder reservoir vent caps	Replace diaphragms and caps
	Fluid contamination	See vehicle service manual for type of fluid required. Drain, flush and refill system, replace booster or master cylinder as appropriate, and power steering reservoir filter as necessary
	Backup pump mounting seals	Replace seals
	Flow switch seal	Replace o-ring
Hydraulic fittings and connections	Hydraulic fittings and connections	See vehicle service manual, tighten and replace if necessary
Silicone floating in master cylinder	This material is an assembly lubricant	None - Does not affect operation

531

BOSCH

TROUBLE SHOOTING

Condition	Cause	Remedy
Fluid level indicator light comes on	Low fluid level Fluid level indicator switch Brake pads worn out	Inspect brake pads, replace as necessary, add fluid as required Replace master cylinder Inspect brake pads, replace as necessary, add fluid as required
Brake indicator light and buzzer malfunction	Vehicle specific	See vehicle service manual

532





Correspondence concerning this manual should be
addressed to:

Robert Bosch Corporation
Hydraulic Actuation & Truck Brake Engineering
401 North Bendix Drive
South Bend, Indiana 46628

Fax: 574-237-2210

Printed in the United States of America
Copyright © 2002 Robert Bosch Corporation

**MERITOR WABCO**

Maintenance Manual MM-0677

Hydraulic Anti-Lock Braking Systems (HABS) for Medium-Duty Trucks, Buses and Motor Home Chassis For E Version Hydraulic ABS

Issued 09-07

535

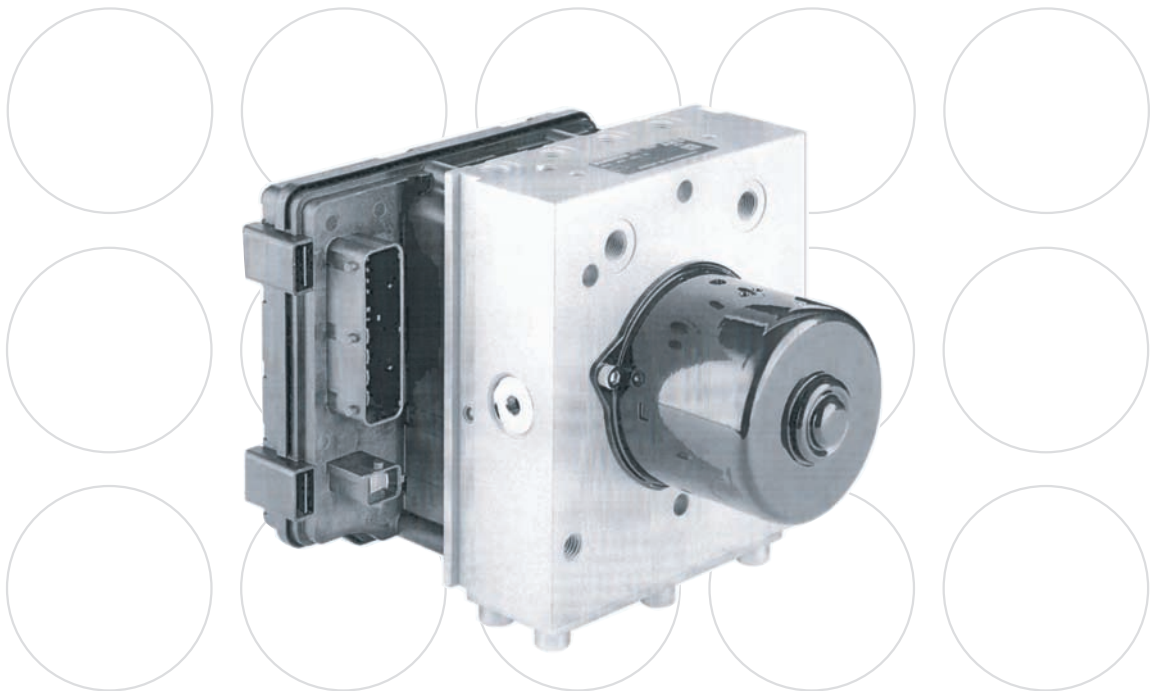

Service Notes

About This Manual

This manual provides instructions for Meritor WABCO's E Version hydraulic anti-lock braking system (HABS) for medium-duty trucks, buses and motor home chassis.

Before You Begin

1. Read and understand all instructions and procedures before you begin to service components.
2. Read and observe all Warning and Caution hazard alert messages in this publication. They provide information that can help prevent serious personal injury, damage to components, or both.
3. Follow your company's maintenance and service, installation, and diagnostics guidelines.
4. Use special tools when required to help avoid serious personal injury and damage to components.

Hazard Alert Messages and Torque Symbols

WARNING

A Warning alerts you to an instruction or procedure that you must follow exactly to avoid serious personal injury and damage to components.

CAUTION

A Caution alerts you to an instruction or procedure that you must follow exactly to avoid damage to components.

 This symbol alerts you to tighten fasteners to a specified torque value.

How to Obtain Additional Maintenance and Service Information

On the Web

Visit Literature on Demand at arvinmeritor.com to access and order product, service, aftermarket, and warranty literature for ArvinMeritor's truck, trailer and specialty vehicle components. Meritor WABCO publications are also available on our website: www.meritorwabco.com

Literature on Demand DVD (LODonDVD)

The LODonDVD contains product, service and warranty information for ArvinMeritor and Meritor WABCO products. To order the DVD, visit Literature on Demand at arvinmeritor.com and specify TP-0742.

How to Obtain Tools and Supplies Specified in This Manual

Call ArvinMeritor's Commercial Vehicle Aftermarket at 888-725-9355 to obtain Meritor tools and supplies.

Information contained in this publication was in effect at the time the publication was approved for printing and is subject to change without notice or liability. Meritor WABCO reserves the right to revise the information presented or to discontinue the production of parts described at any time.



Contents

pg. i	Asbestos and Non-Asbestos Fibers
1	Section 1: Introduction
	Maintenance
	Manual Information
	Overview
	How Hydraulic ABS Works
2	System Layout
	System Components
	Electronic Control Unit (ECU)
3	Modulator Assembly
	Sensors
4	ABS Indicator Lamp
	TOOLBOX™ Software
5	Section 2: Troubleshooting and Testing
	Maintenance
	General Information
	Wiring Diagrams
	System Wiring Information
6	System Diagnostics
	Meritor WABCO TOOLBOX™ Software
8	Blink Code Diagnostics
	Using Blink Code Diagnostics
13	Testing the System
	Meritor WABCO TOOLBOX™ Software
	E Version Hydraulic ABS Menus and Toolbars
18	Standard Testing
	System Requirements and Component Tests
	Standard Component Testing
20	Section 3: Component Replacement
	Component Removal and Installation
	Sensors
	Wheel Speed Sensor Replacement — Front Axle
	Wheel Speed Sensor Replacement — Rear Axle
21	Electronic Control Unit (ECU)
22	Modulator Assembly
23	Brake Bleeding Procedures
	Pressure Fill and Bleed

Asbestos and Non-Asbestos Fibers

ASBESTOS FIBERS WARNING

The following procedures for servicing brakes are recommended to reduce exposure to asbestos fiber dust, a cancer and lung disease hazard. Material Safety Data Sheets are available from ArvinMeritor.

Hazard Summary

Because some brake linings contain asbestos, workers who service brakes must understand the potential hazards of asbestos and precautions for reducing risks. Exposure to airborne asbestos dust can cause serious and possibly fatal diseases, including asbestosis (a chronic lung disease) and cancer, principally lung cancer and mesothelioma (a cancer of the lining of the chest or abdominal cavities). Some studies show that the risk of lung cancer among persons who smoke and who are exposed to asbestos is much greater than the risk for non-smokers. Symptoms of these diseases may not become apparent for 15, 20 or more years after the first exposure to asbestos.

Accordingly, workers must use caution to avoid creating and breathing dust when servicing brakes. Specific recommended work practices for reducing exposure to asbestos dust follow. Consult your employer for more details.

Recommended Work Practices

1. **Separate Work Areas.** Whenever feasible, service brakes in a separate area away from other operations to reduce risks to unprotected persons. OSHA has set a maximum allowable level of exposure for asbestos of 0.1 f/cc as an 8-hour time-weighted average and 1.0 f/cc averaged over a 30-minute period. Scientists disagree, however, to what extent adherence to the maximum allowable exposure levels will eliminate the risk of disease that can result from inhaling asbestos dust. OSHA requires that the following sign be posted at the entrance to areas where exposures exceed either of the maximum allowable levels:

DANGER: ASBESTOS
CANCER AND LUNG DISEASE HAZARD
AUTHORIZED PERSONNEL ONLY
RESPIRATORS AND PROTECTIVE CLOTHING
ARE REQUIRED IN THIS AREA.

2. **Respiratory Protection.** Wear a respirator equipped with a high-efficiency (HEPA) filter approved by NIOSH or MSHA for use with asbestos at all times when servicing brakes, beginning with the removal of the wheels.

3. **Procedures for Servicing Brakes.**

a. Enclose the brake assembly within a negative pressure enclosure. The enclosure should be equipped with a HEPA vacuum and worker arm sleeves. With the enclosure in place, use the HEPA vacuum to loosen and vacuum residue from the brake parts.

b. As an alternative procedure, use a catch basin with water and a biodegradable, non-phosphate, water-based detergent to wash the brake drum or rotor and other brake parts. The solution should be applied with low pressure to prevent dust from becoming airborne. Allow the solution to flow between the brake drum and the brake support or the brake rotor and caliper. The wheel hub and brake assembly components should be thoroughly wetted to suppress dust before the brake shoes or brake pads are removed. Wipe the brake parts clean with a cloth.

c. If an enclosed vacuum system or brake washing equipment is not available, employers may adopt their own written procedures for servicing brakes, provided that the exposure levels associated with the employer's procedures do not exceed the levels associated with the enclosed vacuum system or brake washing equipment. Consult OSHA regulations for more details.

d. Wear a respirator equipped with a HEPA filter approved by NIOSH or MSHA for use with asbestos when grinding or machining brake linings. In addition, do such work in an area with a local exhaust ventilation system equipped with a HEPA filter.

e. **NEVER** use compressed air by itself, dry brushing, or a vacuum not equipped with a HEPA filter when cleaning brake parts or assemblies. **NEVER** use carcinogenic solvents, flammable solvents, or solvents that can damage brake components as wetting agents.

4. **Cleaning Work Areas.** Clean work areas with a vacuum equipped with a HEPA filter or by wet wiping. **NEVER** use compressed air or dry sweeping to clean work areas. When you empty vacuum cleaners and handle used rags, wear a respirator equipped with a HEPA filter approved by NIOSH or MSHA for use with asbestos. When you replace a HEPA filter, wet the filter with a fine mist of water and dispose of the used filter with care.

5. **Worker Clean-Up.** After servicing brakes, wash your hands before you eat, drink or smoke. Shower after work. Do not wear work clothes home. Use a vacuum equipped with a HEPA filter to vacuum work clothes after they are worn. Launder them separately. Do not shake or use compressed air to remove dust from work clothes.

6. **Waste Disposal.** Dispose of discarded linings, used rags, cloths and HEPA filters with care, such as in sealed plastic bags. Consult applicable EPA, state and local regulations on waste disposal.

Regulatory Guidance

References to OSHA, NIOSH, MSHA, and EPA, which are regulatory agencies in the United States, are made to provide further guidance to employers and workers employed within the United States. Employers and workers employed outside of the United States should consult the regulations that apply to them for further guidance.

NON-ASBESTOS FIBERS WARNING

The following procedures for servicing brakes are recommended to reduce exposure to non-asbestos fiber dust, a cancer and lung disease hazard. Material Safety Data Sheets are available from ArvinMeritor.

Hazard Summary

Most recently manufactured brake linings do not contain asbestos fibers. These brake linings may contain one or more of a variety of ingredients, including glass fibers, mineral wool, aramid fibers, ceramic fibers and silica that can present health risks if inhaled. Scientists disagree on the extent of the risks from exposure to these substances. Nonetheless, exposure to silica dust can cause silicosis, a non-cancerous lung disease. Silicosis gradually reduces lung capacity and efficiency and can result in serious breathing difficulty. Some scientists believe other types of non-asbestos fibers, when inhaled, can cause similar diseases of the lung. In addition, silica dust and ceramic fiber dust are known to the State of California to cause lung cancer. U.S. and international agencies have also determined that dust from mineral wool, ceramic fibers and silica are potential causes of cancer.

Accordingly, workers must use caution to avoid creating and breathing dust when servicing brakes. Specific recommended work practices for reducing exposure to non-asbestos dust follow. Consult your employer for more details.

Recommended Work Practices

1. **Separate Work Areas.** Whenever feasible, service brakes in a separate area away from other operations to reduce risks to unprotected persons.

2. **Respiratory Protection.** OSHA has set a maximum allowable level of exposure for silica of 0.1 mg/m³ as an 8-hour time-weighted average. Some manufacturers of non-asbestos brake linings recommend that exposures to other ingredients found in non-asbestos brake linings be kept below 1.0 f/cc as an 8-hour time-weighted average. Scientists disagree, however, to what extent adherence to these maximum allowable exposure levels will eliminate the risk of disease that can result from inhaling non-asbestos dust.

Therefore, wear respiratory protection at all times during brake servicing, beginning with the removal of the wheels. Wear a respirator equipped with a high-efficiency (HEPA) filter approved by NIOSH or MSHA, if the exposure levels may exceed OSHA or manufacturers' recommended maximum levels. Even when exposures are expected to be within the maximum allowable levels, wearing such a respirator at all times during brake servicing will help minimize exposure.

3. **Procedures for Servicing Brakes.**

a. Enclose the brake assembly within a negative pressure enclosure. The enclosure should be equipped with a HEPA vacuum and worker arm sleeves. With the enclosure in place, use the HEPA vacuum to loosen and vacuum residue from the brake parts.

b. As an alternative procedure, use a catch basin with water and a biodegradable, non-phosphate, water-based detergent to wash the brake drum or rotor and other brake parts. The solution should be applied with low pressure to prevent dust from becoming airborne. Allow the solution to flow between the brake drum and the brake support or the brake rotor and caliper. The wheel hub and brake assembly components should be thoroughly wetted to suppress dust before the brake shoes or brake pads are removed. Wipe the brake parts clean with a cloth.

c. If an enclosed vacuum system or brake washing equipment is not available, carefully clean the brake parts in the open air. Wet the parts with a solution applied with a pump-spray bottle that creates a fine mist. Use a solution containing water, and, if available, a biodegradable, non-phosphate, water-based detergent. The wheel hub and brake assembly components should be thoroughly wetted to suppress dust before the brake shoes or brake pads are removed. Wipe the brake parts clean with a cloth.

d. Wear a respirator equipped with a HEPA filter approved by NIOSH or MSHA when grinding or machining brake linings. In addition, do such work in an area with a local exhaust ventilation system equipped with a HEPA filter.

e. **NEVER** use compressed air by itself, dry brushing, or a vacuum not equipped with a HEPA filter when cleaning brake parts or assemblies. **NEVER** use carcinogenic solvents, flammable solvents, or solvents that can damage brake components as wetting agents.

4. **Cleaning Work Areas.** Clean work areas with a vacuum equipped with a HEPA filter or by wet wiping. **NEVER** use compressed air or dry sweeping to clean work areas. When you empty vacuum cleaners and handle used rags, wear a respirator equipped with a HEPA filter approved by NIOSH or MSHA, to minimize exposure. When you replace a HEPA filter, wet the filter with a fine mist of water and dispose of the used filter with care.

5. **Worker Clean-Up.** After servicing brakes, wash your hands before you eat, drink or smoke. Shower after work. Do not wear work clothes home. Use a vacuum equipped with a HEPA filter to vacuum work clothes after they are worn. Launder them separately. Do not shake or use compressed air to remove dust from work clothes.

6. **Waste Disposal.** Dispose of discarded linings, used rags, cloths and HEPA filters with care, such as in sealed plastic bags. Consult applicable EPA, state and local regulations on waste disposal.

Regulatory Guidance

References to OSHA, NIOSH, MSHA, and EPA, which are regulatory agencies in the United States, are made to provide further guidance to employers and workers employed within the United States. Employers and workers employed outside of the United States should consult the regulations that apply to them for further guidance.



1 Introduction

Maintenance

Manual Information

This manual contains service information for the Meritor WABCO **E Version** hydraulic ABS. For earlier versions of Meritor WABCO HABS, refer to:

- MM38 **C Version** HABS
- MM39 **D Version** HABS

Copies of these manuals are posted on our website:
meritorwabco.com.

Overview

Meritor WABCO Hydraulic Anti-lock Braking System (HABS) is an electronic wheel speed monitoring and control system used on medium-duty trucks, buses and motor home chassis equipped with a hydraulic brake system.

E Version HABS consists of an electronic control unit (ECU) mounted directly on a modulator valve. Typically, the modulator valve is mounted on the frame rail of the vehicle. Figure 1.1.

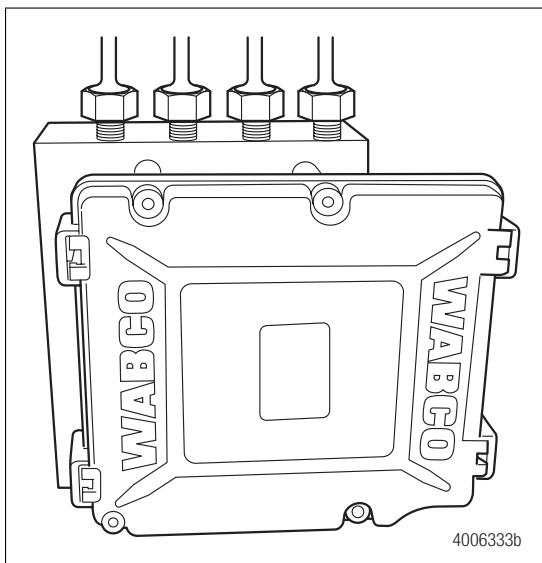

Figure 1.1

How Hydraulic ABS Works

ABS wheel sensors detect wheel speeds. The sensors generate signals that are transmitted to an ECU. If the wheels start to lock, the ECU signals the modulator assembly to regulate the brake pressure of each locking wheel.

During an ABS stop, a solenoid valve in the modulator assembly is rapidly pulsed; that is, it opens and closes several times per second to control the brake pressure. When this occurs, drivers may notice a pulsation of the brake pedal.

An ABS indicator lamp on the vehicle instrument panel alerts the driver to a possible system fault and provides blink code information to diagnose the system.

If the ABS indicator lamp comes on during normal vehicle operation, drivers may complete their trip, but are instructed to have their vehicle serviced as soon as possible.

In the unlikely event of an ABS system malfunction, the ABS in the affected wheel will be disabled and will return to normal braking. The other sensed wheels will retain their ABS function.

1 Introduction

System Layout

A typical Meritor WABCO E Version HABS installation is illustrated in Figure 1.2.

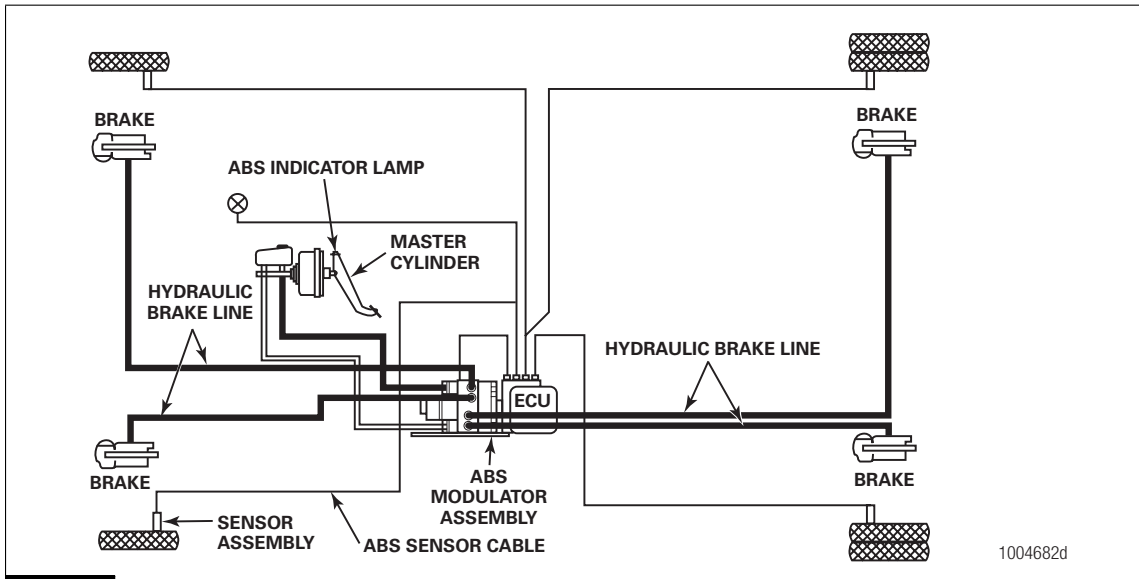

Figure 1.2

The ABS modulator assembly may be mounted in any orientation as long as the modulator is **below** the master cylinder and **above** the wheel cylinders.

System Components

The following components make up Meritor WABCO E Version HABS.

Electronic Control Unit (ECU)

The electronic control unit (ECU) processes sensor signals and generates solenoid valve commands to reduce, maintain or reapply brake pressure. Figure 1.3.

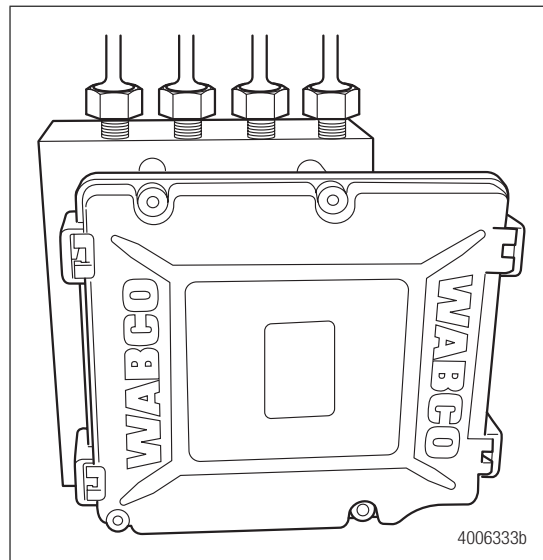

Figure 1.3



1 Introduction

Modulator Assembly

⚠ CAUTION

The modulator assembly contains brake fluid. Handle the modulator assembly with appropriate care. Do not expose the modulator assembly to impact loads or excessive vibrations. Do not blow compressed air into the hydraulic ports. Mishandling the modulator assembly may lead to component damage and system failure.

The modulator assembly houses the HABS solenoid control valves, one inlet valve and one outlet valve per wheel, a pump motor and two accumulators. Figure 1.4.

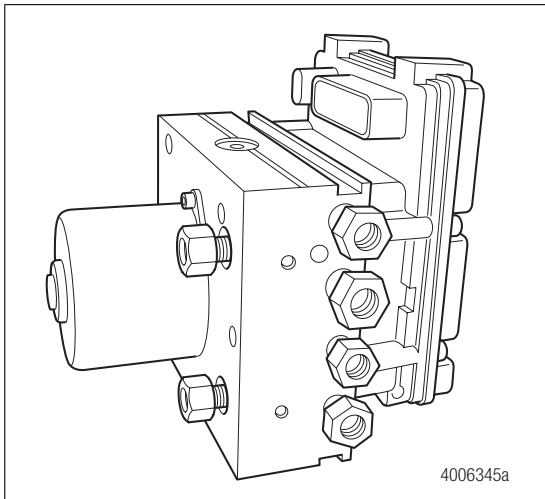

Figure 1.4

Sensors

Sensor with Molded Socket

- Measures the speed of a tooth wheel rotating with the vehicle wheel.
- Produces an output voltage proportional to wheel speed. Figure 1.5.

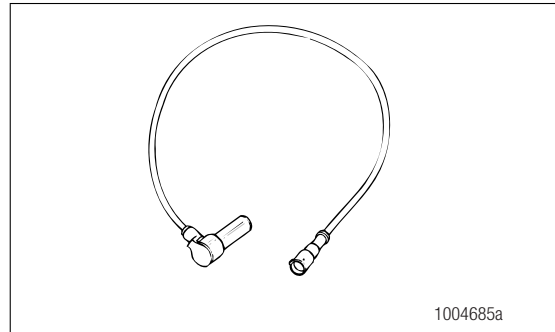

Figure 1.5

Sensor Spring Clip

- Holds the wheel speed sensor in close proximity to the tooth wheel. Figure 1.6.

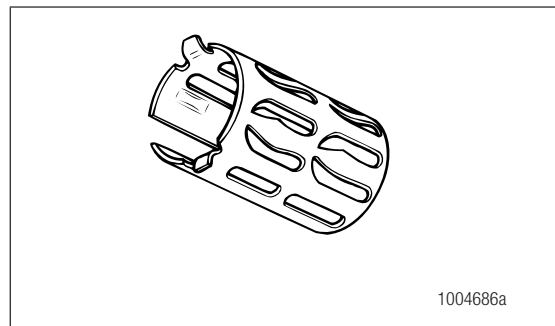

Figure 1.6

Tooth Wheel

- A machined or stamped ring mounted to a machined surface on the hub of each ABS-monitored wheel. Figure 1.7.

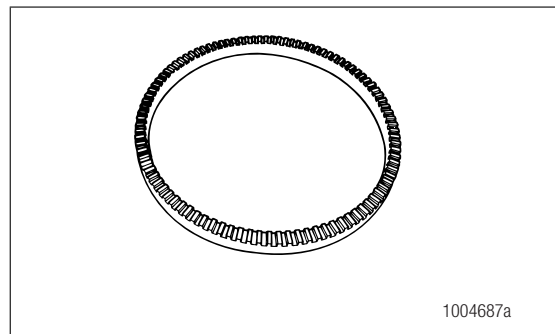

Figure 1.7

1 Introduction

Sensor Extension Cables

- Two-wire cable with molded-on connector. Figure 1.8.
- Connects the wheel speed sensor to the ECU.

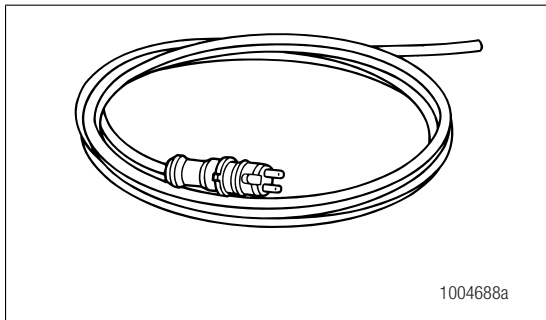

Figure 1.8

ABS Indicator Lamp

- Located on vehicle instrument panel. Figure 1.9.
- Alerts drivers to a possible system fault.
- Used by service personnel to display blink codes.
- ABS indicator lamp is not provided by Meritor WABCO.

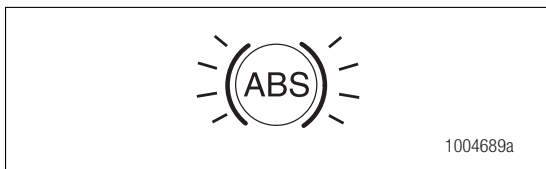

Figure 1.9

TOOLBOX™ Software

- A PC-based diagnostics program.
- Displays system faults and wheel speed data, tests individual components, verifies installation wiring and more.
- Runs in Windows® 98, ME, 2000, NT or XP. Figure 1.10.

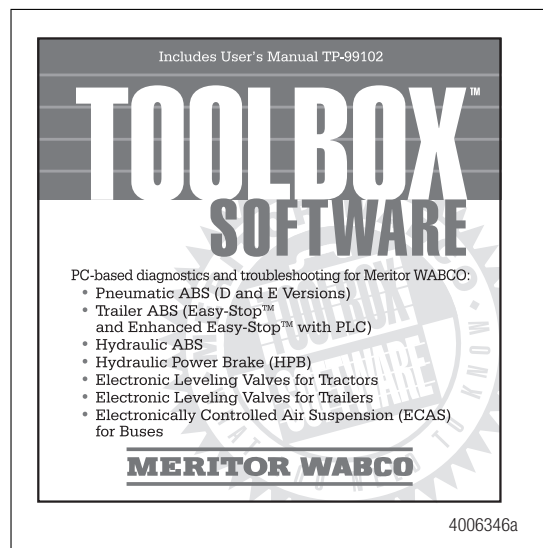

Figure 1.10

NOTE: An RS232 to J1708 converter box is required.

The program is available from SPX. Call 800-328-6657.



2 Troubleshooting and Testing

Maintenance

General Information

There is no regularly scheduled maintenance required for Meritor WABCO E Version Hydraulic ABS. However, ABS does not change current vehicle maintenance requirements. For example, it is important that the vehicle brake fluid level be correctly maintained.

Wiring Diagrams

System Wiring Information

Pin identification is shown in Figure 2.1. Wiring may vary according to the vehicle. Refer to the vehicle specifications for specific wiring diagrams. A typical Meritor WABCO Hydraulic ABS wiring diagram appears in Figure 2.2.

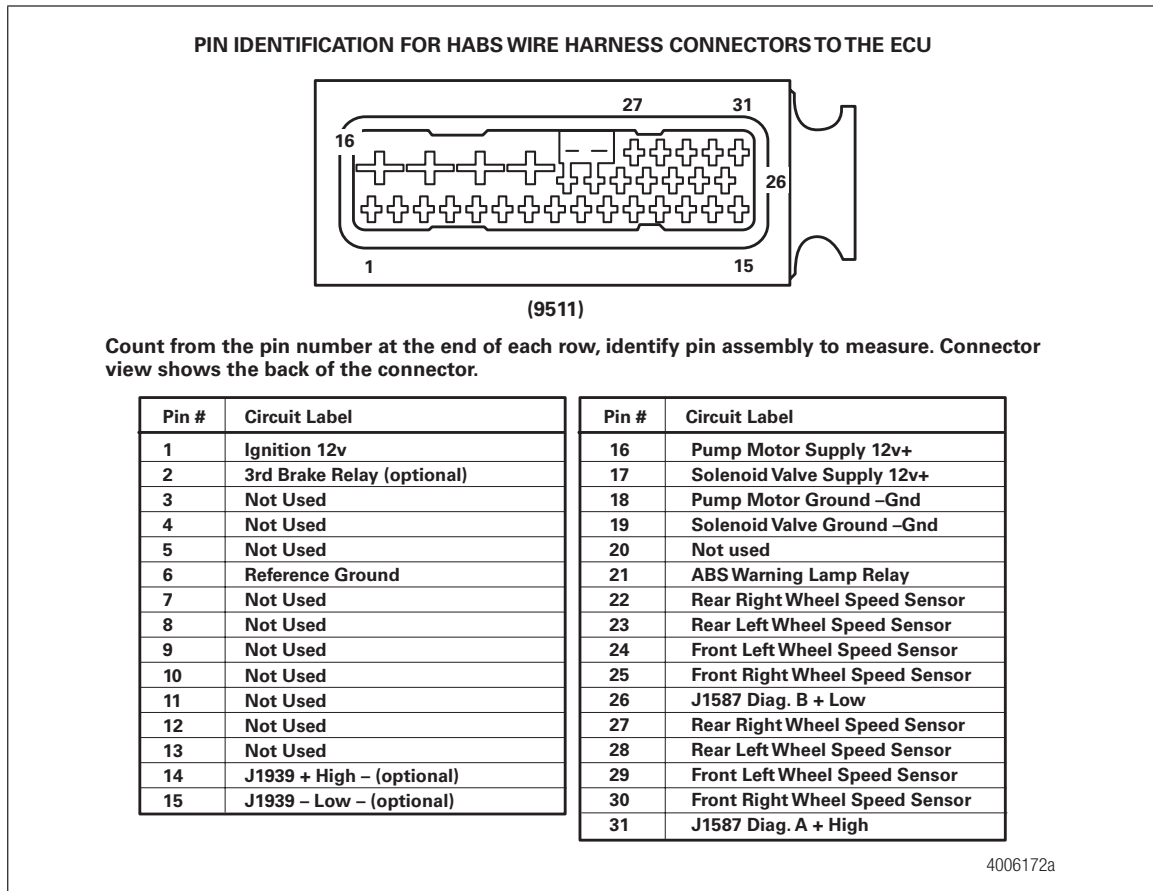

Figure 2.1



2 Troubleshooting and Testing

544

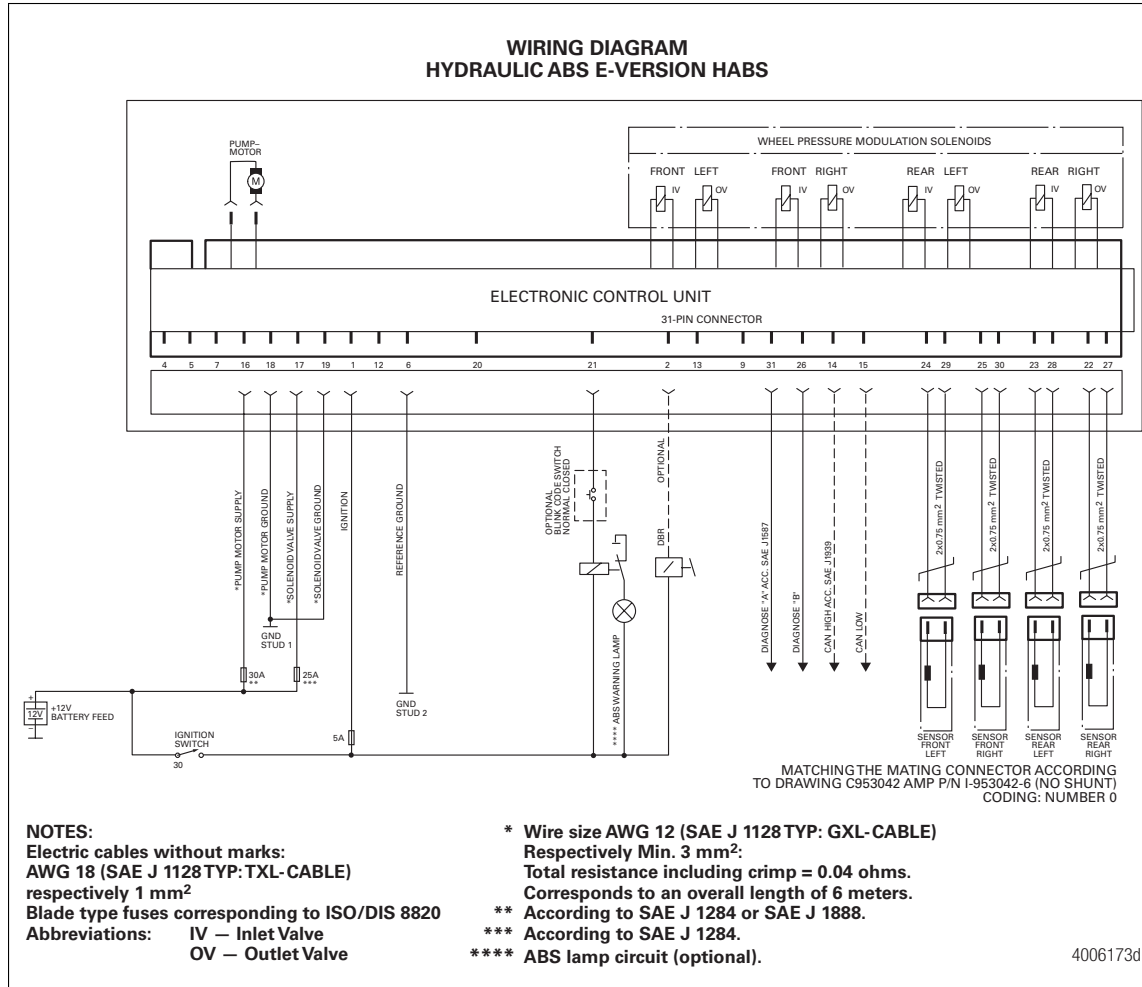

Figure 2.2

System Diagnostics

Use Meritor WABCO's PC-based diagnostic program, TOOLBOX™ Software, or standard blink codes to diagnose hydraulic ABS faults. Information for using standard blink codes appears in Table A in this section.

Meritor WABCO TOOLBOX™ Software

NOTE: For complete instructions for using this program, refer to the User's Manual, TP-99102. Contact Meritor WABCO at 800-535-5560 for information about TOOLBOX™ Software.

If you have TOOLBOX™ Software installed on your computer, use it to identify system faults. Then, follow the on-screen repair information to make the necessary repairs or replacements.

To display Hydraulic ABS faults, use the pull-down menu or the HABS icon, Figure 2.3, to select HABS (Hydraulic ABS) from the **Main Menu**. The **Hydraulic ABS Main Menu** will appear. Figure 2.4.

Select the View ECU Faults icon or select Display Faults to use the pull-down menu. Figure 2.5. This will display the **Fault Information** screen. Figure 2.6.



2 Troubleshooting and Testing

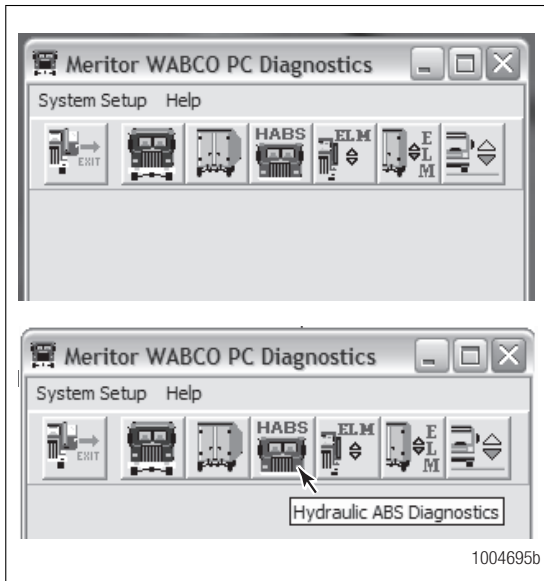

Figure 2.3

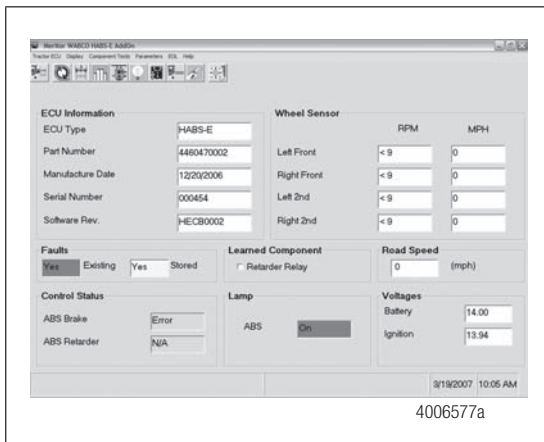

Figure 2.4

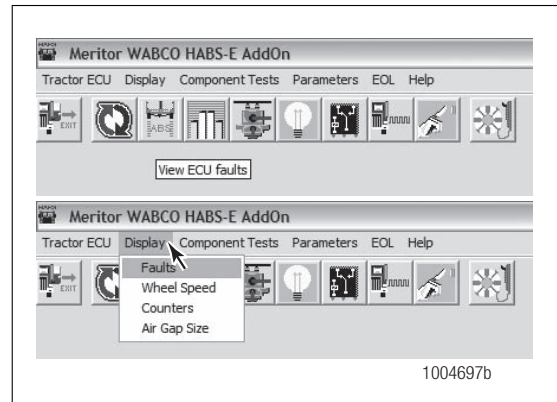

Figure 2.5

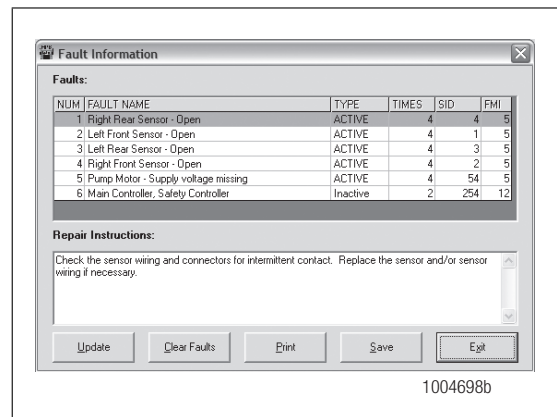

Figure 2.6

The **Fault Information** screen contains a description of the fault. Repair instructions for each fault appear at the bottom of the screen.

Faults that occur after the screen is displayed will not appear until a screen update is requested. Use the **Update** button to refresh the fault information table.

After making the necessary repairs, use the **Clear Faults** button to clear the fault. Use the **Update** button to refresh the fault information table and display the new list of faults.



2 Troubleshooting and Testing

Blink Code Diagnostics

Definitions

ABS Indicator Lamp: This lamp, located on the vehicle instrument panel, serves two purposes:

1. Alerts drivers or service personnel to a possible fault in the hydraulic ABS, as follows:

IF the ABS indicator lamp comes on briefly then goes OFF when the ignition is turned ON . . . there are no active or stored faults in the hydraulic ABS

IF the ABS indicator lamp comes on and **stays on** AFTER the ignition is turned ON **and**

The vehicle is driven in excess of four mph (6 km/h) . . . **There may be an active fault in the hydraulic ABS**

IF the ABS indicator lamp comes on and stays on **and**

Goes OFF after the vehicle is driven in excess of four mph (6 km/h) or illuminates intermittently during driving . . . **There may be a stored fault in the hydraulic ABS**

2. Displays diagnostic blink codes for easy servicing.

Blink Code: A series of blinks or flashes that describe a particular ABS system condition. Refer to Table A and Table B in this section for blink code identification.

Blink Code Diagnostics: The ability of the Meritor WABCO ECU to sense faults in the ABS system and to define these faults via blink codes.

Blink Code Switch: A momentary switch that activates blink code diagnostic capabilities. Usually, it is mounted under the instrument panel or on the steering column. Refer to the vehicle specifications for type and location.

Clearing Fault Codes: The process of erasing faults from the ECU memory bank. Refer to Table A in this section.

Fault Code: An ABS condition (fault) detected and stored in memory by the Meritor WABCO ECU and displayed by blink code. System faults may be **Active** or **Stored**.

Active Fault: A condition that currently exists in the ABS system; for example, a sensor circuit malfunction on the left front steering axle. An active fault **must be repaired before you can display additional faults**. Once an active fault has been repaired, it becomes a stored fault.

Stored Fault: A condition that caused the system to register a fault, but **is not currently active**. For example, a loose wire that corrected itself. A stored fault can also be an active fault that has been corrected. Refer to Active Fault.

Table A, in this section, describes the method of distinguishing between active and stored faults and explains how to clear them.

Using Blink Code Diagnostics

Follow the steps listed in Table A to use blink code diagnostics. Refer to Figure 2.7 and Figure 2.8 in this section for blink code illustrations.



2 Troubleshooting and Testing

Table A: Identifying E Version Hydraulic ABS Blink Codes

Troubleshooting with Blink Code Diagnostics			
Mode	Procedure	System Response	Action
Diagnostics	Step I. Turn ignition ON.	Possible responses:	
		1. ABS indicator lamp comes on momentarily then goes out, indicating System O.K.	No recognizable active faults in the ABS. No action required.
		2. ABS indicator lamp does not light, indicating possible wiring fault or burned-out bulb.	Inspect wiring. Inspect bulb. Make the necessary repairs.
	Step II. Press and hold Blink Code Switch for one second, then release.	3. ABS indicator lamp stays on, indicating: <ul style="list-style-type: none"> • Fault, or faults, in the system • Sensor fault during last operation • Faults cleared from ECU, but vehicle not driven. • ECU disconnected. 	Continue with blink code diagnostics. Go to Step II. Continue with blink code diagnostics. Go to Step II. Drive vehicle — lamp will go out when vehicle reaches four mph (6 km/h). Connect ECU.
		ABS indicator lamp begins flashing two-digit blink code(s).	Determine if fault is active or stored: Active Fault: Lamp will repeatedly display one code. Stored Fault: Lamp will display code for each stored fault then stop blinking. Faults will be displayed one time only .
		Step III. Count the flashes to determine the blink code.	First Digit: 1-8 flashes, Pause (1-1/2 seconds). Second Digit: 1-8 flashes, Pause (4 seconds).
Step IV. Turn ignition OFF. Repair and Record faults	Active Fault.	Make the necessary repairs.	
	Stored Faults.	Record for future reference.	
Clear	Step V. Turn ignition ON. Clear faults from memory: Press and hold blink code switch for at least three seconds, then release.	ABS indicator lamp flashes eight times.	All stored faults successfully cleared. Turn ignition OFF. Turn ignition ON. The indicator lamp will stay on. This is because the ECU is looking for wheel speed. Drive the vehicle at a speed of four mph (6 km/h). Once the ECU senses wheel speed, the lamp will go off.
		Eight flashes not received.	Active faults still exist, repeat Step I through Step V.

NOTE: If you receive a blink code that is not identified in this manual, contact the Customer Support Center at 800-535-5560.

2 Troubleshooting and Testing

Blink Codes Illustrated

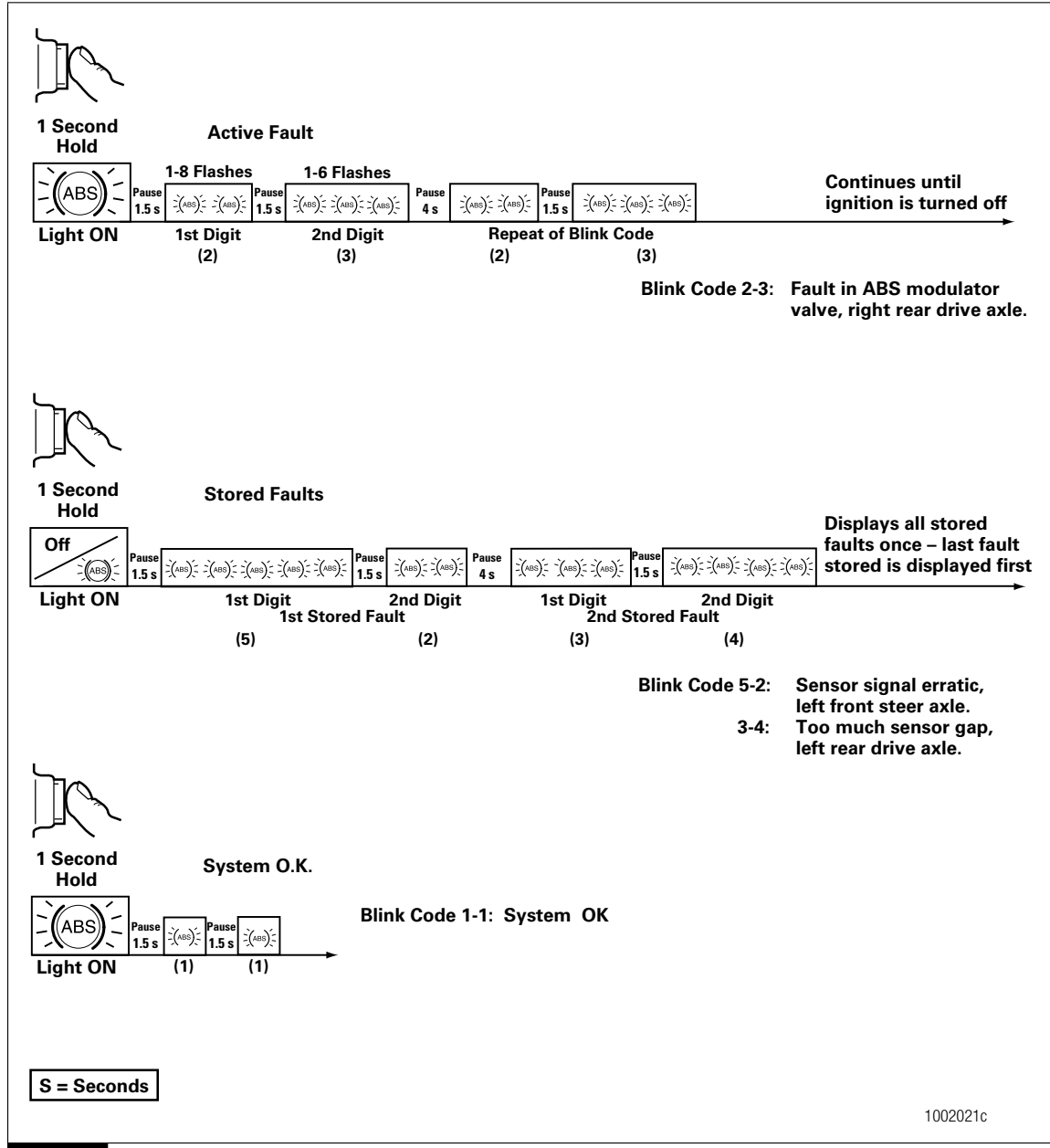

Figure 2.7



2 Troubleshooting and Testing

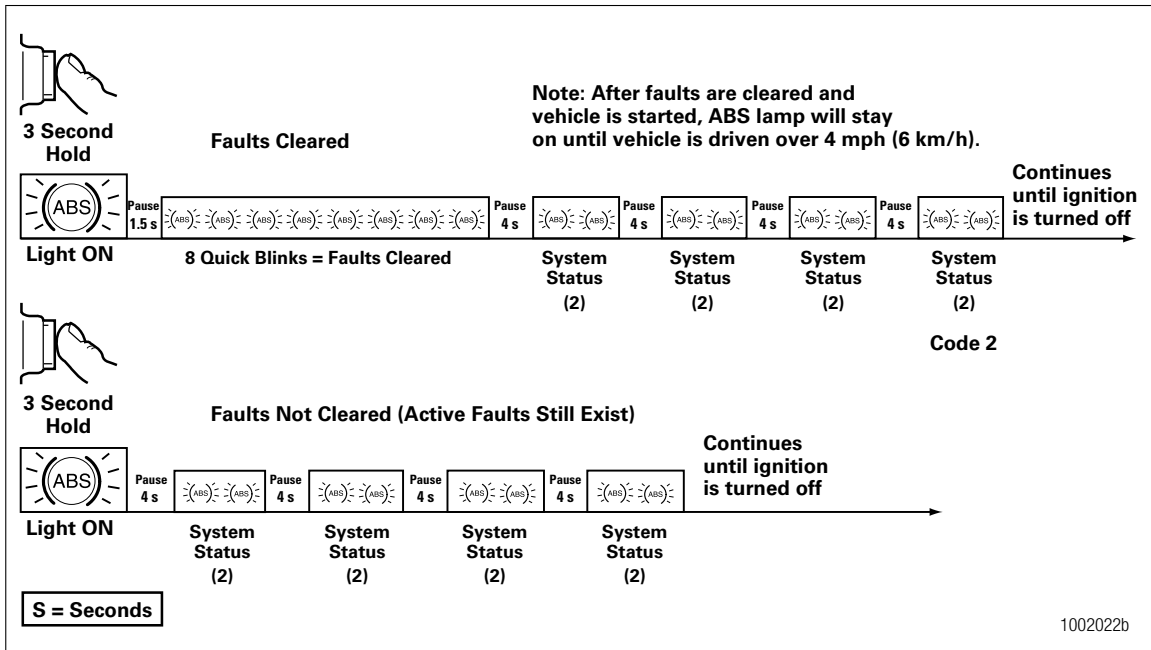

Figure 2.8

E Version Hydraulic ABS Blink Codes

Use the information in Table B to identify a fault, check for correct volt or ohm measurements and repair the fault.

1. Identify and record the blink code. Blink codes are identified in Column 1.
2. Test the pins indicated. Pin locations to be tested are listed in Column 2.
3. Compare the measurement received against the correct volt or ohm measurement listed in Column 3.
4. Follow the instructions listed in Column 4.

2 Troubleshooting and Testing

Table B: E Version Hydraulic ABS Blink Codes

Ignition Key ON to determine ABS blink code fault		Ignition Key OFF to test system (except where noted)		
Fault Code	Column 1	Column 2	Column 3	Column 4
	Problem Area	Pins to be Tested	Correct Volt Ohm Meter Readings	Action
1-1	System OK			None required
2-1	Right Front Solenoid valve (inlet or outlet valve) failure in modulator, wiring harness or inside ECU	17 and 19	12 VDC Less than 1 ohm to chassis ground w/key-off	Check pin 17 for 12 volts. Check fuse. Check pin 19 for 1 ohm or less to chassis ground w/ key-off.
2-2	Left Front Solenoid valve (inlet or outlet valve) failure in modulator, wiring harness or inside ECU			
2-3	Right Rear Solenoid valve (inlet or outlet valve) failure in modulator, wiring harness or inside ECU			
2-4	Left Rear Solenoid valve (inlet or outlet valve) failure in modulator, wiring harness or inside ECU			
2-7	Reference to ground interrupted	6		Check HABS ground connections. Make necessary repairs. Check pin 6 for ≤ 1 ohm to chassis ground w/key-off.
3-1	Right Front sensor — Air gap	25 and 30	Greater than 0.2 volt AC at 30 rpm <i>(Rotate wheel 1/2 revolution per second)</i>	Check for sensor adjustment. Check for excessive wheel bearing end play. Repair or replace as needed.
3-2	Left Front sensor — Air gap	24 and 29		
3-3	Right Rear sensor — Air gap	22 and 27		
3-4	Left Rear sensor — Air gap	23 and 28		
4-1	Right Front sensor — Electrical fault	25 and 30	900-2000 ohms	Check electrical resistance of affected sensor and wiring at ECU connector and at harness plugs. Repair or replace as needed.
4-2	Left Front sensor — Electrical fault	24 and 29		
4-3	Right Rear sensor — Electrical fault	22 and 27		
4-4	Left Rear sensor — Electrical fault	23 and 28		
5-1	Right Front wheel — Erratic wheel speed			Check for tire size mismatch or tooth wheel difference. Check sensor, sensor cable and connector for intermittent contact. Repair or replace as needed. Check sensor mounting and alignment.
5-2	Left Front wheel — Erratic wheel speed			
5-3	Right Rear wheel — Erratic wheel speed			
5-4	Left Rear wheel — Erratic wheel speed			
7-4	ABS indicator lamp	21	10-200 ohms	Check bulb. Repair or replace as needed.

550



2 Troubleshooting and Testing

Table B: E Version Hydraulic ABS Blink Codes

Ignition Key ON to determine ABS blink code fault		Ignition Key OFF to test system (except where noted)		
Fault Code	Column 1 Problem Area	Column 2 Pins to be Tested	Column 3 Correct Volt Ohm Meter Readings	Column 4 Action
7-7	Recirculation pump does not switch off. OR Recirculation pump does not switch on (low level with act). OR Recirculation pump motor locked.			Replace ECU.
7-8	Recirculation pump relay sticks.			
8-1	No voltage to ABS solenoid valves.	17 and 19	12 VDC	Check the valve relay, fuse and wiring. Repair or replace as needed.
8-2	Continuous supply to ECU with ignition off.			Check for correct wiring connections. Make necessary repairs. If problem persists, replace ECU.
8-3	Internal ECU Fault			Replace ECU.

551

Testing the System

This section of the manual contains information for testing the hydraulic ABS with TOOLBOX™ Software, as well as procedures for conducting standard air and electrical tests.

WARNING

To prevent serious eye injury, always wear safe eye protection when you perform vehicle maintenance or service.

Exhaust gas contains poison. When testing a vehicle with the engine running, test in a well-ventilated area or route the exhaust hose outside.

To avoid serious personal injury, keep away, and keep test equipment away, from all moving or hot engine parts.

Refer to, and follow, the vehicle manufacturer's Warnings, Cautions and Service Procedures.

When testing, set the parking brake and place the gear selector in NEUTRAL (manual transmission) or PARK (automatic transmission) unless otherwise directed.

Meritor WABCO TOOLBOX™ Software

Use TOOLBOX™ Software to verify the activation of various system components:

- Turn valves, pump and retarder relay on and off (Valve Activation Menu).
- Turn ABS indicator lamp on and off (Miscellaneous Output Activation Menu).

NOTE: TOOLBOX™ Software must be connected to the vehicle and the vehicle ignition must be ON in order to display information.

NOTE: For complete instructions for using this program, refer to the User's Manual, TP-99102. Contact Meritor WABCO at 800-535-5560 for information about TOOLBOX™ Software.

E Version Hydraulic ABS Menus and Toolbars

Select Hydraulic ABS from the TOOLBOX™ *Main Menu*. TOOLBOX™ senses the type of ECU being used and displays the *HABS Main Screen*.

2 Troubleshooting and Testing

Main Screen

This screen provides icons and pull-down menu task selections. It also provides information about the current status of Meritor WABCO HABS. Figure 2.9.

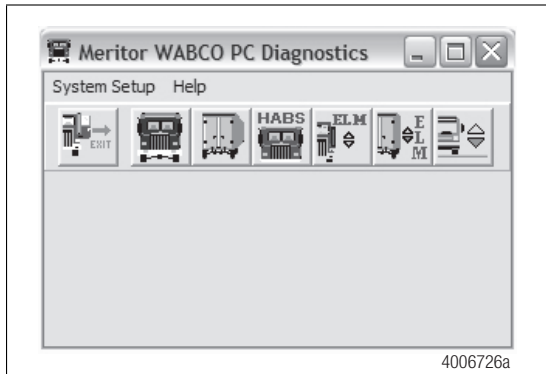

Figure 2.9

ECU information is read once from the ECU and does not change. All other information (e.g., wheel sensors, voltages and fault information) is read and updated continuously.

Display

Select **Display** from the HABS **Main Screen**. A pull-down menu will appear. Figure 2.10.



Figure 2.10

Faults

Select **Faults** to display the **Fault Information** screen. Figure 2.11.

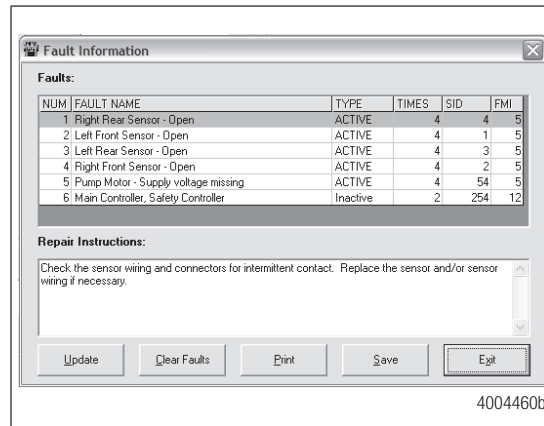

Figure 2.11

The **Fault Information** screen contains a description of each fault, including the type of fault (Active or Stored), number of occurrences, SID and FMI number. Repair instructions for the fault appear at the bottom of the screen.

Faults that occur after the screen is displayed will not appear until a screen update is requested. Use the **Update** button at the bottom of the screen to refresh the fault information table and display a new list of faults.

After making any required repairs, use the **Clear Faults** button to clear the fault. Clear each fault as it is repaired. Cycle the ignition after clearing the faults.

Use the **Save** or **Print** button to save or print the fault information data. Select **Exit** to close this section.



2 Troubleshooting and Testing

Wheel Speed

Select **Wheel Speed** to display the **Wheel Speed** screen. Figure 2.12.

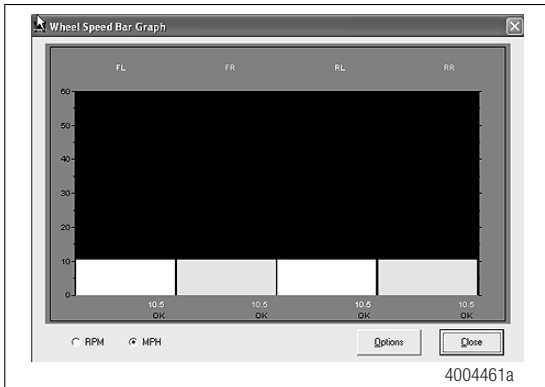

Figure 2.12

Use the **Wheel Speed** screen to verify that sensors are connected at each wheel. Speed at a sensed wheel (FL, FR, RL, RR) indicates sensors are installed, but does not verify correct sensor installation.

Counters

Select **Counters** to display the **Counters** screen. Figure 2.13.

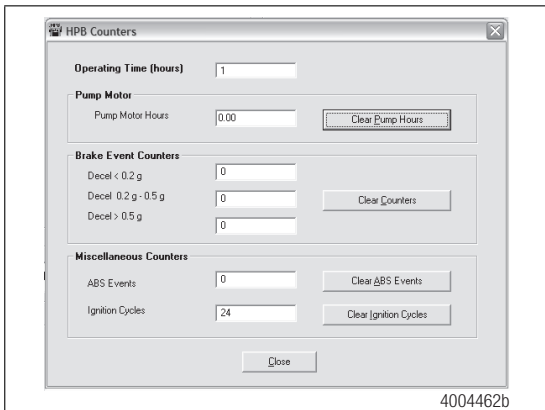

Figure 2.13

The **Counters** screen provides an overview of HABS component performance (pump hours, brake events, etc.) as well as general vehicle activity such as ignition cycles. Occurrences displayed on this screen accumulate until the **Clear** button is selected.

Component Tests

Select **Component Tests** from the HABS **Main Screen**. A pull-down menu will appear. Figure 2.14.

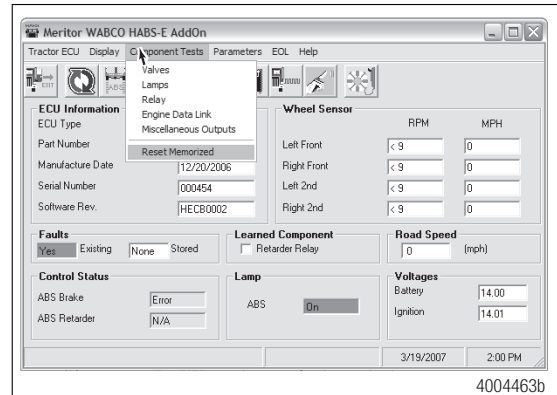

Figure 2.14

Miscellaneous Outputs

Select **Miscellaneous Outputs** to display the **Actuate Miscellaneous Outputs** test screen. Figure 2.15.

NOTE: Use TOOLBOX™ Software to test the following components: Retarder Relay, Brake Light Relay, Supply Valve, Cut-Off Valve, ABS Lamp, Traction Lamp, Brake Warning, Pump Front, Pump Rear, Buzzer.

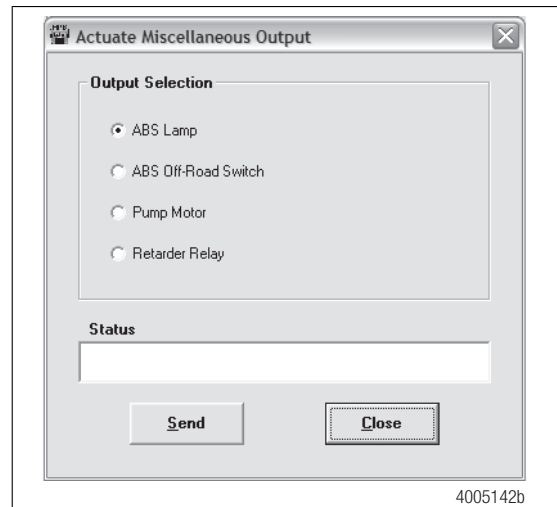

Figure 2.15



2 Troubleshooting and Testing

This screen provides a check of several HABS components, as well as a way to check either inlet or outlet activity of the valves, pump or retarder relay.

Highlight the component you wish to test, then select the **Send** button to actuate the component. Component activation status appears in the **Status Box** field. Select **Close** to exit this screen.

Valves

Select **Valves** to display the **Valve Activation** test screen. Figure 2.16.

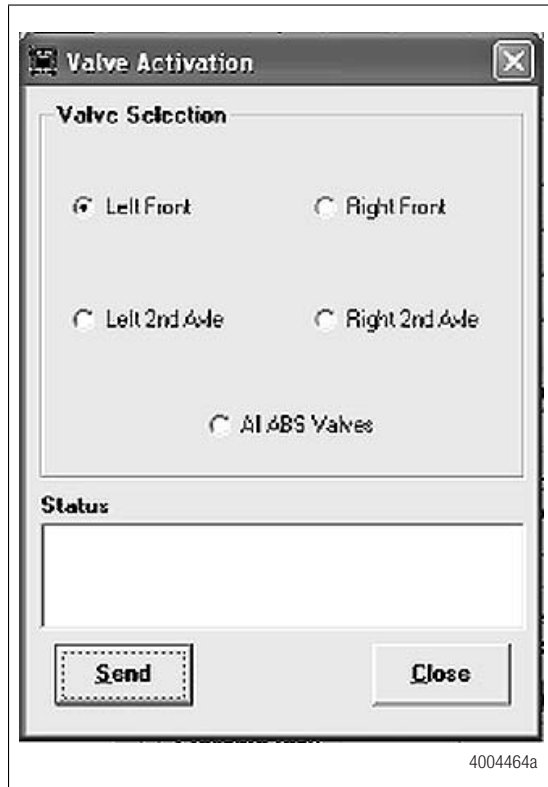

Figure 2.16

The **Valve Activation** test screen lets you activate the HABS valves to check for correct activation and to verify correct brake line installation.

Click on the valve you wish to test, then click the **Send** button to actuate the component. Component activation status appears in the **Status** box field. Select **Close** to exit this screen.

Lamps

Select **Lamps** to display the **Lamp Test** screen. Figure 2.17.

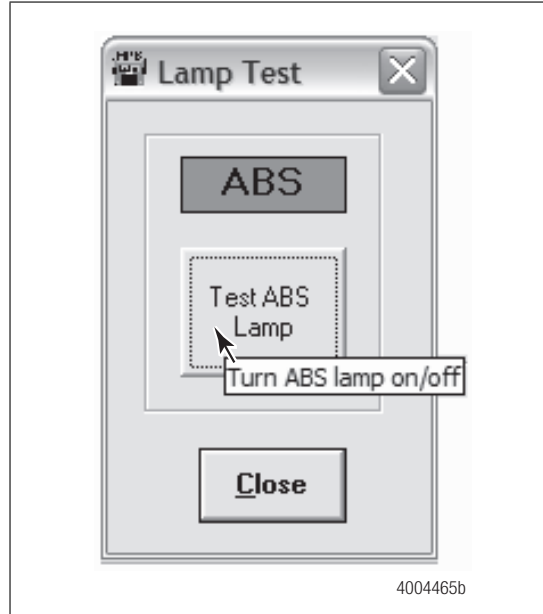

Figure 2.17

As each lamp is tested, check the actual lamp to verify correct operation. Select **Close** to exit this screen.



2 Troubleshooting and Testing

Relay

Select **Relay** to display the **Activate Relay** test screen. Figure 2.18.

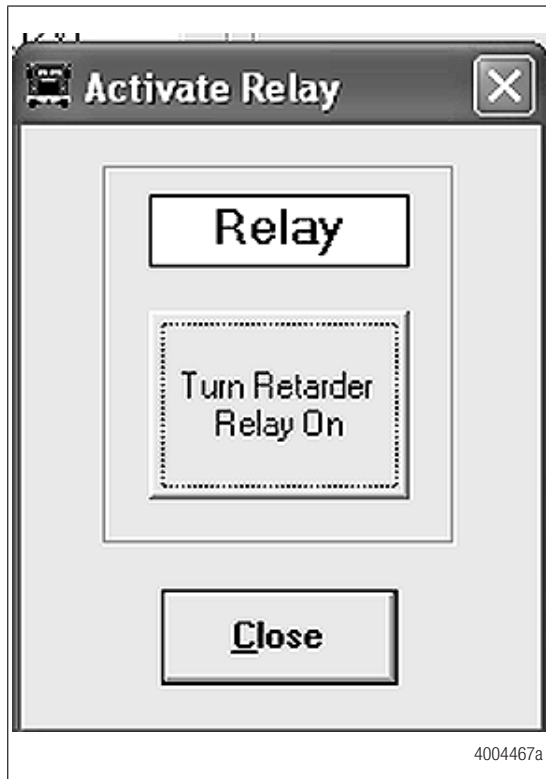

Figure 2.18

This screen allows you to turn the retarder relay on or off. This is helpful in verifying correct operation, installation and wiring of the unit under test. Select **Close** to exit this screen.

Engine Data Link

Select **Engine Data Link** to display the **Data Link** test screen. Figure 2.19.

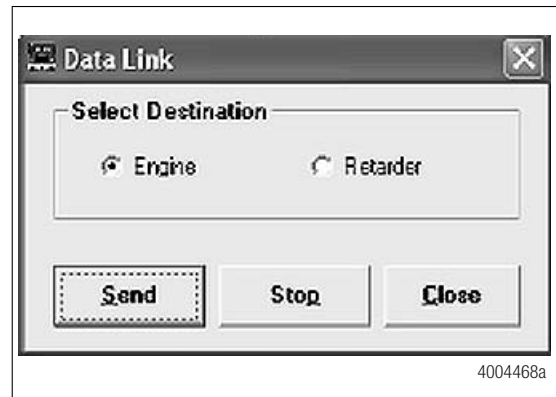

Figure 2.19

This screen allows you to send a “limit engine torque” command to the engine or a “disable retarder” command to the retarder.

Select the data link destination (engine or retarder), then select **Send** to test. Use the **Stop** button to end testing. Select **Close** to exit this screen.

Reset Memorized

This is an automatic default and cannot be de-selected. It indicates the ECU has memorized the installed retarder relay. Once the ECU has seen a retarder, it expects to see it every time the vehicle is powered up. Figure 2.20.

Because there are times when an ECU is moved to another vehicle — or during diagnostic testing — you may want the ECU to disregard this learned component. Use the **Reset Memorized** command for this purpose.

Select **Component Tests** from the Hydraulic ABS **Main Menu**. Then, select **Reset Memorized** from the pull-down menu to reset the **Learned Component** screen. Figure 2.21.

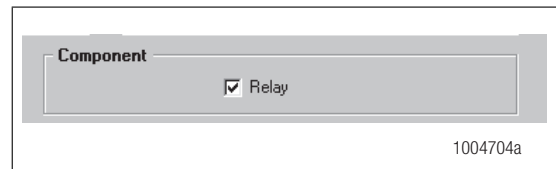

Figure 2.20

2 Troubleshooting and Testing

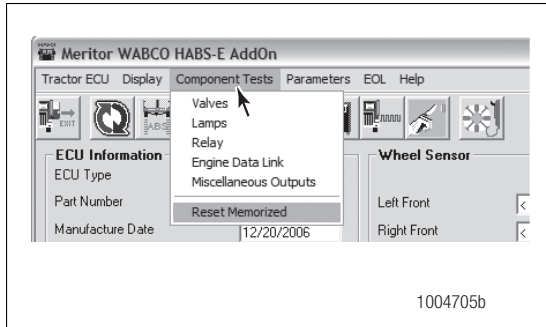

Figure 2.21

556

Standard Testing

Test Equipment: Volt-Ohm Meter (VOM)

Use of a VOM with automatic polarity sensing is recommended. This eliminates the concern of the polarity of the meter leads during voltage measurements.

System Requirements and Component Tests

Tire Size Range

For correct hydraulic ABS operation, front and rear tire sizes must be within 16% of each other.

Contact the Meritor WABCO Customer Support Center at 800-535-5560 if you plan a tire size difference greater than 8%.

Calculate the tire size with the following equation:

$$\% \text{ Difference} = (\text{RPM Steer}/\text{RPM Drive}) - 1 \times 100$$

RPM = tire revolutions per mile

⚠ CAUTION

When troubleshooting or testing the ABS system, do not damage the connector terminals. Damaged connector terminals may cause system malfunction.

Voltage Check

Voltage must be between 9.5 and 14 volts for the 12-volt hydraulic ABS to function correctly.

Check voltage as follows.

1. Turn ignition ON.
2. Check for the correct voltage.
 - Pins 16 to 18
 - Pins 17 to 19
 - Pins 1 to 6

Standard Component Testing

ABS Indicator Lamp

If the ABS indicator lamp does not come on after the ignition is turned on, or it comes on but does not go out after three seconds, check all ABS fuses or circuit breakers and replace if necessary. Check the wiring to the ABS diagnostic switch and the indicator lamp and repair or replace the wiring as required. When checking the indicator lamp, follow these steps:

1. Check voltage potential at the lamp socket.
2. Check continuity of the wires to the socket.
3. Replace the bulb.

NOTE: A complete wiring diagram for 4S/4M D Version hydraulic ABS appears in Figure 2.2 in this section.

ABS Blink Code Switch

When testing the ABS diagnostic switch, perform the following.

1. Check the resistance between the terminals while cycling the switch. A lack of continuity is an indication of a faulty switch.
2. Check the continuity of the wires to the switch:
 - Pins 21 and 6 on the 31-pin harness



2 Troubleshooting and Testing

Sensor Adjustment

On steering axles, the sensor is typically accessible on the in-board side of the steering knuckle.

On drive axles, the sensor is typically accessible on the in-board side of the rear axle spindle.

To adjust the sensor, push the sensor in until it contacts the tooth wheel.

- Do not pry or push sensors with sharp objects.
- Sensors will self-adjust during wheel rotation.

NOTE: No gap is allowable at installation. During normal operation, a gap not to exceed 0.04-inch is allowable.

Sensor Output Voltage Test

Sensor output voltage must be at least 0.2 volt AC at 30 rpm. Test the sensor output voltage as follows:

1. Turn ignition OFF.
2. Disconnect the ECU to measure voltage at the pins on the ECU connector. Refer to Table C.

WARNING

Park the vehicle on a level surface. Block the wheels to prevent the vehicle from moving. Support the vehicle with safety stands. Do not work under a vehicle supported only by jacks. Jacks can slip and fall over. Serious personal injury and damage to components can result.

3. Place blocks under the front and rear tires to stop the vehicle from moving.
4. Raise the vehicle off the ground. Place safety stands under the axle.
5. Rotate the wheel by hand at 30 rpm (1/2 revolution per second).
6. Measure the voltage at the pins indicated in Table C. Voltage tolerance is ≥ 0.2 volts alternating current (VAC).

Table C: Sensor Check Pins

Sensor	HABS E Version ECU
	31-Pin Harness
Left Front	24 and 29
Right Front	25 and 30
Left Rear	23 and 28
Right Rear	22 and 27

Sensor Resistance

The sensor circuit resistance must be between 900 and 2000 ohms. Measure resistance at the sensor connector, or at the pins on the ECU connector, as follows.

1. Turn ignition OFF.
2. To measure resistance at the pins on ECU connector, disconnect the ECU connector from the ECU.

To measure resistance at the sensor connector, disconnect the sensor from the sensor extension cable.

3. Measure output at the pins indicated in Table C.

If measurement is not between 900 and 2000 ohms, replace the sensor.

3 Component Replacement

Component Removal and Installation

Sensors

Sensor Lube Specification

Meritor WABCO specifications call for a sensor lubricant with the following characteristics.

Lube must be mineral oil-based and contain molydisulfide. It should have excellent anti-corrosion and adhesion characteristics and be capable of continuous function in a temperature range of -40° to 300°F (-40° to 150°C).

Wheel Speed Sensor Replacement — Front Axle

Removal

⚠ WARNING

To prevent serious eye injury, always wear safe eye protection when you perform vehicle maintenance or service.

Park the vehicle on a level surface. Block the wheels to prevent the vehicle from moving. Support the vehicle with safety stands. Do not work under a vehicle supported only by jacks. Jacks can slip and fall over. Serious personal injury and damage to components can result.

⚠ CAUTION

To avoid damage to the electrical system or HABS components, when welding on a HABS-equipped vehicle disconnect the power connector from the ECU.

1. Park the vehicle on a level surface. Apply the parking brakes. Block the rear tires to prevent the vehicle from moving.
If necessary, raise the front tires off the ground. Place safety stands under the axle.
2. Disconnect the fasteners that hold the sensor cable to other components.
3. Disconnect the sensor cable from the chassis harness.
4. Remove the sensor from the sensor holder. Twist and pull the sensor to remove it from the sensor bracket. **Do not pull on the cable.** Figure 3.1.

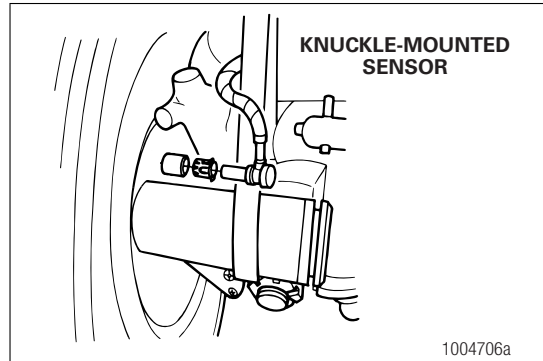

Figure 3.1

Installation

1. Connect the sensor cable to the chassis harness.
2. Install the fasteners used to hold the sensor cable in place.
3. Apply a Meritor WABCO-recommended lubricant to the sensor spring clip and sensor.
4. Install the sensor spring clip. Verify that the spring clip tabs are on the inboard side of the vehicle.
5. With the tabs on the inboard side, push the sensor spring clip into the bushing in the steering knuckle until the clip stops.
6. Push the sensor completely into the sensor spring clip until it contacts the tooth wheel.
7. Fasten the sensor cable every 12 inches. Correctly bundle and store any excess cable in the sub-frame. Figure 3.1.
8. Remove the blocks and safety stands.
9. Perform a voltage output check to ensure correct installation. Refer to Section 2.

Wheel Speed Sensor Replacement — Rear Axle

Removal

1. Apply the parking brake. Block the front tires to prevent vehicle movement.
2. Raise the rear tires off the ground. Place safety stands under the axle.
3. If the rear tire must be removed to gain access to the sensor, release the parking brake to release the brake shoe.
Remove the wheel and tire assembly from the axle.



3 Component Replacement

4. Remove the sensor from the mounting block. Use a twisting motion if necessary. **Do not pull on the cable.**
5. Disconnect the sensor cable from the chassis harness.
6. Remove the sensor cable from any cable clamps or clips.
7. Remove the sensor spring clip from the sensor bracket.

Installation

1. Connect the new sensor cable to the chassis harness.
2. Press the sensor spring clip into the sensor bracket, located on the rear axle, until it stops. Verify that the tabs are on the inboard side.
3. Apply a Meritor WABCO-recommended lubricant to the sensor.
4. Push the sensor completely into the spring clip until it contacts the tooth wheel.
5. Reattach the sensor cable to the cable clamps or clips.
6. Fasten the sensor cable every 12 inches. Correctly bundle and store excess cable in the sub-frame. Figure 3.2.

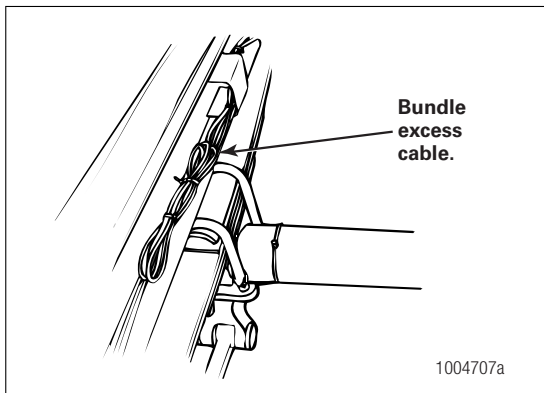

Figure 3.2

7. Replace the tire and remove the safety stands. Lower the vehicle and remove the blocks from the front tires.
8. Perform a voltage output check to ensure correct installation. Refer to Section 2.

Electronic Control Unit (ECU)

Removal

⚠ WARNING

To prevent serious eye injury, always wear safe eye protection when you perform vehicle maintenance or service.

⚠ CAUTION

Hydraulic brake fluid is a caustic substance. Contact with the hydraulic brake fluid can cause skin irritation. Do not let hydraulic brake fluid touch any painted surfaces, as it will remove the paint. Hydraulic brake fluid may also damage certain non-metal surfaces. Do not let fluid contact brake pads, shoes, rotors or discs.

NOTE: Do not open the ECU. Opening the ECU to gain access to the internal components will void the warranty.

NOTE: The following general guidelines are provided to facilitate the safe removal of the ECU module from the modulator assembly.



- It is not necessary to remove the entire modulator to replace the Electronic Control Unit (ECU).
 - When only the ECU is replaced, bleeding the system is not necessary.
1. Park the vehicle on a level surface. For vehicles with manual parking brakes, apply the parking brakes.
 2. Block the front and rear tires to prevent vehicle movement.
 3. Disconnect the battery.
 4. Use a clean rag to carefully wipe the surface of the modulator and the surrounding area.
 5. Open the latches on the 31-pin harness attached to the ECU. After the latch is released, remove the connectors from the ECU.
 6. Use a 4 mm Allen wrench to loosen and remove the four mounting screws that attach the ECU module to the modulator valve.
 7. Carefully remove the ECU by lifting straight out. To avoid damage, do not twist the ECU during removal. Determine the warranty status of the ECU. If the ECU is under warranty, return it to Meritor WABCO. If it is not under warranty, discard the used ECU.
 8. Use a clean rag to carefully clean the area around the valves formerly covered by the ECU.

3 Component Replacement

Installation

⚠ CAUTION

Excessive force in positioning the ECU onto the modulator will damage the ECU housing. Do not force the ECU into position. Use a gentle, even pressure when positioning the ECU.

1. Position the ECU onto the modulator valve. Apply gentle pressure to seat the ECU. Motor connectors must achieve full depth into the housing. The gap between the modulator and ECU must not exceed 0.08-inch (2 mm).
2. Use a 4 mm Allen wrench to tighten the four mounting screws that attach the ECU to the modulator. Tighten to 14 in-lb (1.5 N•m). Do not exceed this torque. The metal sleeves on the ECU housing must rest flat on the body of the modulator. 
3. When the ECU is correctly installed with the metal sleeves flat on the modulator, tighten the bolts to 21-30 in-lb (2.5-3.5 N•m). 

⚠ WARNING

Electrical connectors must be correctly installed with the latch pushed in to lock the connector. Failure to do so may allow the connectors to come loose or disconnect resulting in loss of ABS function.

4. Attach the 31-pin harness connector to the ECU.
5. Connect the battery.

Modulator Assembly

Removal

⚠ CAUTION

The modulator assembly contains hydraulic brake fluid, a caustic substance. Remove the valve carefully so that fluid does not leak and cause skin irritation or damage to components.

NOTE: If there is interference, the entire bracket and valve assembly can be removed.



1. Apply the parking brakes. Block the front and rear tires to prevent vehicle movement.
2. Place a container under the modulator assembly to catch leaking brake fluid.

3. Disconnect the electrical harness connectors from the modulator assembly.
4. Mark the six brake lines for ease of installation. Disconnect the lines from the modulator assembly.
5. Remove the three mounting capscrews and washers that attach the modulator assembly to the bracket.

NOTE: Whenever any hydraulic system fitting is loosened or disconnected, the entire system must be bled to remove any air that may have entered. Refer to "Brake Bleeding Procedures" in this section.

6. Remove the modulator assembly.
7. Use a 4 mm Allen wrench to loosen and remove the four mounting screws that attach the ECU module to the modulator valve.
8. Carefully remove the ECU by lifting straight out. To avoid damage, do not twist the ECU during removal.

Installation

1. Position the old ECU onto the new modulator valve. Apply gentle pressure to seat the ECU. Motor connectors must achieve full depth onto the housing. The gap between the modulator and the ECU must not exceed 0.08-inch (2 mm).
2. Use a 4 mm Allen wrench to tighten the four mounting screws that attach the ECU to the modulator. Tighten to 14 in-lb (1.5 N•m). Do not exceed this torque. The metal sleeves on the ECU housing must rest flat on the body of the modulator. 
3. When the ECU is correctly installed with the metal sleeves flat on the modulator, tighten the bolts to 21-30 in-lb (2.5-3.5 N•m). 
4. Position the modulator assembly in place on the vehicle. Figure 3.3.



3 Component Replacement

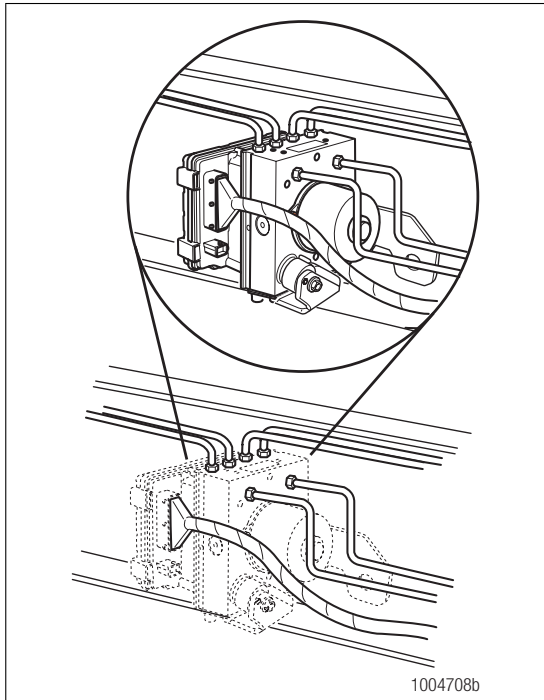



Figure 3.3

5. Tighten the three mounting nuts to 16 ft-lb (22 N•m). 
6. Connect the electrical harnesses to the modulator assembly.
7. Connect and tighten the brake line connections.
8. Bleed the brake system, per the following instructions.

Brake Bleeding Procedures

General

The following brake bleeding methods explain how to bleed the hydraulic ABS modulator assembly during installation, or in the event of air in the brake system. There are instructions for both pressure and manual bleeding procedures.

These instructions include the procedure for bleeding both the master cylinder and the brake system. In some cases, for example, if you are replacing only the modulator assembly, it may not be necessary to bleed the master cylinder. If you have any questions, please contact the Meritor Service Center at 800-535-5560.

NOTE: The modulator assembly must be handled with appropriate care and should not be exposed to excessive impact or compressed air at the hydraulic ports prior to assembly.

WARNING

Failure to bleed the system whenever any hydraulic system fitting is loosened or disconnected will allow air to remain in the system. This will prevent the hydraulic pressure in the brake system from rising enough to apply the brakes correctly. This will cause the stopping distance to increase and can result in serious personal injury.

Correctly discard hydraulic brake fluid that is removed from the brake system. Hydraulic brake fluid that is removed can be contaminated and can cause damage, loss of braking and serious personal injury.

Use only the type of hydraulic brake fluid specified by the equipment manufacturer. Do not use or mix different types of hydraulic brake fluid. The wrong hydraulic brake fluid will damage the rubber parts of the brake caliper and can cause damage, loss of braking and serious personal injury.

NOTE: Use DOT 3 or DOT 4 hydraulic brake fluid. Refer to the vehicle specifications to determine which fluid to use.

CAUTION

Hydraulic brake fluid is a caustic substance. Contact with hydraulic brake fluid can cause skin irritation. Do not let hydraulic brake fluid touch any painted surfaces, as it will remove the paint. Hydraulic brake fluid may also damage certain non-metal surfaces. Do not let fluid get on brake pads, shoes, rotors or discs.

Pressure Fill and Bleed

Pressure fill and bleed is the preferred method for bleeding the service brake system. It requires the use of a special pressure bleeder kit, consisting of a tank, pressure pump and valve, gauge, tubing and adapter. These kits are available from a number of manufacturers and include instructions for use. Figure 3.4.

3 Component Replacement

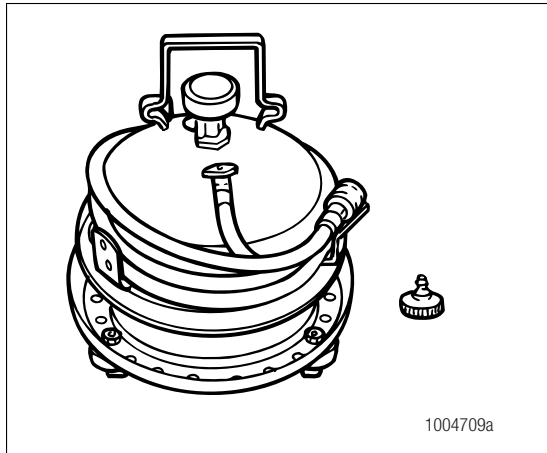

Figure 3.4

Pressure Fill and Bleed Procedure

CAUTION

Turn the ignition OFF for the entire bleed procedure. Do not energize the unit during the bleed procedure. Improper bleeding may result in system malfunction due to the presence of air in the closed hydraulic system.

1. Apply the parking brake and block the tires. Turn the ignition OFF and disconnect the battery terminals.
2. Fill the pressure bleeder with new DOT 3 or DOT 4 hydraulic brake fluid. Refer to the vehicle specifications to determine which fluid to use.
3. Follow the manufacturer's instructions to connect the pressure bleeder to the brake master cylinder reservoir.
4. Set the filling pressure to 20 to 30 psi (1.5 to 2.0 bar).
5. Turn on the bleed equipment until the fluid level in the reservoir reaches approximately 0.875-inches (20 mm).
6. Release pressure for three to five seconds. Apply pressure for five to 10 seconds.
7. Repeat Step 5 and Step 6 approximately 10 times. After releasing the pressure, air bubbles should rise up into the reservoir.

WARNING

Do not let the brake master cylinder fluid get below the minimum level during the bleeding operation. Keep the master cylinder reservoir filled with new DOT-approved brake fluid, as specified by the original equipment manufacturer. Failure to keep the brake reservoir level above minimum could result in more air entering the system, making it impossible to effectively bleed the system resulting in increased stopping distance.

8. Bleed the brake system:
 - Set the filling pressure to 20 to 30 psi (1.5 to 2.0 bar).
 - Place a wrench on the brake actuator bleeder fitting. Start with the farthest from the modulator, typically the right rear, then attach a length of clear plastic tubing to the bleeder fitting. Verify that the tube fits snugly.

NOTE: Both the tubing and container must be able to withstand the effects of hydraulic brake fluid. Tools used for bleeding the system should be brake fluid-safe.

9. Submerge the tubing in a container of clean hydraulic brake fluid. Figure 3.5.

Loosen the bleeder fitting until the fluid begins to flow (about 3/4 turn). Let the hydraulic fluid flow out of the fitting until it is free of air bubbles.

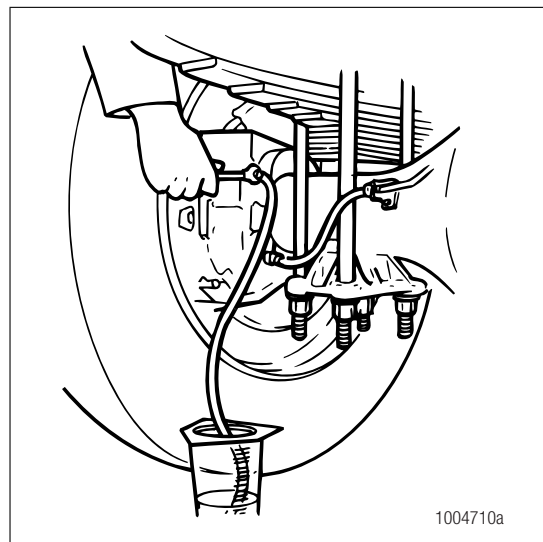

Figure 3.5



3 Component Replacement

10. Tighten firmly to secure the fitting.
11. Repeat Step 5 through Step 8 to bleed the remaining three brake actuators. Bleed in sequence of the longest to shortest circuit from the modulator assembly.
12. Turn off bleed equipment and remove pressure. Remove the bleed device and check the fluid level in the reservoir. Fill if required. Replace the reservoir cap and dispose of used brake fluid.
13. Remove the wheel blocks.

Manual Bleed Procedure

NOTE: The ignition must remain off for the entire bleed procedure; energizing the unit during bleeding must be impossible.

1. Apply the parking brake and block the tires. Turn the ignition OFF and disconnect the battery terminals.
2. Fill the reservoir with DOT 3 or DOT 4 hydraulic brake fluid. Refer to the vehicle specifications to determine which fluid to use.
3. Depress the brake pedal five times using the stroke between 1/3 travel and maximum travel in five seconds.
4. Release the pedal for five to 10 seconds. Air bubbles will rise into the reservoir while depressing and releasing the pedal.
5. Repeat Step 3 and Step 4 another three times, or until sufficient pedal resistance is felt.

WARNING

Do not let the brake master cylinder fluid get below the minimum level during the bleeding operation. Keep the master cylinder reservoir filled with new DOT-approved brake fluid as specified by the original equipment manufacturer. Failure to keep the brake reservoir level above minimum could result in more air entering the system, making it impossible to effectively bleed the system resulting in increased stopping distance.

6. Bleed the brake system. Place a wrench on the brake actuator bleeder fitting. Start with the farthest from the modulator, (typically the right rear), then attach a length of clear plastic tubing to the bleeder fitting. Verify that the tube fits snugly.

NOTE: Both the tubing and container must be able to withstand the effects of brake fluid. Tools used for bleeding the system should be brake fluid-safe.

7. Submerge the tubing in a container of clean brake fluid. Figure 3.5.
8. Depress the brake pedal 10 to 15 times, using the maximum available stroke.
9. Loosen the bleeder fitting until the fluid begins to flow (about 3/4 turn), while depressing the brake pedal through its maximum available stroke.
10. Tighten the fitting firmly prior to releasing the brake pedal.
11. Repeat Step 6 through Step 8 several times until the discharged fluid is free of air bubbles.
12. Repeat Step 3 through Step 9 to bleed the remaining three brake actuators. Bleed in sequence of the longest to the shortest circuit from the modulator.
13. Check the travel of the brake pedal. If a firm resistance is felt, the manual bleeding procedure is complete.
14. Check the fluid level in the reservoir and fill if required. Replace the reservoir cap and dispose of used brake fluid.
15. Remove the wheel blocks.

Meritor WABCO Vehicle Control Systems

2135 West Maple Road
Troy, MI 48084-7121
800-535-5560
meritorwabco.com

Copyright 2007
ArvinMeritor, Inc.

Printed in USA

Issued 09-07
Maintenance Manual MM-0677 (16579/22882)

MERITOR WABCO





MERITOR®

an *ArvinMeritor* brand

Issued 01-01

\$2.50

Four-Piston Quadraulic™ Disc Brake Caliper

Maintenance Manual MM-2075

565

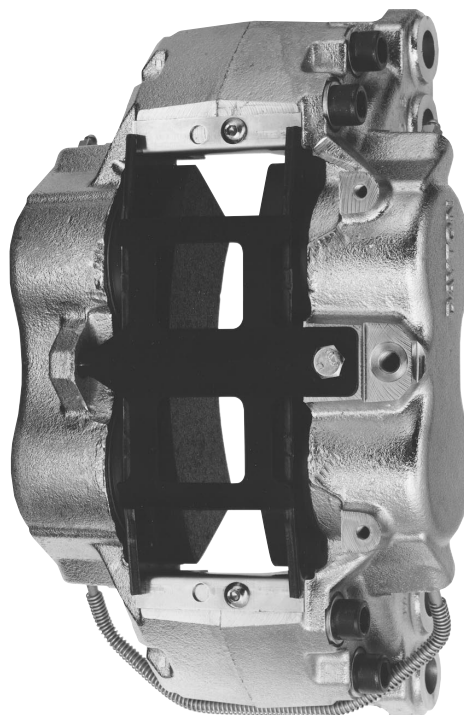



MERITOR®

Service Notes

Before You Begin

This manual provides maintenance and service procedures for Meritor's four-piston quadraulic disc brake calipers. Before you begin procedures:

1. Read and understand all instructions and procedures before you begin to service components.
2. Read and observe all Caution and Warning safety alerts that precede instructions or procedures you will perform. These alerts help to avoid damage to components, serious personal injury, or both.
3. Follow your company's maintenance and service, installation, and diagnostics guidelines.
4. Use special tools when required to help avoid serious personal injury and damage to components.

Access Information on ArvinMeritor's Web Site

Additional maintenance and service information for ArvinMeritor's commercial vehicle systems component lineup is also available at www.arvinmeritor.com.

To access information, click on Products & Services/Tech Library Icon/HVS Publications. The screen will display an index of publications by type.

Additional Information

Call ArvinMeritor's Customer Service Center at 800-535-5560 to order the following item.

- *Drivetrain Plus™ by ArvinMeritor Technical Electronic Library* on CD. Features product and service information on most Meritor, ZF Meritor and Meritor WABCO products. \$20. Order TP-9853.

Safety Alerts, Torque Symbol and Notes



 WARNING	A Warning alerts you to an instruction or procedure that you must follow exactly to avoid serious personal injury and damage to components.
 CAUTION	A Caution alerts you to an instruction or procedure that you must follow exactly to avoid damage to components and possible serious injury.
	A torque symbol alerts you to tighten fasteners to a specified torque value.
NOTE	A Note provides information or suggestions that help you correctly service a component.



Table of Contents

▲ Asbestos and Non-Asbestos Fibers Warnings	1
Section 1: Exploded Views	2
Section 2: Introduction	
Product Features	3
Four-Piston Quadraulic Disc Brake Caliper	
Caliper	
Support	
Hub/Rotor	4
Section 3: Disassembly	
Removal	5
Brake Pads	
Replace Brake Pads	
Brake Caliper	6
Support	7
Rotor	
Disassemble and Overhaul the Brake Caliper	
Section 4: Prepare Parts for Assembly	
Clean, Dry and Inspect Parts	10
Clean Parts	
Dry and Inspect Parts	
Apply Corrosion Protection	
Section 5: Assembly and Installation	
Assembly	11
Brake Caliper	
Installation	12
Rotor	
Caliper	
Brake Pads	13
Assemble the Support	14
Section 6: Inspection	
Inspect Parts	15
Caliper	
Caliper Mounting Plate	
Brake System Bleeding Procedure	
Section 7: Troubleshooting	
Brakes	16
Section 8: Torque Specifications	18



Asbestos and Non-Asbestos Fibers



ASBESTOS FIBERS WARNING

The following procedures for servicing brakes are recommended to reduce exposure to asbestos fiber dust, a cancer and lung disease hazard. Material Safety Data Sheets are available from ArvinMeritor.

Hazard Summary

Because some brake linings contain asbestos, workers who service brakes must understand the potential hazards of asbestos and precautions for reducing risks. Exposure to airborne asbestos dust can cause serious and possibly fatal diseases, including asbestosis (a chronic lung disease) and cancer, principally lung cancer and mesothelioma (a cancer of the lining of the chest or abdominal cavities). Some studies show that the risk of lung cancer among persons who smoke and who are exposed to asbestos is much greater than the risk for non-smokers. Symptoms of these diseases may not become apparent for 15, 20 or more years after the first exposure to asbestos. Accordingly, workers must use caution to avoid creating and breathing dust when servicing brakes. Specific recommended work practices for reducing exposure to asbestos dust follow. Consult your employer for more details.

Recommended Work Practices

1. **Separate Work Areas.** Whenever feasible, service brakes in a separate area away from other operations to reduce risks to unprotected persons. OSHA has set a maximum allowable level of exposure for asbestos of 0.1 f/cc as an 8-hour time-weighted average and 1.0 f/cc averaged over a 30-minute period. Scientists disagree, however, to what extent adherence to the maximum allowable exposure levels will eliminate the risk of disease that can result from inhaling asbestos dust. OSHA requires that the following sign be posted at the entrance to areas where exposures exceed either of the maximum allowable levels:

**DANGER: ASBESTOS
CANCER AND LUNG DISEASE HAZARD
AUTHORIZED PERSONNEL ONLY
RESPIRATORS AND PROTECTIVE CLOTHING
ARE REQUIRED IN THIS AREA.**

2. **Respiratory Protection.** Wear a respirator equipped with a high-efficiency (HEPA) filter approved by NIOSH or MSHA for use with asbestos at all times when servicing brakes, beginning with the removal of the wheels.
3. **Procedures for Servicing Brakes.**
 - a. Enclose the brake assembly within a negative pressure enclosure. The enclosure should be equipped with a HEPA vacuum and worker arm sleeves. With the enclosure in place, use the HEPA vacuum to loosen and vacuum residue from the brake parts.
 - b. As an alternative procedure, use a catch basin with water and a biodegradable, non-phosphate, water-based detergent to wash the brake drum or rotor and other brake parts. The solution should be applied with low pressure to prevent dust from becoming airborne. Allow the solution to flow between the brake drum and the brake support or the brake rotor and caliper. The wheel hub and brake assembly components should be thoroughly wetted to suppress dust before the brake shoes or brake pads are removed. Wipe the brake parts clean with a cloth.
 - c. If an enclosed vacuum system or brake washing equipment is not available, employers may adopt their own written procedures for servicing brakes, provided that the exposure levels associated with the employer's procedures do not exceed the levels associated with the enclosed vacuum system or brake washing equipment. Consult OSHA regulations for more details.
 - d. Wear a respirator equipped with a HEPA filter approved by NIOSH or MSHA for use with asbestos when grinding or machining brake linings. In addition, do such work in an area with a local exhaust ventilation system equipped with a HEPA filter.
 - e. **NEVER** use compressed air by itself, dry brushing, or a vacuum not equipped with a HEPA filter when cleaning brake parts or assemblies. **NEVER** use carcinogenic solvents, flammable solvents, or solvents that can damage brake components as wetting agents.
4. **Cleaning Work Areas.** Clean work areas with a vacuum equipped with a HEPA filter or by wet wiping. **NEVER** use compressed air or dry sweeping to clean work areas. When you empty vacuum cleaners and handle used rags, wear a respirator equipped with a HEPA filter approved by NIOSH or MSHA for use with asbestos. When you replace a HEPA filter, wet the filter with a fine mist of water and dispose of the used filter with care.
5. **Worker Clean-Up.** After servicing brakes, wash your hands before you eat, drink or smoke. Shower after work. Do not wear work clothes home. Use a vacuum equipped with a HEPA filter to vacuum work clothes after they are worn. Launder them separately. Do not shake or use compressed air to remove dust from work clothes.
6. **Waste Disposal.** Dispose of discarded linings, used rags, cloths and HEPA filters with care, such as in sealed plastic bags. Consult applicable EPA, state and local regulations on waste disposal.

Regulatory Guidance

References to OSHA, NIOSH, MSHA, and EPA, which are regulatory agencies in the United States, are made to provide further guidance to employers and workers employed within the United States. Employers and workers employed outside of the United States should consult the regulations that apply to them for further guidance.



NON-ASBESTOS FIBERS WARNING

The following procedures for servicing brakes are recommended to reduce exposure to non-asbestos fiber dust, a cancer and lung disease hazard. Material Safety Data Sheets are available from ArvinMeritor.

Hazard Summary

Most recently manufactured brake linings do not contain asbestos fibers. These brake linings may contain one or more of a variety of ingredients, including glass fibers, mineral wool, aramid fibers, ceramic fibers and silica that can present health risks if inhaled. Scientists disagree on the extent of the risks from exposure to these substances. Nonetheless, exposure to silica dust can cause silicosis, a non-cancerous lung disease. Silicosis gradually reduces lung capacity and efficiency and can result in serious breathing difficulty. Some scientists believe other types of non-asbestos fibers, when inhaled, can cause similar diseases of the lung. In addition, silica dust and ceramic fiber dust are known to the State of California to cause lung cancer. U.S. and international agencies have also determined that dust from mineral wool, ceramic fibers and silica are potential causes of cancer.

Accordingly, workers must use caution to avoid creating and breathing dust when servicing brakes. Specific recommended work practices for reducing exposure to non-asbestos dust follow. Consult your employer for more details.

Recommended Work Practices

1. **Separate Work Areas.** Whenever feasible, service brakes in a separate area away from other operations to reduce risks to unprotected persons.
2. **Respiratory Protection.** OSHA has set a maximum allowable level of exposure for silica of 0.1 mg/m³ as an 8-hour time-weighted average. Some manufacturers of non-asbestos brake linings recommend that exposures to other ingredients found in non-asbestos brake linings be kept below 1.0 f/cc as an 8-hour time-weighted average. Scientists disagree, however, to what extent adherence to these maximum allowable exposure levels will eliminate the risk of disease that can result from inhaling non-asbestos dust. Therefore, wear respiratory protection at all times during brake servicing, beginning with the removal of the wheels. Wear a respirator equipped with a high-efficiency (HEPA) filter approved by NIOSH or MSHA, if the exposure levels may exceed OSHA or manufacturers' recommended maximum levels. Even when exposures are expected to be within the maximum allowable levels, wearing such a respirator at all times during brake servicing will help minimize exposure.
3. **Procedures for Servicing Brakes.**
 - a. Enclose the brake assembly within a negative pressure enclosure. The enclosure should be equipped with a HEPA vacuum and worker arm sleeves. With the enclosure in place, use the HEPA vacuum to loosen and vacuum residue from the brake parts.
 - b. As an alternative procedure, use a catch basin with water and a biodegradable, non-phosphate, water-based detergent to wash the brake drum or rotor and other brake parts. The solution should be applied with low pressure to prevent dust from becoming airborne. Allow the solution to flow between the brake drum and the brake support or the brake rotor and caliper. The wheel hub and brake assembly components should be thoroughly wetted to suppress dust before the brake shoes or brake pads are removed. Wipe the brake parts clean with a cloth.
 - c. If an enclosed vacuum system or brake washing equipment is not available, carefully clean the brake parts in the open air. Wet the parts with a solution applied with a pump-spray bottle that creates a fine mist. Use a solution containing water, and, if available, a biodegradable, non-phosphate, water-based detergent. The wheel hub and brake assembly components should be thoroughly wetted to suppress dust before the brake shoes or brake pads are removed. Wipe the brake parts clean with a cloth.
 - d. Wear a respirator equipped with a HEPA filter approved by NIOSH or MSHA when grinding or machining brake linings. In addition, do such work in an area with a local exhaust ventilation system equipped with a HEPA filter.
 - e. **NEVER** use compressed air by itself, dry brushing, or a vacuum not equipped with a HEPA filter when cleaning brake parts or assemblies. **NEVER** use carcinogenic solvents, flammable solvents, or solvents that can damage brake components as wetting agents.
4. **Cleaning Work Areas.** Clean work areas with a vacuum equipped with a HEPA filter or by wet wiping. **NEVER** use compressed air or dry sweeping to clean work areas. When you empty vacuum cleaners and handle used rags, wear a respirator equipped with a HEPA filter approved by NIOSH or MSHA, to minimize exposure. When you replace a HEPA filter, wet the filter with a fine mist of water and dispose of the used filter with care.
5. **Worker Clean-Up.** After servicing brakes, wash your hands before you eat, drink or smoke. Shower after work. Do not wear work clothes home. Use a vacuum equipped with a HEPA filter to vacuum work clothes after they are worn. Launder them separately. Do not shake or use compressed air to remove dust from work clothes.
6. **Waste Disposal.** Dispose of discarded linings, used rags, cloths and HEPA filters with care, such as in sealed plastic bags. Consult applicable EPA, state and local regulations on waste disposal.

Regulatory Guidance

References to OSHA, NIOSH, MSHA, and EPA, which are regulatory agencies in the United States, are made to provide further guidance to employers and workers employed within the United States. Employers and workers employed outside of the United States should consult the regulations that apply to them for further guidance.



Section 1 Exploded Views

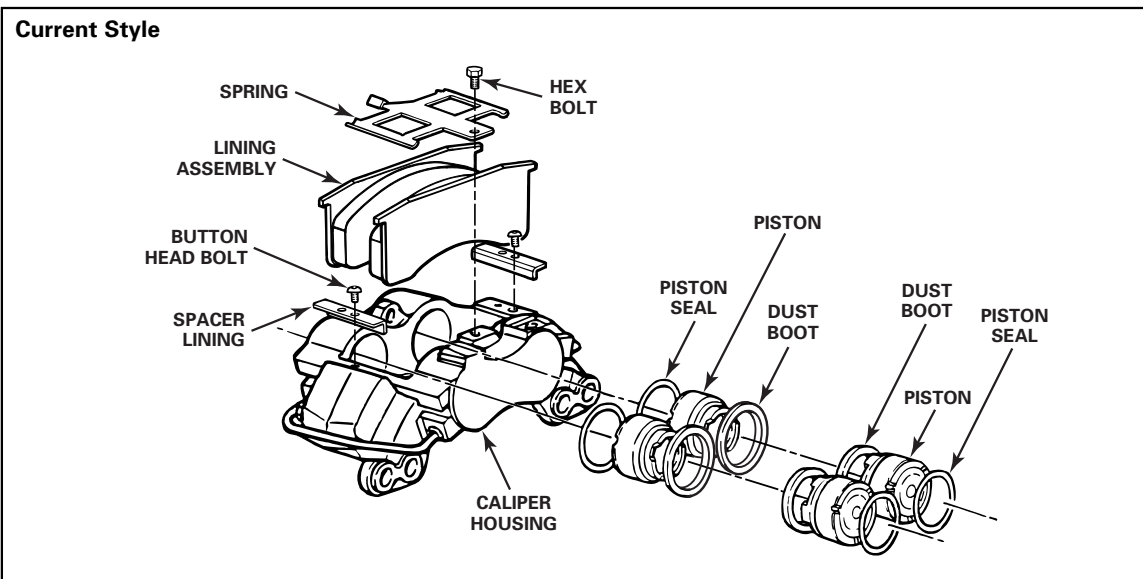
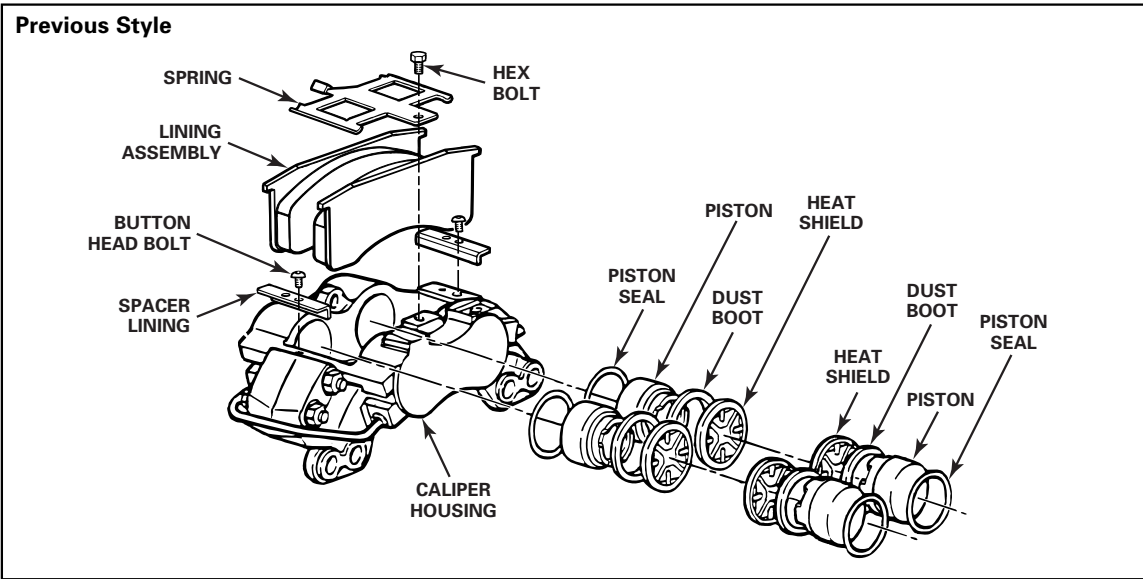



Section 2 Introduction

Product Features

Four-Piston Quadraulic Disc Brake Caliper

Meritor's quadraulic disc brakes have a four-piston, fixed-mount caliper design for use on both front and rear drive axles. An installation includes four major components – the caliper assembly, support assembly, hub/rotor assembly and the attaching hardware.

The inboard pistons apply the inboard pads and the outboard pistons apply the outboard pads. Two sizes of calipers are used, 2.520-inch (64 mm) and 2.756-inch (70 mm).

Features of the caliper include:

- Designed for hydraulic brake systems.
- Hard-mounted to the anchor plate to eliminate caliper and anchor plate replacement.
- Designed with hardened stainless steel mounting surfaces, high temperature piston boot compound, sealed bleeder screws and full-coverage zinc plating.
- Compatible with anti-lock braking systems (ABS) and existing hydraulic systems.
- Helps to increase lining life.
- Can be adapted to fit most vehicles with a hydraulic system that supplies to 1,800 psi (12,402 kPa).
- Available in 33,000 lbs maximum GVWR (4 x 70 mm) and maximum 24,000 lbs GVWR (4 x 64 mm).

Current Style	Previous Style
Metric caliper bolts	SAE caliper bolts
Caliper housing halves held together by bolts in blind holes in the bridge area.	Caliper housing halves held together by bolts and nuts in the bridge area.
Integral piston/heat shield	Separate piston and heat shield
Phenolic piston	Metal piston

Caliper

- The caliper assembly consists of two halves assembled with four bolts and washers.
- It includes four hydraulic piston bores, two brake pads, two stainless steel lining rail covers installed with button head bolts, a pad retainer spring and bolt, bleeder screw and crossover tube.
- The piston bores contain the pistons, piston seals and piston boots.
- The crossover tubes connect the two halves of the caliper piston to supply brake fluid to the outboard pistons.

How to Identify the Caliper

Check for an assembly number on the side of the caliper.

Support

The support assembly includes the ABS sensor bracket attached with two screws. It also has provisions to mount an optional splash shield to protect the rotor and brake assembly from road contamination. When the ABS system is not used or the sensor is mounted through the axle flange, the supports are not equipped with the sensor bracket.

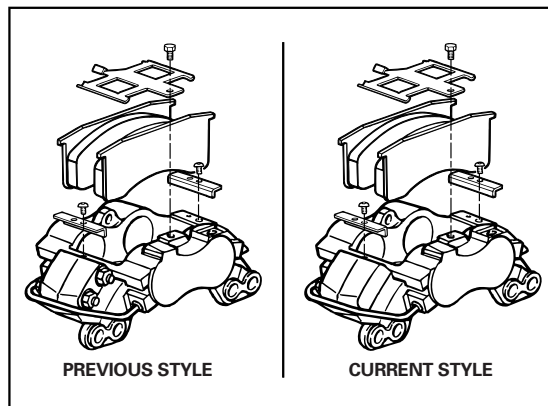



Section 2 Introduction



Hub/Rotor

- The hub and rotor assemblies consist of a hub and rotor, fitted with bearing cups and wheel attachment studs.
- There are two types of rotors used — a U-shaped rotor and a hat-shaped rotor.
- Some rotors are equipped with a cast-in ABS speed sensor tooth wheel, typically with 100 slots. Some rotors have separate ABS speed sensor tooth wheels attached to the rotor with bolts.
- Front hub/rotor assemblies can have various ABS speed sensor tooth wheels such as: a separate ring mounted to the inboard end of the hub, ABS teeth integral to the rotor, or a separate ABS ring attached to the rotor by bolts.
- There are various hub configurations offered to accept the 19.5-inch (495.3 mm) eight-hole wheels, as well as 22.5-inch (571.5 mm) 10-hole wheels with the hub piloted or stud piloted system.



Section 3 Disassembly

WARNING

To prevent serious personal injury, always wear safe eye protection when you perform vehicle maintenance or service.

Removal

Brake Pads

1. Visually inspect all brake pads. Replace pads when the remaining lining reaches 1/8-inch (3.175 mm) thickness.
 - **If you replace pads:** Replace all disc brake pads at the same time to maintain original brake balance.
 - **If a complete vehicle pad replacement is not necessary or desirable:** Replace the pads on both wheel ends on the same axle.

Replace Brake Pads

1. Raise and support the vehicle.
2. Remove the wheel and tire assembly according to manufacturer's recommendation.
3. Remove the master cylinder reservoir filler cap. Check the brake fluid level in the reservoir. If necessary, remove fluid to keep the reservoir from overflowing when compressing pistons into the caliper.
4. Remove the pad retainer spring bolt. **Figure 3.1.**
5. Compress the caliper pistons. **Figure 3.2.**
6. Remove the brake pads. **Figure 3.3.**

Figure 3.1

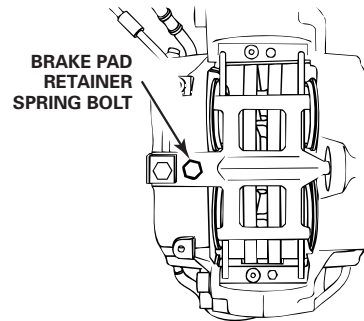

Figure 3.2

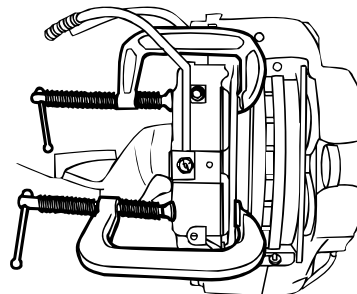
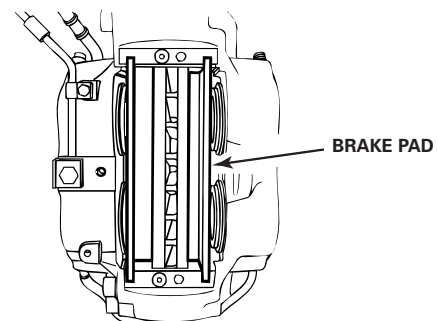

Figure 3.3





Section 3 Disassembly

MERITOR®

Brake Caliper

⚠ WARNING

Park the vehicle on a level surface. Block the wheels to prevent the vehicle from moving. Support the vehicle with safety stands. Do not work under a vehicle supported only by jacks. Jacks can slip and fall over. Serious personal injury can result.

1. Raise and support the vehicle.
2. Remove the tire and wheel assembly according to manufacturer's instructions.
3. Remove the brake hose hold down clamp bolt, if equipped. **Figure 3.4.**
4. Remove the brake hose/tube from the caliper. **Figure 3.5.**
5. Remove four caliper-to-support assembly bolts. **Figure 3.6. Do not disassemble the four bolts joining the two halves of the caliper.**

Figure 3.4

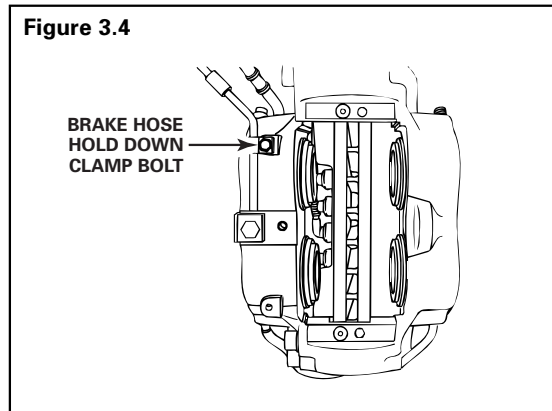

Figure 3.5

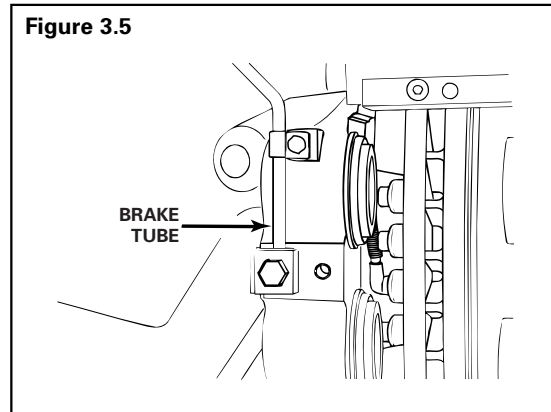
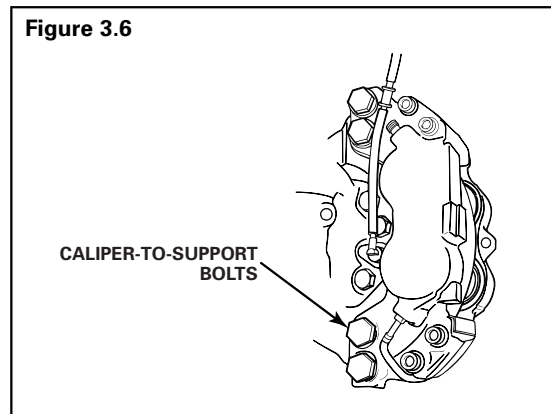

Figure 3.6





Section 3 Disassembly

Support

1. Remove the caliper from vehicle as described in Brake Caliper in this section.
2. Remove the splash shield if installed from the support.
3. Remove the hub and rotor assembly according to vehicle manufacturer's recommended service procedure.
4. Remove the ABS sensor.
5. Remove the support-to-axle mounting bolts. **Figure 3.7.**

Figure 3.7

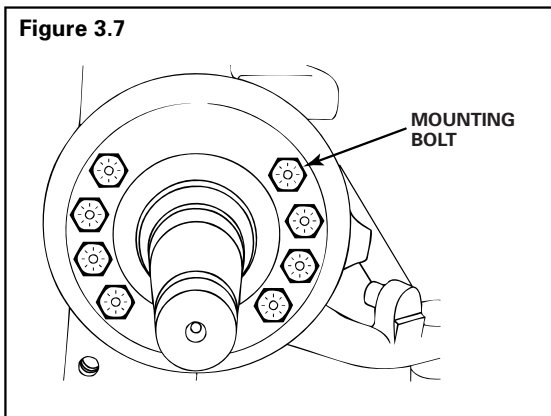

Rotor

NOTE: The thickness of the resurfaced rotor must exceed the minimum thickness dimension stamped or cast into the rotor. Replace if necessary.

1. Check the rotor while assembled to the hub or spoke wheel and mounted on the axle spindle. The lateral runout of the rotor friction surfaces should not exceed 0.015-inches (0.381 mm) total indicator reading (TIR). The thickness variation of the rotor should not exceed 0.0012-inches (0.0300 mm).
 - **If the lateral runout and/or the thickness variation exceed the above values:**
Resurface or replace the rotor.
2. Remove the caliper. Refer to Brake Caliper in this section.

3. Remove the hub/spoke wheel and rotor assembly from the axle according to vehicle manufacturer's recommendation.
4. Remove the hub-to-rotor attachment fasteners (hat-shaped rotor). For the U-shaped rotor, remove the studs holding the hub and rotor.

Disassemble and Overhaul the Brake Caliper

1. Remove the brake caliper. Refer to Brake Caliper in this section.
2. Drain all fluid from the caliper.
3. Push all four pistons to the bottom of their bores.
4. Remove the piston boots by prying the metal ring portion of the boot out of the bore with a screwdriver. Use care to avoid damage to the piston or bore. Discard the boots.

NOTE: The C-clamp must be between the pistons on the opposite side so they may move to the wood block without striking the C-clamp. Cover pistons with shop rag to prevent brake fluid spray.

5. Place a block of wood (7-5/8 x 3-1/2 x 2-9/16-inches thick) between the caliper pistons. **Figure 3.8.** Use a C-clamp to hold the block of wood against the pistons on one side of the caliper.

Figure 3.8

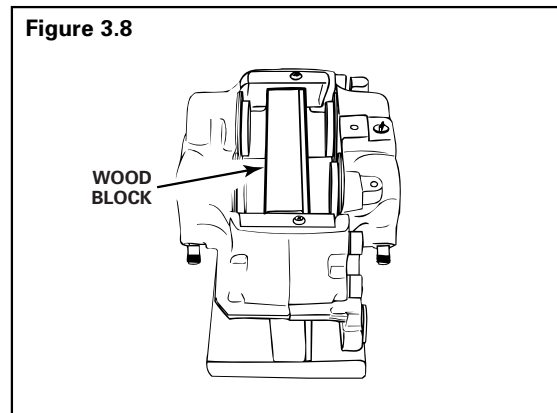



Section 3 Disassembly

MERITOR®

! WARNING

When you use compressed air to remove the pistons from the caliper bore, do not place your hands or fingers near the bore to catch or protect the pistons. Serious personal injury can result.

! CAUTION

When you remove the pistons from the caliper bore, only direct enough compressed air into the caliper brake fluid inlet to ease the pistons out of the bore. Do not exceed 25 psi (172 kPa). Damage to components will result.

6. Apply low air pressure (no more than 25 psi [172 kPa]) to the fluid port in the caliper to move the caliper pistons out to the wood block. **Figure 3.9.**
 7. With the pistons in contact with the wood block, there will be a small amount of seal engagement remaining. Remove the C-clamp and the wood block. The pistons may now be removed by hand.
 8. To remove the pistons from the other side of the caliper, place the block of wood now over the empty bores (from where the pistons have been removed) with a thick sheet of rubber (3/8-inch) between the wood and the caliper bores.
- NOTE:** Use the C-clamp to hold the block of wood in position against the empty bores. The C-clamp must be between the pistons on the opposite side so they may move out to the wood block without striking the C-clamp. Cover pistons with a shop rag to prevent brake fluid spray.
9. Apply low air pressure (no more than 25 psi [172 kPa]) to the fluid port in the caliper to move the caliper pistons out to the wood block.
 10. With the pistons in contact with the wood block, there will be a small amount of seal engagement remaining. Remove the C-clamp and the wood block. The pistons may now be removed by hand. **Figure 3.10.**

Figure 3.9

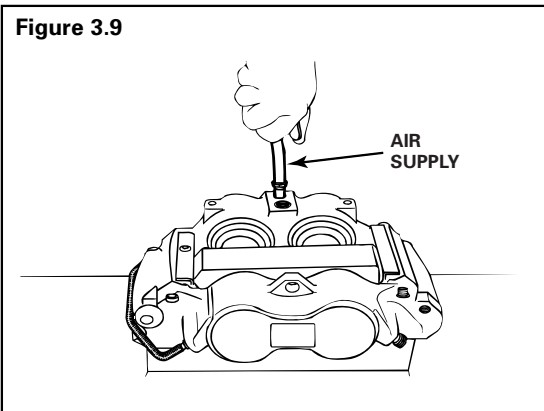
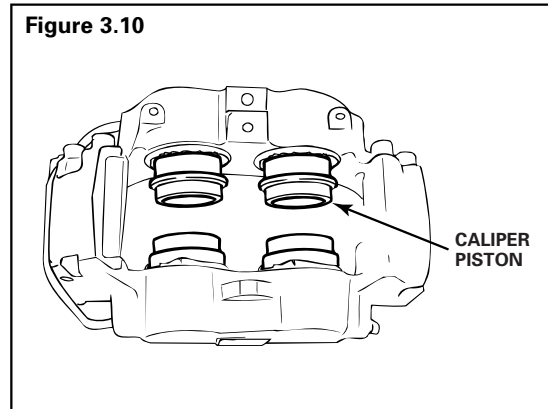

Figure 3.10





Section 3 Disassembly

11. Remove the piston seals with a non-metallic device and discard them. **Figure 3.11.** Do not nick, scratch or otherwise scar piston bores or seal grooves.

NOTE: Do not hone the caliper bores. Pistons are not available for honed caliper bores. If the caliper bores are excessively scored or corroded, install a new caliper.

Figure 3.11

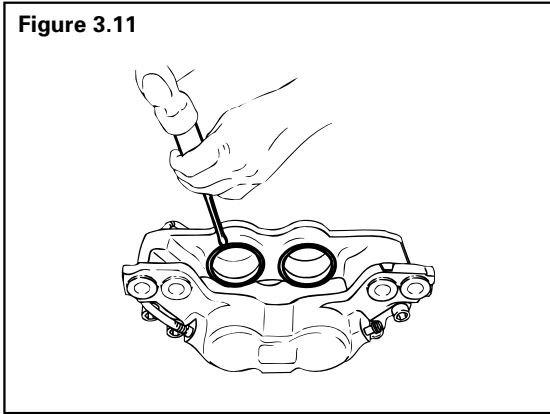



Section 4 Prepare Parts for Assembly



WARNING

To prevent serious eye injury, always wear safe eye protection when you perform vehicle maintenance or service.

Solvent cleaners can be flammable, poisonous and cause burns. Examples of solvent cleaners are carbon tetrachloride, emulsion-type cleaners and petroleum-based cleaners. To avoid serious personal injury when you use solvent cleaners, you must carefully follow the manufacturer's instructions and these procedures:

- *Wear safe eye protection.*
- *Wear clothing that protects your skin.*
- *Work in a well-ventilated area.*
- *Do not use gasoline or solvents that contain gasoline. Gasoline can explode.*
- *You must use hot solution tanks or alkaline solutions correctly. Carefully follow the manufacturer's instructions.*

Clean, Dry and Inspect Parts

Clean Parts

For Ground or Polished Metal Parts

CAUTION

Do not use hot solution tanks or water and alkaline solutions to clean ground or polished parts. Damage to parts will result.

Use a cleaning solvent or kerosene or diesel fuel to clean ground or polished metal parts or surfaces.

For Rough Metal Parts

Use a cleaning solvent or a weak alkaline solution in a hot solution tank to clean rough metal parts. If you use a hot solution tank, follow the instructions below.

1. Leave the rough parts in the tank until they are completely cleaned and heated.
2. Remove the rough parts from the tank.
3. Wash the parts with water until you remove the alkaline solution.

Dry and Inspect Parts

1. Use soft, clean paper or cloth rags or compressed air to completely dry parts immediately after you clean them.
2. Carefully inspect all parts for wear or damage before you assemble them.
3. Repair or replace worn or damaged parts.

Apply Corrosion Protection

1. Apply a thin layer of brake grease to cleaned, dried parts. Be careful that you do not apply the grease to the linings or rotor.
2. If you will store the parts, apply a special material, which prevents corrosion and rust, to all surfaces. Store parts inside special paper or other material that prevents rust and corrosion.



Section 5 Assembly and Installation

WARNING

To prevent serious eye injury, always wear safe eye protection when you perform vehicle maintenance or service.

Assembly

Brake Caliper

NOTE: When using compressed air, use air lines that are completely free of oil and moisture. All brake parts must be clean and completely dried of cleaning fluid. Use ONLY ArvinMeritor replacement parts to ensure proper caliper performance.

1. Clean caliper, caliper piston bores and fluid ports with solvent. Use compressed air to clean out and dry grooves and passages.
2. Dip new piston seals in new, clean DOT 3 hydraulic brake fluid and install in piston seal groove in caliper piston bores. Make sure that they are properly seated. Apply a thin film of silicon grease or brake fluid to the caliper bore seal land between the piston boot and seal groove. Apply the grease or brake fluid around the entire circumference of the caliper bore. **Figure 5.1.**
3. Apply DOT 3 hydraulic brake fluid to the outside of the caliper pistons and install them in caliper bores, making sure that they are square to the bore. **Figure 5.2.**
4. Be careful not to cock the caliper pistons and press them into the bores. **Figure 5.3.**

Figure 5.1

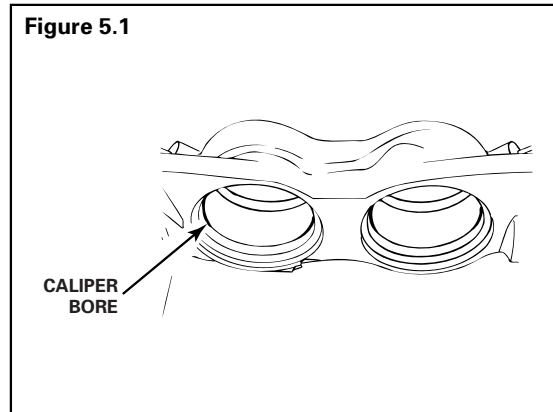

Figure 5.2

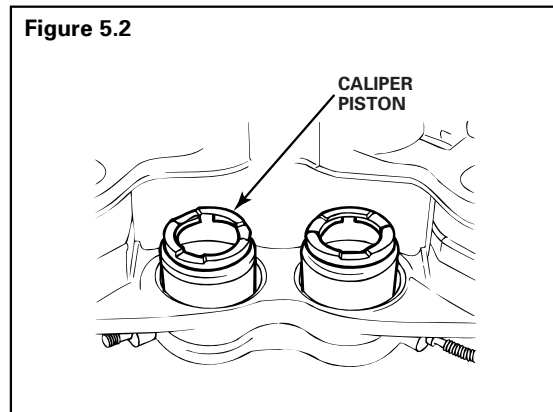
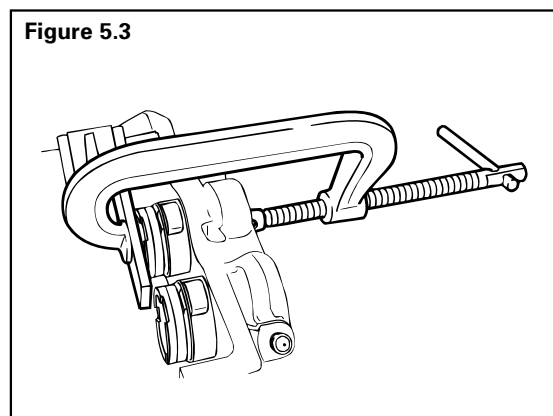

Figure 5.3





Section 5 Assembly and Installation

MERITOR®

5. Install the piston boots over the projecting ends of the pistons and press the ring side of the boots into the boot bore. **Figure 5.4.** An old bearing cup equal to the boot ring size helps install the boots. Make sure the piston boot bead is seated back against the shoulder of the projecting end of the piston. Boots for the 64 mm and 70 mm pistons are color-coded.
6. If required, replace the two stainless steel wear rails by removing the button head bolts.

NOTE: Inspect the caliper prior to reinstalling it onto the support. Pistons must be fully retracted into the caliper. Piston boots must be fully seated in the caliper boot grooves.

Figure 5.4

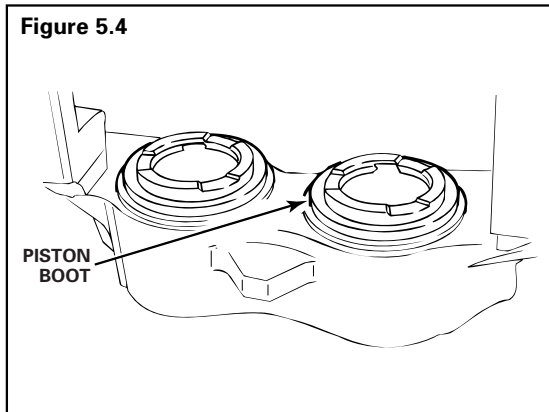

Installation

Rotor

NOTE: Do not resurface a new replacement rotor.

1. To install, reverse the removal processes, making sure that the mating surfaces of the hub or spoke wheel and rotor are clean and free of rust build-up.
2. Check the rotor for lateral runout. If the lateral runout exceeds 0.015-inches (0.381 mm), the rotor may be rotated to a different mounting hole position on the hub or spoke wheel to reduce the value.

Caliper

1. Inspect the caliper for leakage, damage or defects to piston seals or pistons. If leakage, damage or defect is found, caliper disassembly may be required. **Figure 5.5.**
2. To install, reverse the removal process. **Figures 5.6 and 5.7.**
3. Bleed the brake system and road test the vehicle.

Figure 5.5

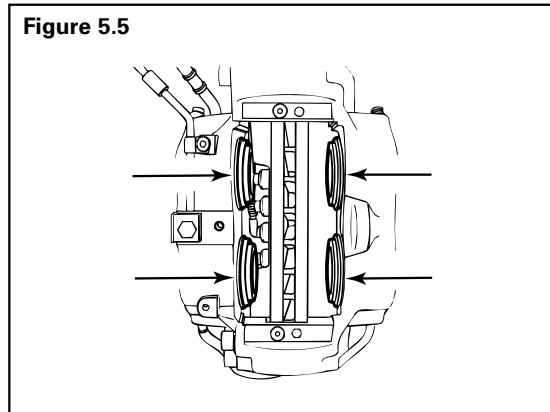



Section 5 Assembly and Installation

Figure 5.6

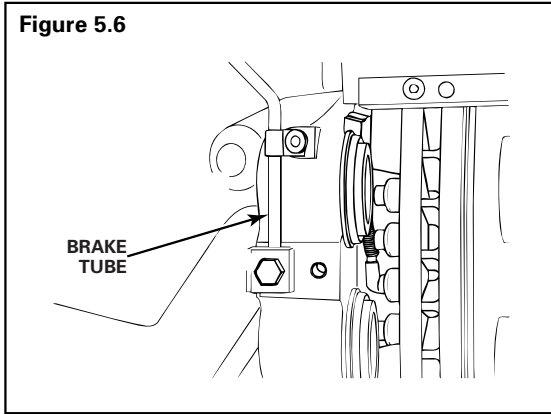

NOTE: The inboard and outboard brake pads are identical, except when they are equipped with a mechanical wear sensor.

4. Install the brake pads. Ensure that the friction surface is against the rotor. Install the pad retainer spring and tighten the bolt to 30 lb-ft (40 N•m) of torque. **Figure 5.8.**

NOTE: Brake pad clearance adjustment is automatic.

5. Fill the master cylinder reservoir with new, clean, high-performance DOT 3 brake fluid or equivalent. Make several brake applications to move the brake pistons and linings out into contact with the brake rotors.
6. Recheck master cylinder reservoir and top off as necessary to manufacturer's recommended level.
7. Bleed the brake system.
8. Install the tire and wheel assembly according to the manufacturer's instructions.
9. Lower the vehicle and road test for correct operation.

Figure 5.7

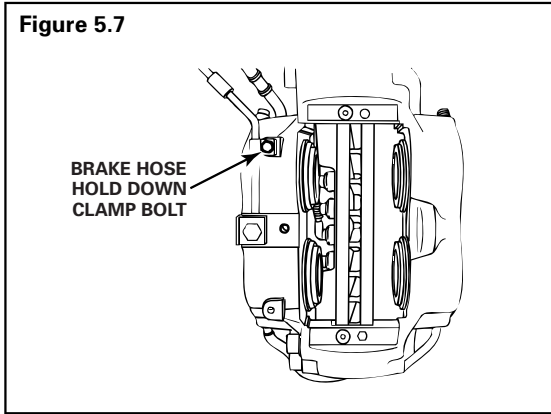

Brake Pads

1. Inspect the rotor for scoring, warping, cracks, bluing, heat spots or other damage or defects and minimum thickness. Repair or replace if necessary.
2. Inspect the disc brake calipers for leakage, damage or defects to piston boots, seals or pistons. Replace or repair the parts as required.
3. Clean and inspect the lining rail covers. If they are worn, they must be replaced.

Figure 5.8

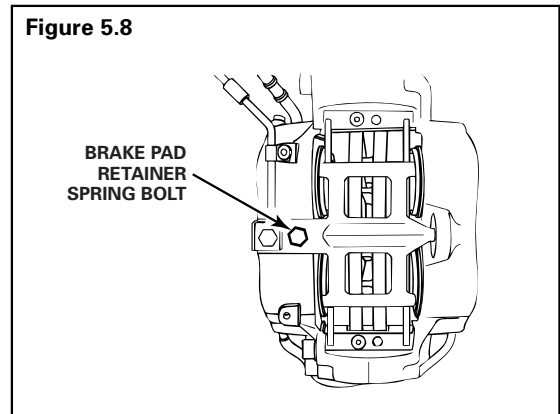





Section 5 Assembly and Installation

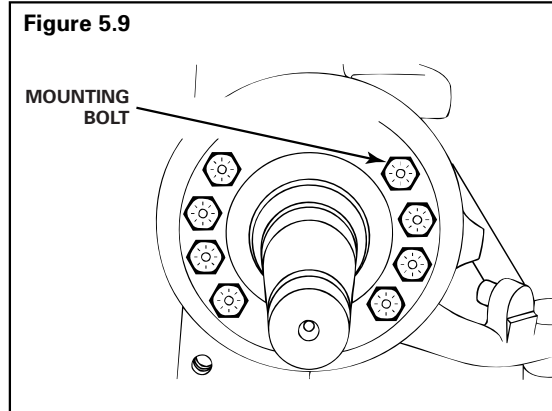

Assemble the Support

1. Install the support mounting bolts. Tighten the bolts to the specified torque. Refer to Section 8.
Figure 5.9. 



2. Install the ABS sensor. Tighten the bolt to 8 lb-ft (11 N•m). 
3. Install the hub and rotor assembly according to vehicle manufacturer's recommended service procedure.
4. Install the splash shield, if equipped.
5. Install the caliper as described in Caliper in this section.



⚠ WARNING

To prevent serious eye injury, always wear safe eye protection when you perform vehicle maintenance or service.

Inspect Parts

Caliper

1. Clean the area around the brake hose. Use brake parts cleaner.
2. Inspect the heat shields (previous style only) for wear and damage. Replace worn or damaged shields.
3. Inspect the caliper lining spacers for wear and damage. Replace worn or damaged spacers.
4. Inspect the housing for cracks or damage. Replace a cracked or damaged housing.

⚠ CAUTION

The OUTSIDE diameter of the piston is the caliper's primary sealing surface and is manufactured to very close tolerances. Replace a piston if the OUTSIDE diameter is damaged. Do not refinish or use abrasives, including an emery cloth, on the piston. Damage to components can result.

5. Inspect the OUTSIDE diameter of the pistons for scoring, nicks, corrosion, wear and damage.
 - **If any of these conditions are evident:** Replace the pistons. Do not refinish or use abrasives.
6. Inspect the caliper bore for scoring, nicks, corrosion, wear and damage.
 - **If any of these conditions are evident:** Replace the caliper.

⚠ CAUTION

Use a crocus cloth to remove minor stains and corrosion from the caliper bore. Do not use abrasives, including an emery cloth. If you cannot remove minor stains and corrosion, replace the caliper bore to avoid damage to components.

7. Inspect the caliper bore for minor stains and corrosion.



- **If these conditions are evident:** Use a crocus cloth to remove stains or corrosion. Clean the caliper bore after using a crocus cloth. Do not use abrasives, including an emery cloth.
- **If you cannot remove stains and corrosion from the caliper bore:** Replace the caliper.

Caliper Mounting Plate

1. Inspect caliper mounting plate area for rust, corrosion. Replace a damaged or worn mounting plate.
2. Use a wire brush to clean the caliper mounting area.
3. Inspect the mounting plate for cracks or elongated bolt holes.
 - **If these conditions are evident:** Replace the mounting plate.

Brake System Bleeding Procedure

Refer to manufacturer's service information for ABS bleeding instructions.

1. Check the master cylinder reservoir and fill, if necessary, with DOT 3 or DOT 4 brake fluid.
2. Bleed brakes in the following order: right rear, left rear, right front and left front.
3. Each four-piston caliper is equipped with two bleeder screws. Loosen the inner bleeder screw (which is always on the top) and purge the air. Tighten it loosely.
4. Open the outer bleeder screw and purge the air and tighten the bleeder screw to 9-12 lb-ft (12.2-16.3 N•m). 
5. Now again open the inner bleeder screw and purge the air and tighten the bleeder screw to 9-12 lb-ft (12.2-16.3 N•m). 
6. Repeat this procedure for all other brakes in the sequence specified in Step 2.
7. Test brakes prior to returning vehicle to service. A firm pedal should be felt during brake application.



Section 7 Troubleshooting



Brakes

Conditions	Possible Causes	Correction
Excessive Pedal Effort	Pads worn below minimum thickness	Install new pads.
	Faded, overheated condition, glazed pads, "blued" or heat-checked rotors	Replace the rotor and/or reface pads if sufficient lining remains.
	Grease, oil and/or brake fluid on linings	Install new pads in axle sets.
	Seized or frozen pistons	Disassemble calipers and free pistons, or replace caliper.
Pedal Pulsation (Brake Roughness or Chatter)	Excessive lateral runout of brake rotor	Check with dial indicator. Install new rotor if runout exceeds the maximum specified.
	Excessive out-of-parallelism of brake rotor	Check the parallelism (rotor thickness variation) with micrometer and resurface the rotor, or install new rotor if the parallelism exceeds the maximum allowed.
	Loose or worn steering or suspension parts	Replace parts and realign.
	Excessive front bearing clearance	Readjust the bearing to specifications.
Vehicle Pulls to One Side	Brake fluid, oil and/or grease on linings	Install new pads in axle sets.
	Unmatched linings, uneven lining wear, distorted pads	Install new pads in axle sets.
	Rough rotor surfaces on one rotor	Resurface or replace rotor in axle sets.
	Seized or frozen pistons	Disassemble caliper and repair or replace.
	Loose caliper mounting bolts	Tighten to specifications.
	Uneven tire pressure, tread wear or size, right to left	Equalize to recommended pressures. Install correct size tires with good tread.
	Excessive rotor parallelism or runout	Resurface or replace rotor.
	Restricted hose or line	Examine the hoses and lines, and replace as necessary.
	Front end out of alignment	Reset alignment.
Leaky Caliper	Cylinder bore surface scored or corroded	Disassemble calipers, clean bore and replace seals and boots.
	Caliper piston seal damaged or worn	Disassemble calipers and install new seals and boots.
	Caliper piston damaged	Replace piston.



Section 7 Troubleshooting

Brakes

Conditions	Possible Causes	Correction
No Braking Effect or Excessive Pedal Travel	Reservoir fluid level low	Check for causes of fluid leak, repair as required and refill the reservoir. Bleed system as needed.
	Air in the hydraulic system	Bleed the system.
	Bleeder screw loose or open	Bleed the system and tighten the bleeder screw.
	Caliper piston seal damaged	Disassemble the caliper and replace the piston seals. Replace piston if damaged.
	Excessive rotor runout or bent rotor	Check rotor with dial indicator. Install new rotor if runout exceeds maximum specified.
	Bad or excessively loose wheel bearings	Adjust or replace bearings as needed.
	Poor quality brake fluid	Drain and clean system. Replace with recommended brake fluid.
	Weak brake hose that expands under pressure	Replace defective hoses.
Brake Noise — Chatter	Excessive lateral runout of rotor	Check the runout with a dial indicator. Install new rotor if the runout exceeds the maximum specified.
	Lack of rotor parallelism	Check the parallelism with a micrometer. Resurface or install new rotor as required.
	Loose wheel bearing	Readjust the bearing to specified torque.
Brake Noise — Scraping	Rust or mud build-up on edges of rotor and on caliper housing	Clean or replace as necessary.
	Worn pad or pad installed backward	Replace pads in axle sets only with friction surface against the rotor.
	Faulty caliper alignment permitting rotor to scrape on housing	Correct the alignment.
Brake Noise — Groan	Pressure on the brake pedal too light	Slightly increase the pedal effort to eliminate noise.
Brake Noise — Rattle	Excessive clearance between the shoe and caliper	Install new pads.
	Pad retainer spring missing or not properly positioned	Install new pad retainer spring or position correctly.
Brake Noise — Squeal	Glazed pads	Resurface or replace pads in axle sets only.
	Weak pad retainer spring	Install new pad retainer spring.
	Pad wear indicator contacting rotor	Install new pads in axle sets only.
	Foreign material embedded in linings	Replace pads in axle sets only.



Section 8 Torque Specifications



Description	Specification
ABS Sensor Bolts — 5/16-18	9-12 lb-ft (12.2-16.3 N•m)
Brake Hose Hold Down Clamp Bolt — 5/16-18	9-12 lb-ft (12.2-16.3 N•m)
Banjo Bolt	30-40 lb-ft (40.8-54.4 N•m)
Pad Retainer Spring Bolt — M10x1.5x16	28-32 lb-ft (38.1-43.5 N•m)
Caliper-to-Support Bolts — M20	320-360 lb-ft (435.2-489.6 N•m)
Cross Over Tube Nuts — 7/16-24	9-12 lb-ft (12.2-16.3 N•m)
Bleed Screw — 7/16-24	9-12 lb-ft (12.2-16.3 N•m)
Lining Rail Covers — M8x1.25x14	12-18 lb-ft (16.3-24.5 N•m)
Rotor to Hub Bolt (9/16-12 bolt)	100-125 lb-ft (136.0-170.0 N•m)
Rotor to Hub Bolt (9/16-18) with Lock Nuts	70-95 lb-ft (95.2-129.2 N•m)
Rotor to Hub Bolt (9/16-18) with Plain Nuts	130-165 lb-ft (176.8-224.4 N•m)
Support to Axle (5/8-18 bolt) (9/16-18 bolt)	190-250 lb-ft (258.4-340.0 N•m) 130-165 lb-ft (176.8-224.4 N•m)

Description	Specification
Brake Pad — Thickness Above Metal (New) Minimum Thickness Above Metal (Discard)	0.73" (18.5 mm) 0.125" (3.2 mm)
Brake Fluid — High-Performance Brake Fluid	DOT 3 or DOT 4
Rotor Diameter — Thickness (New) Thickness (Discard)	15.38" (390.7 mm) 1.54" (39.1 mm) 1.42" (36.1 mm)

ArvinMeritorTM
Commercial Vehicle Systems

Meritor Heavy Vehicle Systems, LLC
2135 West Maple Road
Troy, MI 48084 USA
800-535-5560
www.arvinmeritor.com

Drivetrain PlusTM by ArvinMeritor



Information contained in this publication was in effect at the time the publication was approved for printing and is subject to change without notice or liability. ArvinMeritor Commercial Vehicle Systems reserves the right to revise the information presented or discontinue the production of parts described at any time.

Copyright 2001
ArvinMeritor, Inc.
All Rights Reserved

Maintenance Manual MM-2075
Issued 01-01
16579/24240

Printed in the USA