

Overview

The Blue Bird Vision is equipped with either SofTek™ spring suspension or AirTek™ air suspension. Both use the SteerTek™ front axle, also manufactured by Hendrickson.™

Appendixes & Other References

Appendix 1. AirTek & SofTek With SteerTek Axle. Hendrickson Publication number 17730-248 covers maintenance, adjustment, and component replacement information on:

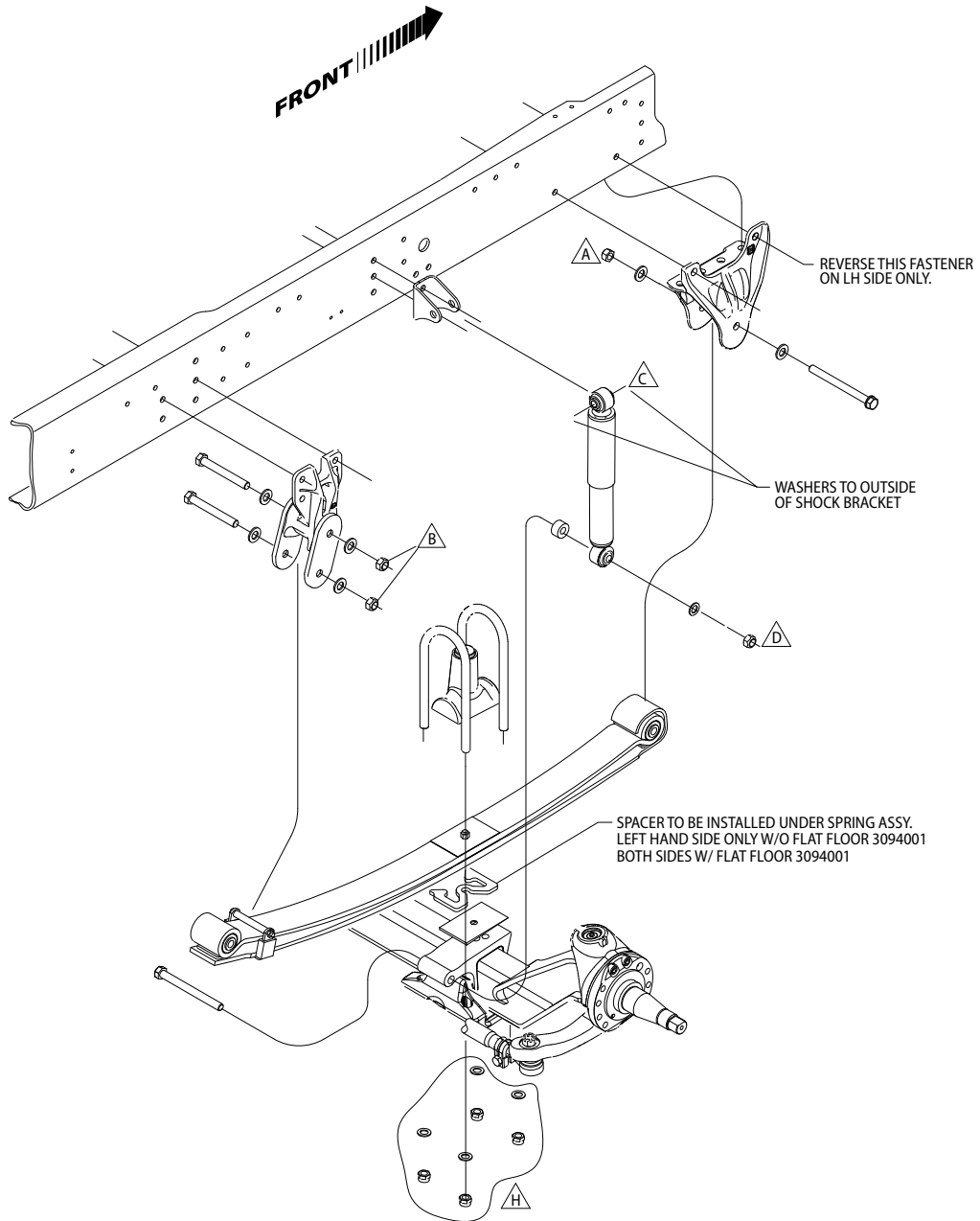
- The SteerTek axle, including wheel end components and steering linkage.
- AirTek front air suspension, including height control valves.
- SofTek leaf spring suspension.
- Front axle towing guidelines.

Also See: The Hydraulic Brakes chapter of this manual includes a procedure for removing the front disc rotor/hub assembly.

Maintenance

Maintenance of the front axle and suspension consists of periodic general inspection, checking tightness of fasteners, and lubricating grease fittings. Refer to the maintenance charts in this chapter (also included in the **Specs & Maintenance** chapter) for maintenance inspection intervals. The exploded illustrations in this chapter include torque specifications.

SofTek Front Suspension



0108979F

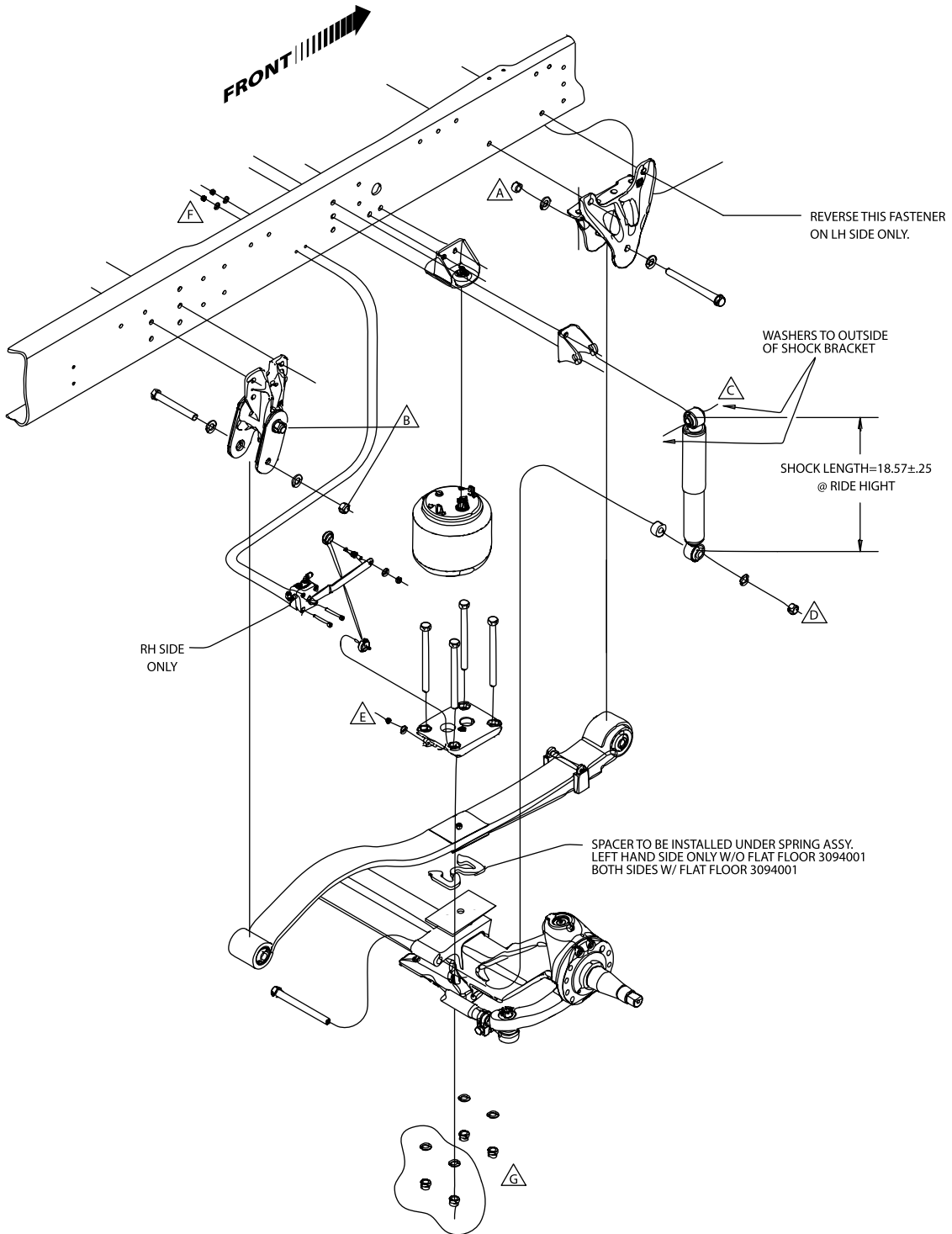


Softek Front Suspension

Torque Requirements

KEY	DESCRIPTION	THREAD	TORQUE +- 5%
A	FRONT HANGER PIVOT	M-20-2.5	GR10.9 300 FT.LBS.
B	SHACKLE BRACKET PIVOT	M-20-2.5	GR10.9 300 FT.LBS.
C	UPPER SHOCK	3/4"-10	GR8 125 FT.LBS.
D	LOWER SHOCK	3/4"-10	GR8 25 FT.LBS.
E	LINKAGE ROD ASSY LOCKNUT	5/16"-18 UNC 2B	11 FT.LBS.
F	LEVELING VALVE LOCKNUT	1/4"-20 UNC 2B	8 FT.LBS.
G	KIT,BOLT,CLAMP GROUP	3/4"-16	295 FT.LBS.
H	KIT,U-BOLT,SPRING SUSP,FRONT	3/4"-16	295 FT.LBS.
J	FRONT HANGER BOLTS	5/8"-11	15 FT.LBS.

AirTek Front Suspension



0108979F



AirTek Front Suspension

Torque Requirements

KEY	DESCRIPTION	THREAD	TORQUE +- 5%
A	FRONT HANGER PIVOT	M-20-2.5	GR10.9 300 FT.LBS.
B	SHACKLE BRACKET PIVOT	M-20-2.5	GR10.9 300 FT.LBS.
C	UPPER SHOCK	3/4"-10	GR8 125 FT.LBS.
D	LOWER SHOCK	3/4"-10	GR8 25 FT.LBS.
E	LINKAGE ROD ASSY LOCKNUT	5/16"-18 UNC 2B	11 FT.LBS.
F	LEVELING VALVE LOCKNUT	1/4"-20 UNC 2B	8 FT.LBS.
G	KIT,BOLT,CLAMP GROUP	3/4"-16	295 FT.LBS.
H	KIT,U-BOLT,SPRING SUSP,FRONT	3/4"-16	295 FT.LBS.
J	FRONT HANGER BOLTS	5/8"-11	15 FT.LBS.



AIRTEK®



SOFTEK®



H

TABLE OF CONTENTS

AIRTEK® • SOFTEK® for Blue Bird Buses
February 2007
Rev. C

Section 1	Introduction	2	Section 9	Component Replacement	
Section 2	Product Description	3		Fasteners	52
Section 3	Important Safety Notice	6		Spacers	52
Section 4	Special Tools	11		AIRTEK Height Control Valve	52
Section 5	Parts Lists			AIRTEK Air Spring	55
	AIRTEK – 10K Capacity	12		AIRTEK Front Leaf Spring Frame Hanger	59
	AIRTEK – 14.6K Capacity	14		SOFTEK Front Leaf Spring Frame Hanger	60
	SOFTEK – 8K/10K Capacity	16		AIRTEK Rear Shackle Frame Bracket	61
	SOFTEK – 13.2K/14.6K Capacity	18		SOFTEK Rear Shackle Frame Bracket	63
Section 6	Towing Procedure	21		SOFTEK Rubber Axle Stop	64
Section 7	Preventive Maintenance			Thrust Washer	64
	Visual Inspection	24		AIRTEK Leaf Spring Assembly	66
	Lubrication Intervals	25		SOFTEK Leaf Spring Assembly	69
	Kingpin Lubrication	25		Front Leaf Spring Eye Bushing	71
	Tie Rod End Lubrication	26		Shock Absorber	71
	Tie Rod End Inspection	27		AIRTEK Bottom Axle Wrap	73
	Clamp Group Re-torque Interval	29		SOFTEK Bottom Axle Wrap	74
	Tire Inspection	30		AIRTEK Top Axle Wrap (In Chassis)	75
	Shock Absorber Inspection	33		SOFTEK Top Axle Wrap (In Chassis)	78
	Shackle Thrust Washer Inspection	34		AIRTEK Front Axle Assembly	80
	Axle Wrap Liner Inspection	35		SOFTEK Front Axle Assembly	81
	Kingpin Bushing Inspection	36		STEERTEK Axle Removal	82
	Steering Knuckle Inspection	37		STEERTEK Axle (Removed From Chassis)	83
Section 8	Alignment & Adjustments			Steering Knuckle Disassembly	87
	Alignment Definitions	38		Kingpin Preparation & Measurement	88
	Inspection Prior to Alignment	41		Kingpin Bushing Removal	90
	Front Wheel Alignment	42		Steering Knuckle Bore Measurement	91
	AIRTEK Ride Height Adjustment	44		Kingpin Bushing Installation	91
	AIRTEK Height Control Valve Test	46		Kingpin Bushing Reaming	92
	Steering Stop	47		Kingpin Seal Installation	93
	Toe Setting	48		Steering Knuckle Assembly	94
	Spring Eye Re-torque	50		Tie Rod End and Cross Tube	96
			Section 10	AIRTEK Plumbing Diagrams	
				10K Capacity	98
				14.6K Capacity	99
			Appendix	Trouble Shooting Guide	A-100
				Tightening Torque Specifications	A-102
				Front Alignment Specifications	A-110
				Reference Material	A-112
				Technical Procedure Publication Quiz	A-113



SECTION 1
Introduction

70

This publication is intended to acquaint and assist maintenance personnel in the preventive maintenance, service, repair and rebuild of the following Hendrickson equipment as installed on applicable Blue Bird Buses:

- **AIRTEK®** — An integrated front air suspension with the STEERTEK axle.
- **SOFTEK®** — An integrated steel spring mechanical suspension with the STEERTEK axle.
- **STEERTEK** — A lightweight, formed and robotically welded steer axle assembly.

NOTE

Use only  Hendrickson Genuine parts for servicing this suspension system.

It is important to read and understand the entire Technical Procedure publication prior to performing any maintenance, service, repair, or rebuild of the product. The information in this publication contains parts lists, safety information, product specifications, features, proper maintenance, service, repair and rebuild instructions for the AIRTEK Suspension and the STEERTEK axle.

A Technical Procedure Quiz has been included at the back of this publication. Hendrickson will provide personalized AIRTEK/SOFTEK Technical Procedure Quiz Achievement Certificate to candidates scoring 80% or higher on the test. Simply complete the test and fill in the enclosed answer sheet or write your answers on a separate sheet with the return address, name, phone number, and company name as it will appear on the award to:

Hendrickson
ATTN: Truck Marketing Test Quiz Assessment
800 S. Frontage Road
Woodridge, Illinois 60517

Hendrickson reserves the right to make changes and improvements to its products and publications at any time. Contact Hendrickson Tech Services at 630-910-2800 or e-mail techservices@hendrickson-intl.com for information on the latest version of this manual.

The latest revision of this publication is also available online at www.hendrickson-intl.com.





AIRTEK®• SOFTEK® for Blue Bird Buses

SECTION 2 Product Description

FIGURE 2-1 AIRTEK®
Air Suspension System with STEERTEK Axle
for Blue Bird Vision Buses
Capacity: 10,000 pounds

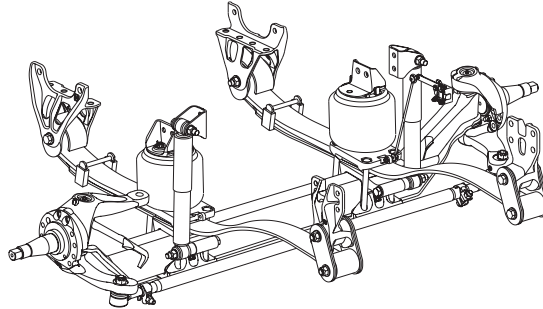


FIGURE 2-2 AIRTEK®
Air Suspension System with STEERTEK Axle
for Blue Bird All American Buses
Capacity: 14,600 pounds

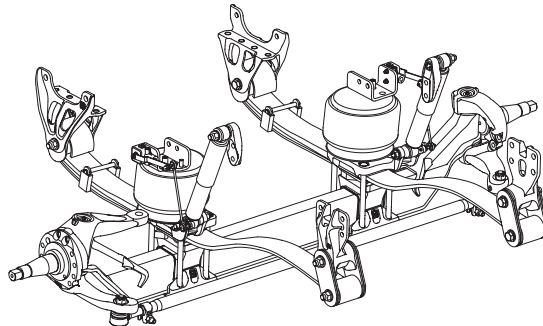


FIGURE 2-3 SOFTEK®
Mechanical Suspension System with STEERTEK Axle
for Blue Bird Vision Buses
Capacity: 8,000/10,000 pounds

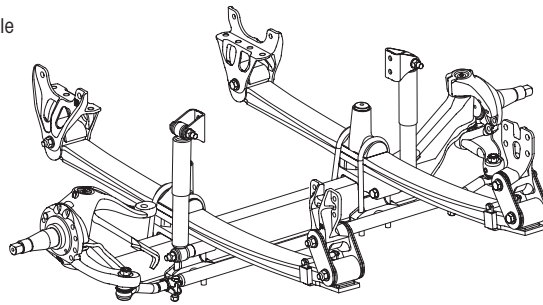
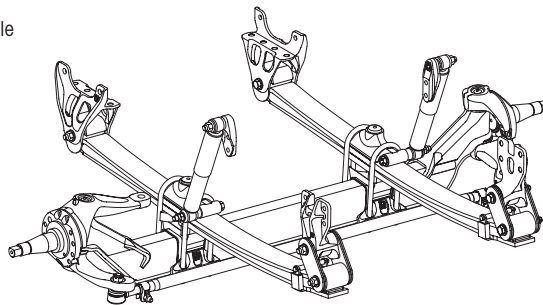


FIGURE 2-4 SOFTEK®
Mechanical Suspension System with STEERTEK Axle
for Blue Bird All American Buses
Capacity: 13,200/14,600 pounds



AIRTEK® • SOFTEK® for Blue Bird Buses



SOFTEK — is an integrated front mechanical suspension and robotically welded steer axle that work together to form an integrated torsion system. Utilizing a system approach, Hendrickson has engineered and optimized the following components to form a system delivering ride, stability and handling characteristics with reduced weight and maintenance.

Leaf Spring Assembly — With its innovative design, the leaf spring provides superior stability, performance and a soft ride. Durable rubber front and patented rear bushings are greaseless and only require periodic inspections.

Shock Absorbers — SOFTEK utilizes premium shocks that have been tested and tuned specifically for the SOFTEK system.

Frame Brackets — Optimized design delivers weight reduction and proven durability. The front and rear frame brackets are common between the SOFTEK and AIRTEK suspensions.

AIRTEK — Winner of the 2001 Automotive News and Cap Gemini Ernst & Young PACE Award for Product Innovation. AIRTEK is an integrated front air suspension and robotically welded steer axle that work together to form an integrated torsion system. Utilizing a system approach, Hendrickson has engineered and optimized the following components to form a system delivering ride, stability and handling characteristics with reduced weight and maintenance.

AIRTEK Air Springs — Exclusive to Hendrickson, the lightweight air springs deliver a soft ride. The air springs are engineered to support 78% of the vertical load while providing a low spring rate. The quick “snap” design for the 10,000 pound capacity, the bolt on design for the 14,600 pound capacity, and the “push-to-connect” air supply design also provide fast and easy removal and installation.

Leaf Spring Assembly — With its innovative design, the leaf spring provides superior stability, performance and a soft ride. The patented leaf spring shares loads with the air spring. Durable rubber front and patented rear bushings are greaseless and only require periodic inspections.

Shock Absorbers — AIRTEK/SOFTEK utilizes premium shocks that have been tested and tuned specifically for the suspension system.

Axle Beam — The box-shaped design provides a stiffer axle and resists torsional, longitudinal and vertical loads more effectively than traditional axle beams. Together with the front limbs of the leaf springs, the robotically welded axle beam forms a torsion system, enhancing roll stability characteristics and improving handling.

Axle Clamp Group — The patented clamp group provides four-sided clamping pressure. The Clamp Group consists of the following:

- Top Axle Wrap
- Top Axle Wrap Liner
- Top Spring Pad
- Bottom Axle Wrap
- Bottom Axle Wrap Liner
- ¾" Bolts, Washers and Locknuts

Adjustable Tie Rod — To help maximize tire life, the tie rod easily adjusts toe-in/out.

Knuckles — The steering and tie rod arms are integrated for increased strength and reduced weight. The unique steering knuckle packaging delivers a maximum of 50° wheel cut. The two piece knuckle design makes servicing the kingpin bushings easier.





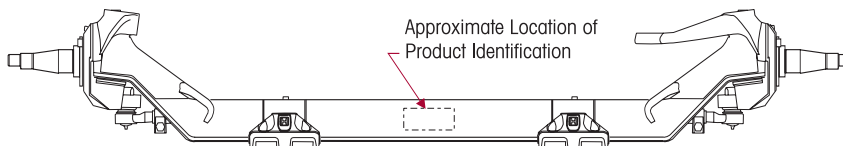
AIRTEK®• SOFTEK® for Blue Bird Buses

73

TECHNICAL NOTES

1. AIRTEK and SOFTEK are approved for 100% on-highway use; other applications must be pre-approved by Hendrickson Sales Engineering. System capacity rating for the suspension represents maximum loads on tires at ground level.
2. The STEERTEK axle for the Vision is available with 69" kingpin intersection (KPI). The STEERTEK axle for the All American is available with 71" kingpin intersection (KPI).
3. AIRTEK suspension weight includes frame and shackle bracket assemblies, main springs, bushings, air springs and air spring bracket, height control system, shocks, upper shock brackets and axle clamp group.
4. SOFTEK suspension weight includes frame and shackle bracket assemblies, steel leaf springs, bushings, shocks, upper shock brackets and axle clamp group.
5. STEERTEK axle weight includes, the axle beam, knuckle/steering arm assemblies and tie rod assemblies.
6. AIRTEK and SOFTEK are integral to and available exclusively with the STEERTEK axle. This system is anti-lock braking system (ABS) ready. STEERTEK is compatible with most industry standard wheel ends and brakes. Contact OEM for more information.
7. The STEERTEK axle product identification is etched on the center front of the axle beam providing the following information:
 - Axle part number: Identifies the features of the axle beam.
 - Axle assembly number: Identifies the complete assembly, which includes the steering knuckles and bracket assemblies.

FIGURE 2-5 Front view of STEERTEK axle showing approximate location of Product Identification.





SECTION 3 Important Safety Notice

Proper maintenance, service and repair is important to the reliable operation of the suspension. The procedures recommended by Hendrickson and described in this technical publication are methods of performing such maintenance, service and repair.

The warnings and cautions should be read carefully to help prevent personal injury and to assure that proper methods are used. Improper maintenance, service or repair may damage the vehicle, cause personal injury, render the vehicle unsafe in operation, or void the manufacturer's warranty.

Failure to follow the safety precautions in this manual can result in personal injury and/or property damage. Carefully read and understand all safety related information within this publication, on all decals and in all such materials provided by the vehicle manufacturer before conducting any maintenance, service or repair.

EXPLANATION OF SIGNAL WORDS

Hazard "Signal Words" (Danger-Warning-Caution) appear in various locations throughout this publication. Information accented by one of these signal words must be observed to help minimize the risk of personal injury to service personnel, or possibility of improper service methods which may damage the vehicle or render it unsafe.



This is the safety alert symbol. It is used to alert you to potential personal injury hazards. Obey all safety messages that follow this symbol to avoid possible injury or death.

Additional 'Notes' or 'Service Hints' are utilized to emphasize areas of procedural importance and provide suggestions for ease of repair. The following definitions indicate the use of these signal words as they appear throughout the publication.

 **DANGER**

INDICATES AN IMMINENTLY HAZARDOUS SITUATION WHICH, IF NOT AVOIDED, WILL RESULT IN SERIOUS INJURY OR DEATH.

 **WARNING**

INDICATES A POTENTIAL HAZARDOUS SITUATION WHICH, IF NOT AVOIDED, CAN RESULT IN SERIOUS INJURY OR DEATH.

 **CAUTION**

INDICATES A POTENTIAL HAZARDOUS SITUATION WHICH, IF NOT AVOIDED, MAY RESULT IN MINOR OR MODERATE INJURY, OR PROPERTY DAMAGE.

NOTE

An operating procedure, practice condition, etc. which is essential to emphasize.

SERVICE HINT

A helpful suggestion, which will make the servicing being performed a little easier and/or faster.

Also note that particular service operations may require the use of special tools designed for specific purposes. These special tools can be found in the Special Tools Section of this publication.



AIRTEK®• SOFTEK® for Blue Bird Buses

SAFETY PRECAUTIONS



WARNING

FASTENERS

LOOSE OR OVER TORQUED FASTENERS CAN CAUSE COMPONENT DAMAGE, LOSS OF VEHICLE CONTROL, PROPERTY DAMAGE, OR SEVERE PERSONAL INJURY. MAINTAIN CORRECT TORQUE VALUE AT ALL TIMES. CHECK TORQUE VALUES ON A REGULAR BASIS AS SPECIFIED.



DANGER

AIR SPRINGS

AIR SPRING ASSEMBLIES MUST BE DEFLATED PRIOR TO LOOSENING ANY CLAMP GROUP HARDWARE. UNRESTRICTED AIR SPRING ASSEMBLIES CAN VIOLENTLY SHIFT. DO NOT INFLATE AIR SPRING ASSEMBLIES WHEN THEY ARE UNRESTRICTED. AIR SPRING ASSEMBLIES MUST BE RESTRICTED BY SUSPENSION OR OTHER ADEQUATE STRUCTURE. DO NOT INFLATE BEYOND PRESSURES RECOMMENDED BY AIR SPRING MANUFACTURER, CONTACT HENDRICKSON TECHNICAL SERVICES FOR DETAILS. IMPROPER USE OR OVER INFLATION MAY CAUSE AIR SPRING ASSEMBLIES TO BURST, CAUSING PROPERTY DAMAGE AND/OR SEVERE PERSONAL INJURY.



WARNING

WHEN SERVICING THE VEHICLE OR ATTACHING AN AIR SPRING AND THE VEHICLE IS ON THE GROUND, PRIOR TO AIRING THE SUSPENSION SYSTEM MAKE CERTAIN THE AIR SPRING LOCATOR IS INDEXED INTO THE UPPER AIR SPRING BRACKET PROPERLY, AND THE AIR SPRING IS FULLY SEATED ON THE SPRING TOP PAD. FAILURE TO FOLLOW THESE INSTRUCTIONS CAN RESULT IN PREMATURE AIR SPRING FAILURE, CAUSE PERSONAL INJURY, OR PROPERTY DAMAGE.



WARNING

PRIOR TO AND DURING DEFLATION AND INFLATION OF THE FRONT AIR SUSPENSION SYSTEM, ENSURE THAT ALL PERSONNEL AND EQUIPMENT ARE CLEAR FROM UNDER THE VEHICLE AND AROUND THE SERVICE AREA, FAILURE TO DO SO CAN CAUSE SERIOUS PERSONAL INJURY, DEATH, OR PROPERTY DAMAGE.



WARNING

LOAD CAPACITY

ADHERE TO THE PUBLISHED CAPACITY RATINGS FOR THE SUSPENSIONS. ADD-ON AXLE ATTACHMENTS (I.E. SLIDING FIFTH WHEELS) AND OTHER LOAD TRANSFERRING DEVICES CAN INCREASE THE SUSPENSION LOAD ABOVE THE RATED AND APPROVED CAPACITIES WHICH CAN RESULT IN FAILURE AND LOSS OF VEHICLE CONTROL, POSSIBLY CAUSING PERSONAL INJURY OR PROPERTY DAMAGE.



WARNING

MODIFYING COMPONENTS

DO NOT MODIFY OR REWORK PARTS. DO NOT SUBSTITUTE PARTS OF THE SUSPENSION OR AXLE COMPONENTS, USE OF A MODIFIED OR REPLACEMENT PARTS NOT AUTHORIZED BY HENDRICKSON MAY NOT MEET HENDRICKSON'S SPECIFICATIONS, AND CAN RESULT IN FAILURE OF THE PART, LOSS OF VEHICLE CONTROL, AND POSSIBLE PERSONAL INJURY OR PROPERTY DAMAGE. USE ONLY HENDRICKSON AUTHORIZED REPLACEMENT PARTS, DO NOT MODIFY PARTS WITHOUT AUTHORIZATION FROM HENDRICKSON.



WARNING

SHOCK ABSORBERS

THE SHOCK ABSORBERS ARE THE REBOUND TRAVEL STOPS FOR THE SPRINGS. ANYTIME THE FRONT AXLE ON AN AIRTEK SUSPENSION IS SUSPENDED IT IS MANDATORY THAT THE SHOCK ABSORBERS REMAIN CONNECTED. FAILURE TO DO SO CAN CAUSE THE AIR SPRINGS TO EXCEED THEIR MAXIMUM LENGTH, POSSIBLY CAUSING THE AIR SPRINGS TO SEPARATE FROM THE PISTON, OR CAUSE A REVERSE ARCH IN THE STEEL LEAF SPRINGS, POSSIBLY RESULTING IN PREMATURE STEEL LEAF SPRING FAILURE.

AIRTEK® • SOFTEK® for Blue Bird Buses



WARNING

TORCH/WELDING

DO NOT USE A CUTTING TORCH TO REMOVE ANY ATTACHING FASTENERS. THE USE OF HEAT ON SUSPENSION COMPONENTS WILL ADVERSELY AFFECT THE STRENGTH OF THESE PARTS. A COMPONENT DAMAGED IN THIS MANNER CAN RESULT IN THE LOSS OF VEHICLE CONTROL AND POSSIBLE PERSONAL INJURY OR PROPERTY DAMAGE.

EXERCISE EXTREME CARE WHEN HANDLING OR PERFORMING MAINTENANCE IN THE AREA OF THE SPRING ASSEMBLY AND AXLE. DO NOT CONNECT ARC WELDING GROUND LINE TO THE SPRING ASSEMBLY OR AXLE. DO NOT STRIKE AN ARC WITH THE ELECTRODE ON THE SPRING ASSEMBLY OR AXLE. DO NOT USE HEAT NEAR THE SPRING ASSEMBLY OR AXLE. DO NOT NICK OR GOUGE THE SPRING ASSEMBLY OR AXLE. SUCH IMPROPER ACTIONS CAN CAUSE DAMAGE TO THE SPRING ASSEMBLY OR THE AXLE CAN FAIL, AND CAN CAUSE LOSS OF VEHICLE CONTROL AND POSSIBLE PERSONAL INJURY OR PROPERTY DAMAGE.

WARNING

OFF ROADWAY TOWING

WHEN A VEHICLE IS DISABLED AND EQUIPPED WITH A STEERTEK AXLE, CARE MUST BE TAKEN TO ENSURE THERE IS NO DAMAGE TO THE SUSPENSION WHEN TOWING THE VEHICLE. THE USE OF A TOW STRAP IS NECESSARY TO TOW A DISABLED VEHICLE INTO A REPAIR FACILITY PARKING LOT INTO THE SHOP BAY. THE TOW STRAPS SHOULD BE CONNECTED TO THE TOW HOOKS PROVIDED BY THE MANUFACTURER AT THE FRONT OF THE BUMPER. IF THE USE OF TOW HOOKS IS NOT AN OPTION THEN A TOW STRAP MAY BE WRAPPED AROUND THE FRONT AXLE (SEE FIGURE 3-1) IN A MANNER THAT IS ACCEPTABLE FOR TOWING THE VEHICLE INTO THE SHOP. DO NOT USE A TOW CHAIN AROUND THE FRONT AXLE OR WITH A SINGLE POINT LOCATION TO TOW THE VEHICLE, DOING SO WILL DAMAGE THE AXLE, SEE FIGURE 3-2. FOR DETAILED TOWING INSTRUCTIONS FOR ON-HIGHWAY TOWING SEE SECTION 6.

FIGURE 3-1 ACCEPTABLE



FIGURE 3-2 NOT ACCEPTABLE



CAUTION

PROCEDURES AND TOOLS

A MECHANIC USING A SERVICE PROCEDURE OR TOOL WHICH HAS NOT BEEN RECOMMENDED BY HENDRICKSON MUST FIRST SATISFY HIMSELF THAT NEITHER HIS SAFETY NOR THE VEHICLE'S SAFETY WILL BE JEOPARDIZED BY THE METHOD OR TOOL SELECTED. INDIVIDUALS DEVIATING IN ANY MANNER FROM THE INSTRUCTIONS PROVIDED ASSUME ALL RISKS OF CONSEQUENTIAL PERSONAL INJURY OR DAMAGE TO EQUIPMENT INVOLVED.

WARNING

PERSONNEL PROTECTIVE EQUIPMENT

ALWAYS WEAR PROPER EYE PROTECTION AND OTHER REQUIRED PERSONAL PROTECTIVE EQUIPMENT TO HELP PREVENT PERSONAL INJURY WHEN YOU PERFORM VEHICLE MAINTENANCE, REPAIR OR SERVICE.



AIRTEK®• SOFTEK® for Blue Bird Buses

WARNING

SUPPORT THE VEHICLE PRIOR TO SERVICING

PLACE THE VEHICLE ON A LEVEL FLOOR AND CHOCK THE WHEELS TO HELP PREVENT THE VEHICLE FROM MOVING. NEVER WORK UNDER A RAISED VEHICLE SUPPORTED BY ONLY A FLOOR JACK. ALWAYS SUPPORT A RAISED VEHICLE WITH SAFETY STANDS. BLOCK THE WHEELS AND MAKE SURE THE UNIT WILL NOT ROLL BEFORE RELEASING BRAKES. A JACK CAN SLIP OR FALL OVER. SERIOUS PERSONAL INJURY CAN RESULT.

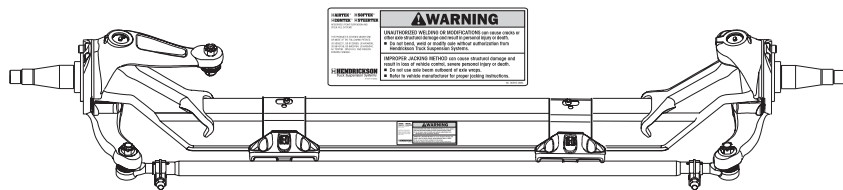
WARNING

AXLE

AXLE CAMBER IS NOT ADJUSTABLE. DO NOT CHANGE THE AXLE CAMBER ANGLE OR BEND THE AXLE BEAM. BENDING THE AXLE BEAM (SEE FIGURE 3-3) TO CHANGE THE CAMBER ANGLE WILL DAMAGE THE AXLE AND REDUCE AXLE STRENGTH, **AND WILL VOID HENDRICKSON'S WARRANTY.** A BENT AXLE BEAM CAN CAUSE LOSS OF VEHICLE CONTROL, POSSIBLY CAUSING PERSONAL INJURY OR PROPERTY DAMAGE.

FIGURE 3-3

REPLACE ANY SAFETY DECALS THAT ARE FADED, TORN, MISSING, ILLEGIBLE, OR OTHERWISE DAMAGED. CONTACT HENDRICKSON TO ORDER REPLACEMENT LABELS.



STEERTEK IS A UNIQUE AXLE, IN THAT THE KINGPIN IS CRYOGENICALLY INSTALLED IN THE AXLE. THE KINGPIN IS A NON-REPLACEABLE COMPONENT OF THE AXLE ASSEMBLY. DO NOT TRY TO REMOVE THE KINGPIN. IF THE KINGPIN SHOWS SIGNS OF MOVEMENT, CONTACT THE HENDRICKSON TECH SERVICES DEPARTMENT.

THE REPAIR OR RECONDITIONING OF SUSPENSION OR AXLE COMPONENTS IS NOT ALLOWED AS SHOWN ON LABEL IN FIGURE 3-3. HENDRICKSON ADVISES REPLACING ALL COMPONENTS FOUND TO BE DAMAGED OR OUT OF SPECIFICATIONS. ALL MAJOR HENDRICKSON COMPONENTS ARE HEAT TREATED AND TEMPERED. AIRTEK/SOFTEK COMPONENTS CANNOT BE BENT, WELDED, HEATED, OR REPAIRED WITHOUT REDUCING THE STRENGTH OR LIFE OF THE COMPONENT. FAILURE TO FOLLOW THESE GUIDELINES CAN CAUSE LOSS OF VEHICLE CONTROL, POSSIBLE PERSONAL INJURY, DEATH, OR PROPERTY DAMAGE AND WILL VOID APPLICABLE WARRANTIES.

IF A VEHICLE EQUIPPED WITH A STEERTEK AXLE IS INVOLVED IN A CRASH, A THOROUGH INSPECTION OF THE AXLE SHOULD BE PERFORMED NOTING THE CONDITION OF THE AXLE BEAM, KINGPINS, AND KNUCKLE ASSEMBLIES. IF ANY COMPONENT APPEARS DAMAGED THE AXLE SHOULD BE REPLACED. IN THE EVENT THE CRASH RESULTED IN EXCESSIVE SIDE LOAD SUCH AS A BENT WHEEL, HUB, OR SPINDLE, IT IS STRONGLY RECOMMENDED TO REPLACE THE COMPLETE AXLE ASSEMBLY, CONTACT HENDRICKSON TECHNICAL SERVICES WITH ANY QUESTIONS. FAILURE TO REPLACE ANY DAMAGED COMPONENTS CAN CAUSE LOSS OF VEHICLE CONTROL, POSSIBLE PERSONAL INJURY, DEATH, OR PROPERTY DAMAGE AND WILL VOID APPLICABLE WARRANTIES.

AIRTEK® • SOFTEK® for Blue Bird Buses**WARNING****PARTS CLEANING**

SOLVENT CLEANERS CAN BE FLAMMABLE, POISONOUS AND CAUSE BURNS. TO HELP AVOID SERIOUS PERSONAL INJURY, CAREFULLY FOLLOW THE MANUFACTURER'S PRODUCT INSTRUCTIONS AND GUIDELINES AND THE FOLLOWING PROCEDURE:

1. WEAR PROPER EYE PROTECTION
2. WEAR CLOTHING THAT PROTECTS YOUR SKIN
3. WORK IN A WELL VENTILATED AREA
4. DO NOT USE GASOLINE, OR SOLVENTS THAT CONTAIN GASOLINE. GASOLINE CAN EXPLODE
5. HOT SOLUTION TANKS OR ALKALINE SOLUTIONS MUST BE USED CORRECTLY. FOLLOW THE MANUFACTURER'S RECOMMENDED INSTRUCTIONS AND GUIDELINES CAREFULLY TO HELP PREVENT PERSONAL ACCIDENT OR INJURY

DO NOT USE HOT SOLUTION TANKS OR WATER AND ALKALINE SOLUTIONS TO CLEAN GROUND OR POLISHED PARTS. DOING SO WILL CAUSE DAMAGE TO THE PARTS AND VOID WARRANTY.



SECTION 4
Special Tools

KINGPIN BUSHING TOOLS

FIGURE 4-1

Driver for Kingpin Bushing Installation

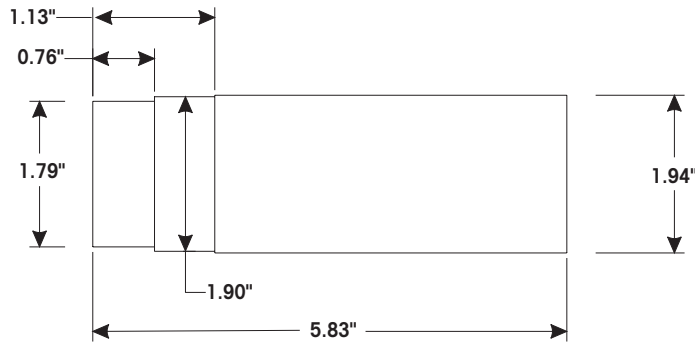


FIGURE 4-2

Steering Arm Receiver

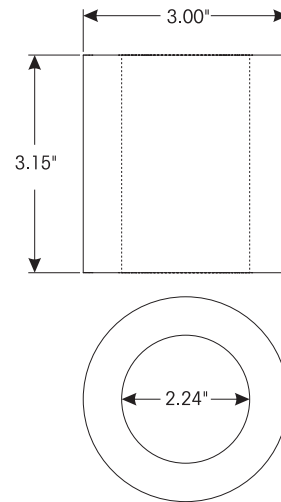


FIGURE 4-3

Driver for Kingpin Bushing Removal

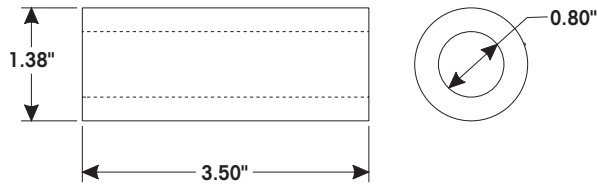


FIGURE 4-4

Adjustable Straight Flute Reamer

The dimension of cutting diameter must facilitate a range of 1.802" – 1.812"

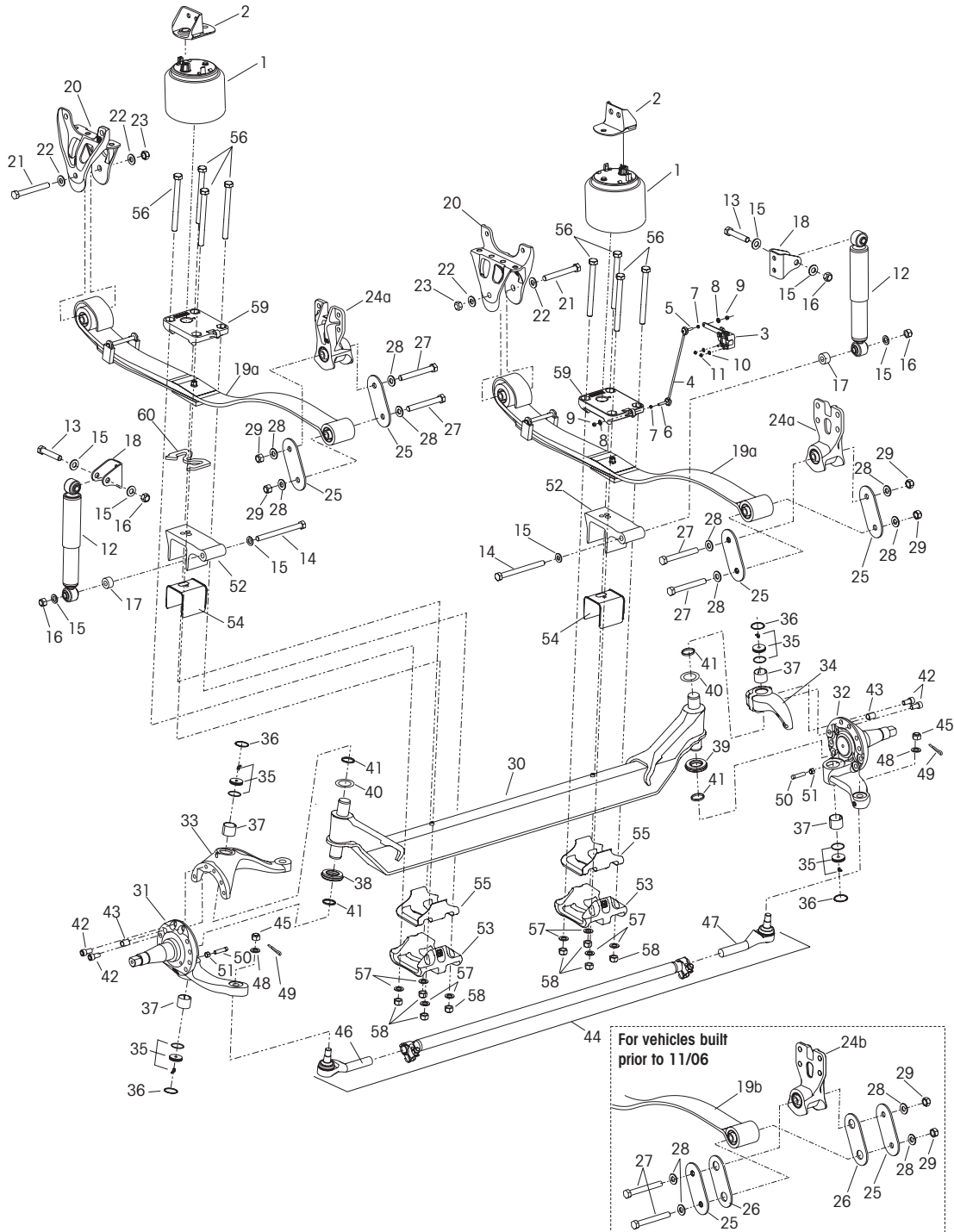


SECTION 5
Parts List

Blue Bird Vision Buses - 10K Capacity



80





AIRTEK® for Blue Bird Vision Buses - 10K Capacity

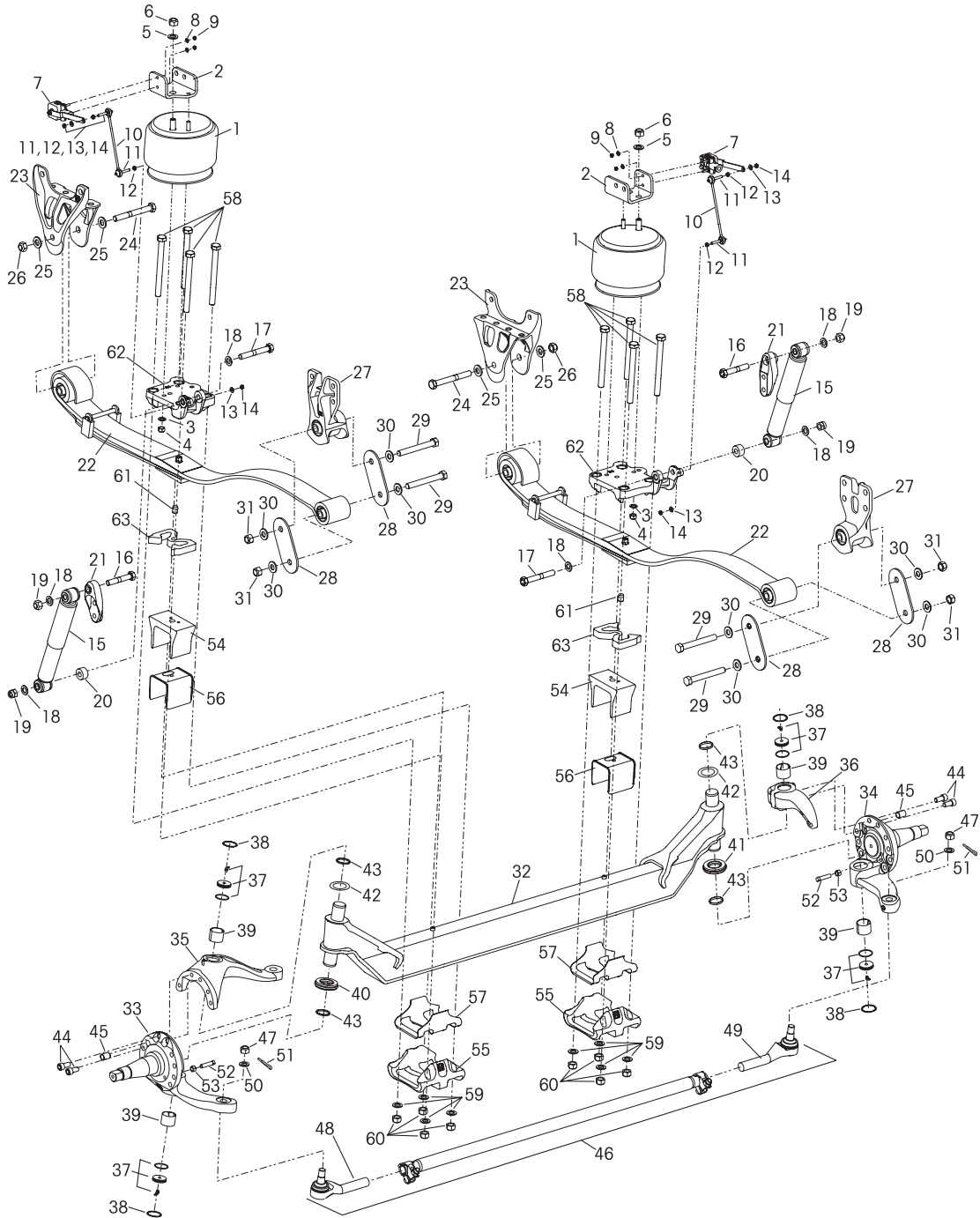
81

KEY NO.	PART NO.	DESCRIPTION	NO.REQ.
1	64075-002L	Air Spring	2
2	60850-001	Air Spring Bracket	2
	59427-008	HCV, Link Mount & Linkage Assembly (Includes Key Nos. 3-11)	1
3	59935-004	Height Control Valve	1
4	59428-001	HCV Linkage	1
	64742-001	Link Mount Service Kit (Includes Key Nos. 5-6)	
5		* $\frac{1}{8}$ "-18 UNC Stud - 2.07"	1
6		* $\frac{1}{8}$ "-18 UNC Stud - 2.44"	1
7		* $\frac{1}{8}$ "-18 UNC Hex Nut	2
8		* $\frac{1}{8}$ " Hardened Washer	2
9		* $\frac{1}{8}$ "-18 UNC Locknut	2
10		* $\frac{1}{4}$ " Hardened Washer	2
11		* $\frac{1}{4}$ "-20 UNC Locknut	2
12	58913-009L	Shock Absorber (Replaces 58913-008)	2
13		** $\frac{3}{4}$ "-10 UNC Upper Shock Bolt	2
14		** $\frac{3}{4}$ "-10 UNC Lower Shock Bolt	2
15		** $\frac{3}{4}$ " Hardened Washer	8
16		** $\frac{3}{4}$ "-10 UNC Hex Locknut	4
17	59946-001	Shock Spacer	2
18	59423-002	Shock Bracket	2
	60961-163	Leaf Spring Assembly Service Kit <i>For vehicles built prior to 11/06</i> (Includes Key Nos. 19a, 24a, 25)	
		Leaf Spring Assembly	2
19a	66805-001	<i>For vehicles built after 11/06</i>	
19b	60512-000	<i>For vehicles built prior to 11/06</i>	
20	64488-000	Front hanger	2
21		**M20 Hex Bolt - 170mm	2
22		**M20 Hardened Washer	4
23		**M20 Locknut	2
		Rear Shackles Bracket	2
24a	66510-001	<i>For vehicles built after 11/06</i>	
24b	64316-000	<i>For vehicles built prior to 11/06</i>	
25	64314-000	Rear Shackles Plate	4
26	64159-000	Thrust Washer <i>Only for vehicles built prior to 11/06</i>	4
27		**M20 Hex Bolt - 150mm	4
28		**M20 Hardened Washer	8
29		**M20 Locknut	4
	60952-XXX	Axle Assembly (Includes Key Nos. 30-53) Contact Hendrickson Tech Serv. for Part No.	1
30	64905-004	Axle & Kingpin Assembly 6.5", 8.5" Ride Height	1
31		LH Lower Steering Knuckle Assembly	1
	58900-035	150 Ackermann Air Brake	
	58900-033	200 Ackermann Air Brake	
	58900-031	250 Ackermann Air Brake	
	58900-055	150 Ackermann Hydraulic Brake	
	58900-053	200 Ackermann Hydraulic Brake	
	58900-051	250 Ackermann Hydraulic Brake	
32		RH Lower Steering Knuckle Assembly	1
	58900-036	150 Ackermann Air Brake	
	58900-034	200 Ackermann Air Brake	
	58900-032	250 Ackermann Air Brake	
	58900-056	150 Ackermann Hydraulic Brake	
	58900-054	200 Ackermann Hydraulic Brake	
	58900-052	250 Ackermann Hydraulic Brake	
33	60903-016	LH Upper Steering Knuckle Assembly	1
34	60904-002	RH Upper Steering Knuckle Assembly	1
	60961-040	Kingpin Bushing and Bearing Service Kit, Axle Set (Includes Kit Nos. 60961-009 & -039)	
	60961-009	LH Kingpin Bushing w/Composite Thrust Bearing Service Kit (Includes Key Nos.35-38, 40-42, Loctite)	

KEY NO.	PART NO.	DESCRIPTION	NO.REQ.
	60961-039	RH Kingpin Bushing w/Roller Thrust Bearing Service Kit (Includes Key Nos.35-37, 39-42, Loctite)	
35	59156-000	Grease Cap Assembly	4
36	58937-000	Retaining Ring	4
37	58909-000	Kingpin Bushing	4
	60961-043	Thrust Bearing Service Kit, Axle Set (Includes Kit Nos. 60961-041 & 60961-042)	
	60961-041	LH Composite Thrust Bearing Service Kit (Includes Key Nos. 38, 40-42, Loctite)	
	60961-042	RH Roller Thrust Bearing Service Kit (Includes Key Nos. 39-42, Loctite)	
38	59828-000	LH Composite Thrust Bearing	1
39	64256-000	RH Roller Thrust Bearing	1
40	60259-002	Kingpin Shim - 0.047"	2
Not Shown	60259-001	Kingpin Shim - 0.005" (As needed for service)	
41	58910-000	Kingpin Seal	4
42	60236-001	$\frac{5}{8}$ "-11 UNC Socket Head Cap Screw	4
Not Shown	60937-000	Loctite (Red) Compound Tube	1
43	64246-000	ABS Sensor Sleeve	2
44		***Tie Rod Assembly, 10K, 5.36 Drop (Includes Key Nos. 45-49)	1
	66699-003	200 Ackermann (Replaces 59948-005)	
	66699-001	250 Ackermann (Replaces 59948-006)	
45		* $\frac{7}{8}$ " Castile Nut	2
	60961-139	*** Tie Rod End Service Kit, Axle Set (Replaces 60961-012) (Includes Kit Nos. 60961-137 & -138)	
	60961-137	*** LH Tie Rod End Service Kit (Replaces 60961-029) (Includes Key Nos. 46, 48-49)	
	60961-138	*** RH Tie Rod End Service Kit (Replaces 60961-030) (Includes Key Nos. 47-49)	
46	66645-001	***LH Tie Rod End (Replaces 64004-001)	1
47	66645-002	***RH Tie Rod End (Replaces 64004-002)	1
48	22962-007	$\frac{7}{8}$ " Flat Washer	2
49	17800-004	Tie Rod Nut Cotter Pin	2
	60961-069	Stop Bolt Service Kit, One Side (Includes Key Nos. 50-51)	
50	60238-001	$\frac{1}{2}$ "-13 UNC Square Head Bolt	2
51	60240-000	$\frac{1}{2}$ "-13 UNC Hex Jam Nut	2
52	59952-003	Top Axle Wrap	2
53	64722-003	Bottom Axle Wrap	2
	60961-015	Top/Bottom Axle Wrap Liner Service Kit, One Side (Includes Key Nos. 54-55)	
54	60508-000	Top Axle Wrap Liner	2
55	59845-000	Bottom Axle Wrap Liner	2
		Clamp Group Service Kit, One Side (Includes Key Nos. 56-58)	
	60961-051	6.5" Ride Height	
	60961-052	8.5" Ride Height	
56		$\frac{3}{4}$ "-16 UNC Hex bolt	8
	21867-044	6.5" Ride Height - 10.0"	
	21867-045	8.5" Ride Height - 12.0"	
57	22962-001	$\frac{3}{4}$ " Flat Washer	8
58	17700-035	$\frac{3}{4}$ "-16 UNC 2B Nylon Locknut	8
Not Shown	18831-021	Dowel Pin, 8.5" Ride Height - 2.0"	2
59		Top Pad	
	64516-001	LH	1
	64516-002	RH	1
60		Front Axle Spacer	
	64536-010	LH 6.5" Ride Height	1
	64536-060	LH 8.5" Ride Height	1
Not Shown	64536-050	RH 8.5" Ride Height	1



Blue Bird All American Buses - 14.6K Capacity





AIRTEK® for Blue Bird All American Buses - 14.6K

83

KEY NO.	PART NO.	DESCRIPTION	NO.REQ.
1	66865-002L	Air Spring	2
2	66807-001	Air Spring Bracket	2
3	22962-014	1/2" Hardened Washer	2
4	17730-015	1/2"-13 UNC Nylon Locknut	2
5		**3/4" Hardened Washer	2
6		**3/4"-10 UNC Nylon Locknut	2
	59013-000	Height Control Valve Assembly (Includes Key Nos. 7-9)	2
7	60501-000	Height Control Valve	2
8	22962-028	1/4" Hardened Washer	4
9	49983-000	1/4"-20 UNC Locknut	4
	66825-001	HCV Linkage Assembly (Includes Key Nos. 10-14)	2
10	59428-005	HCV Linkage	2
11		*9/16"-18 UNC Stud - 2.44"	4
12		*9/16"-18 UNC Hex Nut	4
13		*9/16" Hardened Washer	4
14		*9/16"-18 UNC Locknut	4
15	58913-011L	Shock Absorber	2
16		**3/4"-10 UNC Upper Shock Bolt	2
17		**3/4"-10 UNC Lower Shock Bolt	2
18		**3/4" Hardened Washer	6
19		**3/4"-10 UNC Hex Locknut	4
20	59946-006	Shock Spacer	2
21	65000-002	Shock Bracket	2
22	66805-001	Leaf Spring Assembly	2
23	64488-002	Front Hanger	2
24		**M20 Hex Bolt - 170mm	2
25		**M20 Hardened Washer	4
26		**M20 Locknut	2
27	66510-001	Rear Shackle Bracket	2
28	64314-000	Rear Shackle Plate	4
29		**M20 Hex Bolt - 150mm	4
30		**M20 Hardened Washer	8
31		**M20 Locknut	4
	60952-XXX	Axle Assembly (Includes Key Nos. 32-55) Contact Hendrickson Tech Serv. for Part No.	1
32	64905-007	Axle & Kingpin Assembly 6.8", 7.8", 8.8" and 9.8" Ride Height	1
33		LH Lower Steering Knuckle Assembly	1
	58900-035	150 Ackermann Air Brake	
	58900-033	200 Ackermann Air Brake	
	58900-031	250 Ackermann Air Brake	
	58900-055	150 Ackermann Hydraulic Brake	
	58900-053	200 Ackermann Hydraulic Brake	
	58900-051	250 Ackermann Hydraulic Brake	
34		RH Lower Steering Knuckle Assembly	1
	58900-036	150 Ackermann Air Brake	
	58900-034	200 Ackermann Air Brake	
	58900-032	250 Ackermann Air Brake	
	58900-056	150 Ackermann Hydraulic Brake	
	58900-054	200 Ackermann Hydraulic Brake	
	58900-052	250 Ackermann Hydraulic Brake	
35	60903-055	LH Upper Steering Knuckle Assembly	1
36	60904-002	RH Upper Steering Knuckle Assembly	1
	60961-040	Kingpin Bushing and Bearing Service Kit, Axle Set (Includes Kit Nos. 60961-009 & -039)	
	60961-009	LH Kingpin Bushing w/Composite Thrust Bearing Service Kit (Includes Key Nos.37-40, 42-44, Loctite)	
	60961-039	RH Kingpin Bushing w/Roller Thrust Bearing Service Kit (Includes Key Nos.37-39, 41-44, Loctite)	
37	59156-000	Grease Cap Assembly	4
38	58937-000	Retaining Ring	4
39	58909-000	Kingpin Bushing	4

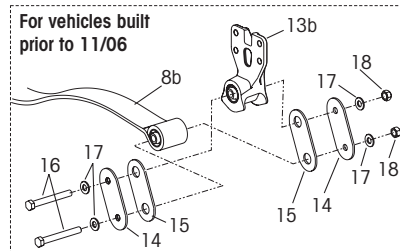
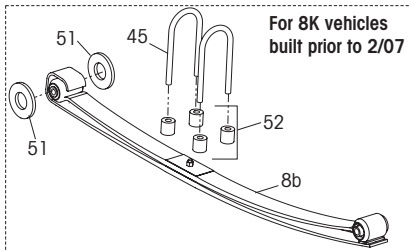
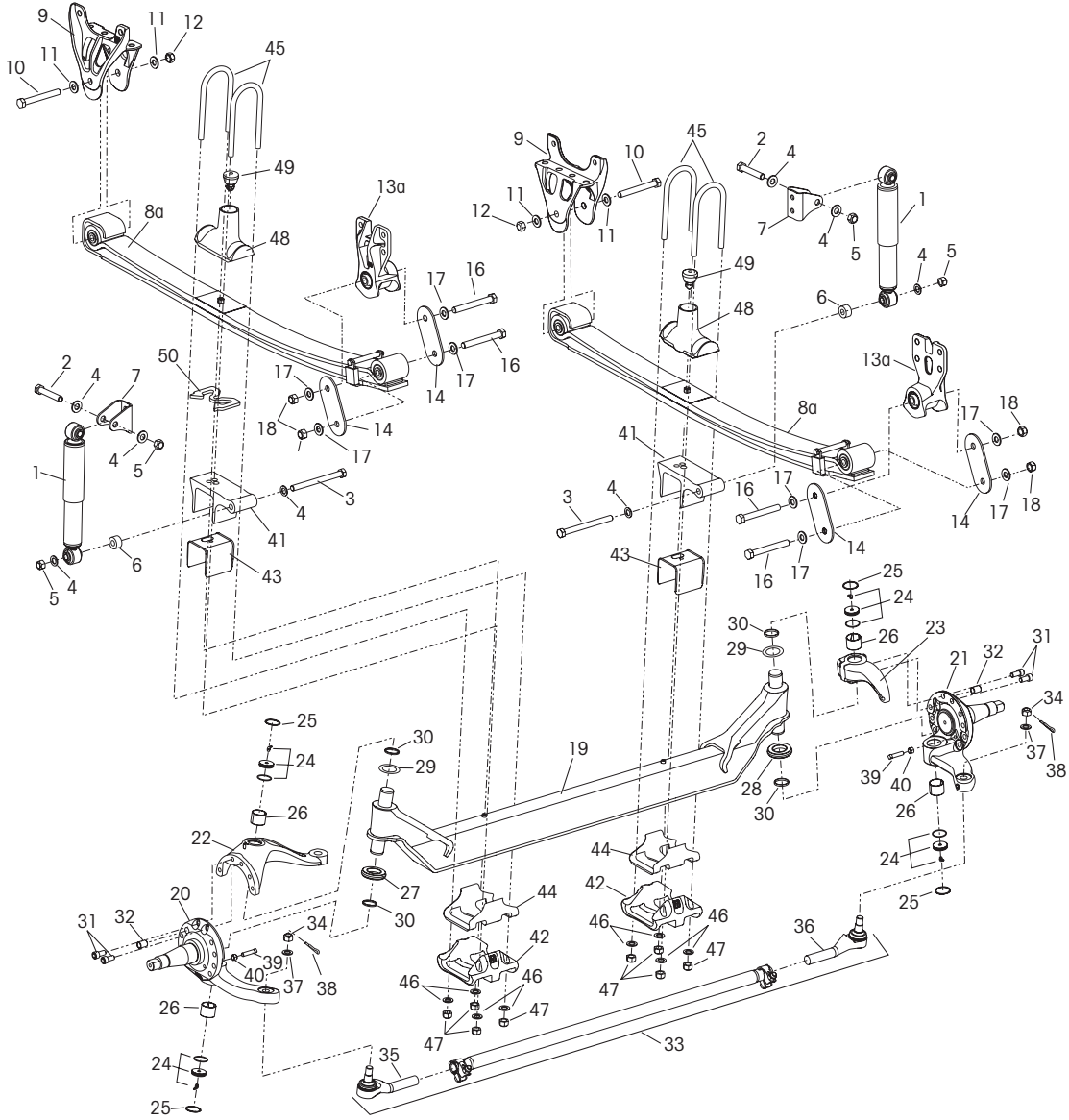
KEY NO.	PART NO.	DESCRIPTION	NO.REQ.
	60961-043	Thrust Bearing Service Kit, Axle Set (Includes Kit Nos. 60961-041 & 60961-042)	
	60961-041	LH Composite Thrust Bearing Service Kit (Includes Key Nos. 40, 42-44, Loctite)	
	60961-042	RH Roller Thrust Bearing Service Kit (Includes Key Nos. 41-43, Loctite)	
40	59828-000	LH Composite Thrust Bearing	1
41	64256-000	RH Roller Thrust Bearing	1
42	60259-002	Kingpin Shim - 0.047"	2
Not Shown	60259-001	Kingpin Shim - 0.005" (As needed for service)	
43	58910-000	Kingpin Seal	4
44	60236-001	5/8"-11 UNC Socket Head Cap Screw	4
Not Shown	60937-000	Loctite (Red) Compound Tube	1
45	64246-000	ABS Sensor Sleeve	2
46		**Tie Rod Assembly, 14.6K, 5.36 Drop (Includes Key Nos. 47-51)	1
	64006-002	150/200 Ackermann	
	64006-003	250 Ackermann	
47		*7/8" Castle Nut	2
	60961-011	Tie Rod End Service Kit, Axle Set (Includes Kit Nos. 60961-027 & -028)	
	60961-027	LH Tie Rod End Service Kit (Includes Key Nos. 48, 50-51)	
	60961-028	RH Tie Rod End Service Kit (Includes Key Nos. 49-51)	
48	64002-001	LH Tie Rod End	1
49	64002-002	RH Tie Rod End	1
50	22962-007	7/8" Flat Washer	2
51	17800-004	Tie Rod Nut Cotter Pin	2
	60961-069	Stop Bolt Service Kit, One Side (Includes Key Nos. 52-53)	
52	60238-001	1/2"-13 UNC Square Head Bolt	2
53	60240-000	1/2"-13 UNC Hex Jam Nut	2
54	59952-026	Top Axle Wrap	2
55	64722-003	Bottom Axle Wrap	2
	60961-015	Top/Bottom Axle Wrap Liner Service Kit, One Side (Includes Key Nos. 56-57)	
56	60508-000	Top Axle Wrap Liner	2
57	59845-000	Bottom Axle Wrap Liner	2
		Clamp Group Service Kit, One side (Includes Key Nos. 58-60)	
	60961-051	6.8" Ride Height	
	60961-146	7.8" Ride Height	
	60961-052	8.8" Ride Height	
	60961-147	9.8" Ride Height	
58		3/4"-16 UNC Hex bolt	8
	21867-044	6.8" Ride Height - 10.0"	
	21867-027	7.8" Ride Height - 11.0"	
	21867-045	8.8" Ride Height - 12.0"	
	21867-035	9.8" Ride Height - 13.0"	
59	22962-001	3/4" Flat Washer	8
60	17700-035	3/4"-16 UNC 2B Nylon Locknut	8
61		Dowel Pin	
		6.8" Ride Height	None Req.
	18831-022	7.8" Ride Height - 1.13"	2
	18831-021	8.8" Ride Height - 2.0"	2
	18831-023	9.8" Ride Height - 3.0"	2
62		Top Pad	
	66814-001	LH	1
	66814-002	RH	1
63		LH/RH Front Axle Spacer	
		6.8" Ride Height	None Req.
	64536-025	7.8" Ride Height	2
	64536-050	8.8" Ride Height	2
	64536-075	9.8" Ride Height	2





Blue Bird Vision Buses - 8K/10K Capacity

84





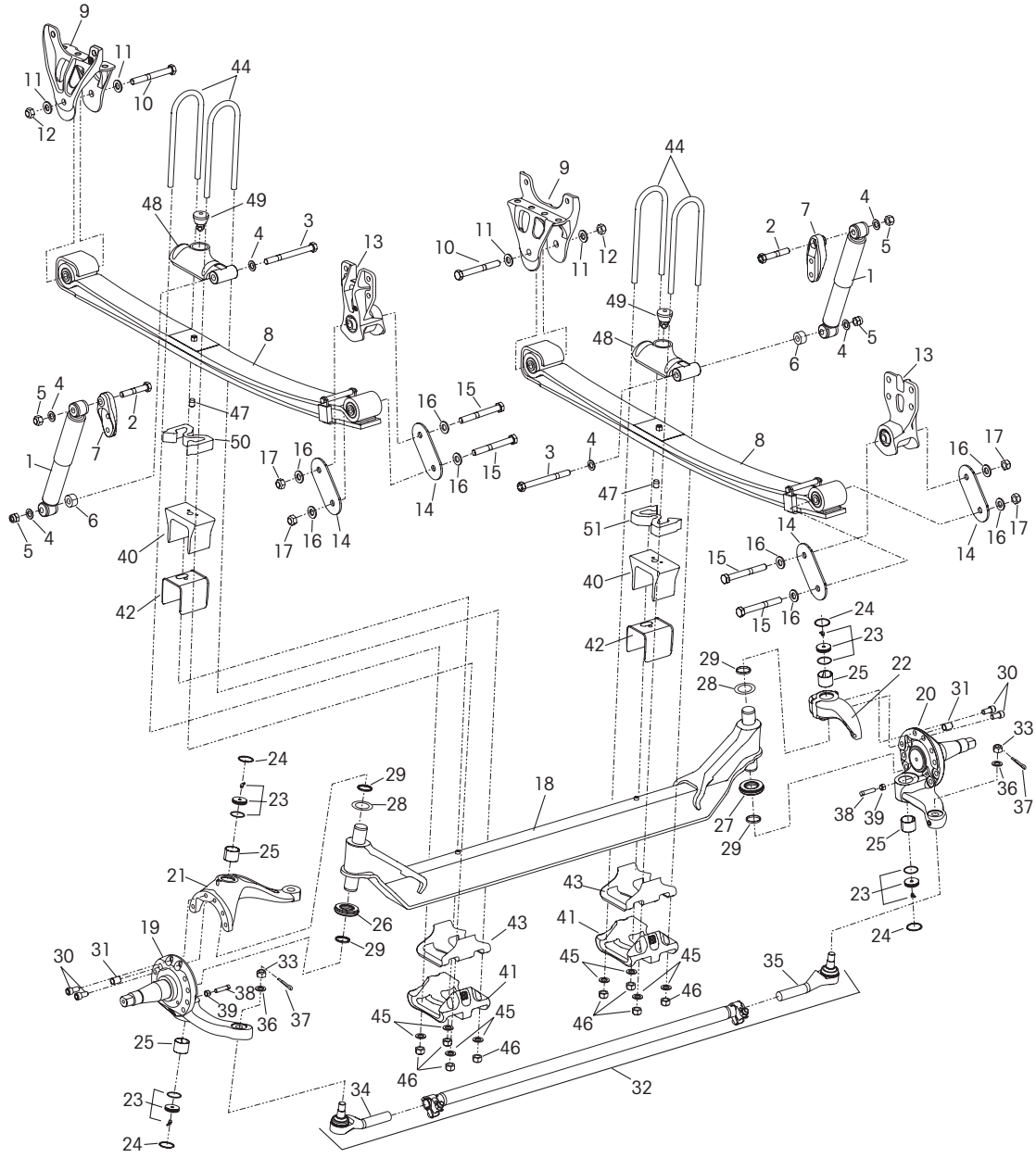
SOFTEK® for Blue Bird Vision Buses - 8K/10K

KEY NO.	PART NO.	DESCRIPTION	NO.REQ.
1	58913-009L	Shock Absorber (Replaces 58913-007)	2
2		**3/4"-10 UNC Upper Shock Bolt	2
3		**3/4"-10 UNC Lower Shock Bolt	2
4		**3/4" Hardened Washer	4
5		**3/4"-10 UNC Hex Locknut	8
6	59946-001	Shock Spacer	2
7	59423-002	Shock Bracket	2
		Leaf Spring Assembly Service Kit <i>For vehicles built after 11/06</i> (Includes Key Nos. 8a, 13a, 14)	
	60961-161	8K	
	60961-162	10K	
		Leaf Spring Assembly	2
8a		<i>For vehicles built after 11/06</i>	
	66623-001	8K	
	66624-001	10K	
8b		<i>For vehicles built prior to 11/06</i>	
	66364-000	8K	
	60511-000	10K	
9	64488-000	Front Hanger	2
10		**M20 Hex Bolt - 170mm	2
11		**M20 Hardened Washer	4
12		**M20 Locknut	2
		Rear Shackle Bracket	2
13a	66510-001	<i>For vehicles built after 11/06</i>	
13b	64316-000	<i>For vehicles built prior to 11/06</i>	
14	64314-000	Rear Shackle Plate	4
15	64159-000	Thrust Washer <i>Only for vehicles built prior to 11/06</i>	4
		**M20 Hex Bolt - 150mm	4
		**M20 Hardened Washer	8
		**M20 Locknut	4
	60952-XXX	STEERTEK Axle Assembly Contact Hendrickson Tech Serv. for Part No. (Includes Key Nos. 19-42)	1
19	64905-004	Axle & Kingpin Assembly 6.5", 8.5" Ride Height	1
20		LH Lower Steering Knuckle Assembly	1
	58900-035	150 Ackermann Air Brake	
	58900-033	200 Ackermann Air Brake	
	58900-031	250 Ackermann Air Brake	
	58900-055	150 Ackermann Hydraulic Brake	
	58900-053	200 Ackermann Hydraulic Brake	
	58900-051	250 Ackermann Hydraulic Brake	
21		RH Lower Steering Knuckle Assembly	1
	58900-036	150 Ackermann Air Brake	
	58900-034	200 Ackermann Air Brake	
	58900-032	250 Ackermann Air Brake	
	58900-056	150 Ackermann Hydraulic Brake	
	58900-054	200 Ackermann Hydraulic Brake	
	58900-052	250 Ackermann Hydraulic Brake	
22	60903-016	LH Upper Steering Knuckle Assembly	1
23	60904-002	RH Upper Steering Knuckle Assembly	1
	60961-040	Kingpin Bushing and Bearing Service Kit, Axle Set (Includes Kit Nos. 60961-009 & -039)	
	60961-009	LH Kingpin Bushing w/Composite Thrust Bearing Service Kit (Includes Key Nos. 24-27, 29-31, Loctite)	
	60961-039	RH Kingpin Bushing w/Roller Thrust Bearing Service Kit (Includes Key Nos. 24-26, 28-31, Loctite)	
24	59156-000	Grease Cap Assembly	4
25	58937-000	Retaining Ring	4
26	58909-000	Kingpin Bushing	4

KEY NO.	PART NO.	DESCRIPTION	NO.REQ.
	60961-043	Thrust Bearing Service Kit, Axle Set (Includes Kit Nos. 60961-041 & -042)	
	60961-041	LH Composite Thrust Bearing Service Kit (Includes Key Nos. 27, 29-31, Loctite)	
	60961-042	RH Roller Thrust Bearing Service Kit (Includes Key Nos. 28-31, Loctite)	
27	59828-000	LH Composite Thrust Bearing	1
28	64256-000	RH Roller Thrust Bearing	1
29	60259-002	Kingpin Shim - 0.047"	2
Not Shown	60259-001	Kingpin Shim - 0.005" (As needed for service)	
30	58910-000	Kingpin Seal	4
31	60236-001	5/8"-11 UNC Socket Head Cap Screw	4
Not Shown	60937-000	Loctite (Red) Compound Tube	1
32	64246-000	ABS Sensor Sleeve	2
33		***Tie Rod Assembly, 10K, 5.36 Drop (Includes Key Nos. 34-38)	1
	66699-003	200 Ackermann (Replaces 59948-005)	
	66699-001	250 Ackermann (Replaces 59948-006)	
34		3/8" Castle Nut	2
	60961-139	*** Tie Rod End Service Kit, Axle Set (Replaces 60961-012) (Includes Kit Nos. 60961-137 & -138)	
	60961-137	*** LH Tie Rod End Service Kit (Replaces 60961-029) (Includes Key Nos. 35, 37-38)	
	60961-138	*** RH Tie Rod End Service Kit (Replaces 60961-030) (Includes Key Nos. 36-38)	
35	66645-001	***LH Tie Rod End (Replaces 64004-001)	1
36	66645-002	***RH Tie Rod End (Replaces 64004-002)	1
37	22962-007	7/8" Flat Washer	2
38	17800-004	Tie Rod Nut Cotter Pin	2
	60961-069	Stop Bolt Service Kit, Axle Set (Includes Key Nos. 39-40)	
39	60238-001	1/2"-13 UNC Square Head Bolt	2
40	60240-000	1/2"-13 UNC Hex Jam Nut	2
41	59952-003	Top Axle Wrap	2
42	64722-003	Bottom Axle Wrap	2
	60961-015	Top/Bottom Axle Wrap Liner Service Kit, One Side (Includes Key Nos. 43-44)	
43	60508-000	Top Axle Wrap Liner	2
44	59845-000	Bottom Axle Wrap Liner	2
		Clamp Group Service Kit, One side (Includes Key Nos. 45-47)	
	60961-140	6.5" Ride Height	
	60961-141	8.5" Ride Height	
45		3/4"-16 UNC U-bolt	4
	64804-110	6.5" Ride Height - 11.0"	
	64804-130	8.5" Ride Height - 13.0"	
46	22962-001	3/4" Flat Washer	8
47	17700-035	3/4"-16 UNC 2B Nylon Locknut	8
Not Shown	18831-021	Dowel Pin, 8.5" Ride Height - 2.0"	1
	64506-000	Top Pad/Axle Stop Assembly (Includes Key Nos. 48-49)	
48	64519-000	Top Pad	2
49	64080-000	Rubber Axle Stop	2
50		Front Axle Spacer	
	64536-010	LH 6.5" Ride Height	1
	64536-060	LH 8.5" Ride Height	1
Not Shown	64536-050	RH 8.5" Ride Height	1
51	66164-000	Thrust Pad Washer - 8K	2
52	66366-001	Clamp Group Spacer - 8K	4



Blue Bird All American Buses - 13.2K/14.6K Capacity





SOFTEK® for Blue Bird All American Buses - 13.2K/14.6K

KEY NO.	PART NO.	DESCRIPTION	NO.REQ.	KEY NO.	PART NO.	DESCRIPTION	NO.REQ.
1	58913-010L	Shock Absorber	2	32		Tie Rod Assembly, 14.6K, 5.36 Drop (Includes Key Nos. 33-37)	1
2		**3/4"-10 UNC Upper Shock Bolt	2		64006-002	150/200 Ackermann	
3		**3/4"-10 UNC Lower Shock Bolt	2		64006-003	250 Ackermann	
4		**3/4" Hardened Washer	4	33		*3/4" Castle Nut	2
5		**3/4"-10 UNC Hex Locknut	6		60961-011	Tie Rod End Service Kit, Axle Set (Includes Kit Nos. 60961-027 & -028)	
6	59946-001	Shock Spacer	2		60961-027	LH Tie Rod End Service Kit (Includes Key Nos. 34, 36-37)	
7	65000-002	Shock Bracket	2		60961-028	RH Tie Rod End Service Kit (Includes Key Nos. 35-37)	
8		Leaf Spring Assembly	2	34	64002-001	LH Tie Rod End	1
	66625-001	13.2K		35	64002-002	RH Tie Rod End	1
	66626-001	14.6K		36	22962-007	3/8" Flat Washer	2
9	64488-002	Front Hanger	2	37	17800-004	Tie Rod Nut Cotter Pin	2
10		**M20 Hex Bolt - 170mm	2		60961-069	Stop Bolt Service Kit, Axle Set (Includes Key Nos. 38-39)	
11		**M20 Hardened Washer	4	38	60238-001	1/2"-13 UNC Square Head Bolt	2
12		**M20 Locknut	2	39	60240-000	1/2"-13 UNC Hex Jam Nut	2
13	66510-001	Rear Shackle Bracket	2	40	59952-026	Top Axle Wrap	2
14	64314-000	Rear Shackle Plate	4	41	64722-003	Bottom Axle Wrap	2
15		**M20 Hex Bolt - 150mm	4		60961-015	Top/Bottom Axle Wrap Liner Service Kit, One Side (Includes Key Nos. 42-43)	
16		**M20 Hardened Washer	8	42	60508-000	Top Axle Wrap Liner	2
17		**M20 Locknut	4	43	59845-000	Bottom Axle Wrap Liner	2
	60952-XXX	STEERTEK Axle Assembly Contact Hendrickson Tech Serv. for Part No. (Includes Key Nos. 19-43)	1			Clamp Group Service Kit, One side (Includes Key Nos. 44-47)	
18	64905-005	Axle & Kingpin Assembly 6.8", 7.8", 8.8" and 9.8" Ride height	1		60961-142	6.8" Ride Height	
19		LH Lower Steering Knuckle Assembly	1		60961-143	7.8" Ride Height	
	58900-035	150 Ackermann Air Brake			60961-144	8.8" Ride Height	
	58900-033	200 Ackermann Air Brake			60961-145	9.8" Ride Height	
	58900-031	250 Ackermann Air Brake		44		3/4"-16 UNC U-bolt	4
	58900-055	150 Ackermann Hydraulic Brake			64804-120	6.8" Ride Height - 12.0"	
	58900-053	200 Ackermann Hydraulic Brake			64804-130	7.8" Ride Height - 13.0"	
	58900-051	250 Ackermann Hydraulic Brake			64804-140	8.8" Ride Height - 14.0"	
20		RH Lower Steering Knuckle Assembly	1		64804-150	9.8" Ride Height - 15.0"	
	58900-036	150 Ackermann Air Brake		45	22962-001	3/4" Flat Washer	8
	58900-034	200 Ackermann Air Brake		46	17700-035	3/4"-16 UNC 2B Nylon Locknut	8
	58900-032	250 Ackermann Air Brake		47		Dowel Pin	
	58900-056	150 Ackermann Hydraulic Brake			18831-022	6.8" Ride Height	None Req.
	58900-054	200 Ackermann Hydraulic Brake			18831-021	7.8" Ride Height - 1.13"	2
	58900-052	250 Ackermann Hydraulic Brake			18831-021	8.8" Ride Height - 2.0"	2
21	60903-055	LH Upper Steering Knuckle Assembly	1		18831-023	9.8" Ride Height - 3.0"	2
22	60904-002	RH Upper Steering Knuckle Assembly	1		66806-000	Top Pad/Axle Stop Assembly (Includes Key Nos. 48-49)	
	60961-040	Kingpin Bushing and Bearing Service Kit, Axle Set (Includes Kit Nos. 60961-009 & -039)		48	66666-000	Top Pad	2
	60961-009	LH Kingpin Bushing w/Composite Thrust Bearing Service Kit (Includes Key Nos. 23-26, 28-30, Loctite)		49	64080-000	Rubber Axle Stop	2
	60961-039	RH Kingpin Bushing w/Roller Thrust Bearing Service Kit (Includes Key Nos. 23-25, 27-30, Loctite)		50		LH Front Axle Spacer	1
23	59156-000	Grease Cap Assembly	4		64536-010	6.8" Ride Height	
24	58937-000	Retaining Ring	4		64536-035	7.8" Ride Height	
25	58909-000	Kingpin Bushing	4		64536-060	8.8" Ride Height	
	60961-043	Thrust Bearing Service Kit, Axle Set (Includes Kit Nos. 60961-041 & -042)			64536-085	9.8" Ride Height	
	60961-041	LH Composite Thrust Bearing Service Kit (Includes Key Nos. 26, 28-30, Loctite)		51		RH Front Axle Spacer	1
	60961-042	RH Roller Thrust Bearing Service Kit (Includes Key Nos. 27-30, Loctite)			64536-025	6.8" Ride Height	None Req.
26	59828-000	LH Composite Thrust Bearing	1		64536-050	7.8" Ride Height	
27	64256-000	RH Roller Thrust Bearing	1		64536-075	8.8" Ride Height	
28	60259-002	Kingpin Shim - 0.047"	2			9.8" Ride Height	
Not Shown	60259-001	Kingpin Shim - 0.005" (As needed for service)					
29	58910-000	Kingpin Seal	4				
30	60236-001	5/8"-11 UNC Socket Head Cap Screw	4				
Not Shown	60937-000	Loctite (Red) Compound Tube	1				
31	64246-000	ABS Sensor Sleeve	2				

AIRTEK® • SOFTEK® for Blue Bird Buses



AIRTEK — SERVICE KITS QUICK REFERENCE

	Height Control Valve Service Kit
64741-008	Vision
59013-000	All American
64742-001	Link Mount Service Kit
60961-040	Kingpin Bushing and Bearing Service Kit, Axle Set
60961-009	LH Kingpin Bushing w/Composite Thrust Bearing Service Kit
60961-039	RH Kingpin Bushing w/Steel Roller Bearing Service Kit
60961-043	Thrust Bearing Service Kit, Axle Set
60961-041	LH Composite Thrust Bearing Service Kit
60961-042	RH Roller Thrust Bearing Service Kit
	***Tie Rod End Service Kit, Axle Set
60961-139	Vision
60961-011	All American
	***LH Tie Rod End Service Kit
60961-157	Vision
60961-027	All American
	***RH Tie Rod End Service Kit
60961-138	Vision
60961-028	All American
60961-069	Stop Bolt Service Kit
	Clamp Group Service Kit (One side only)
	Vision
60961-051	6.5" Ride Height
60961-052	8.5" Ride Height
	All American
60961-051	6.8" Ride Height
60961-146	7.8" Ride Height
60961-052	8.8" Ride Height
60961-147	9.8" Ride Height
60961-015	Top/Bottom Axle Wrap Liner Service Kit
60961-163	Leaf Spring Assembly Service Kit
	<i>(For vehicles built prior to 11/06)</i>

SOFTEK — SERVICE KITS QUICK REFERENCE

60961-040	Kingpin Bushing and Bearing Service Kit Axle Set
60961-009	LH Kingpin Bushing w/Composite Thrust Bearing Service Kit
60961-039	RH Kingpin Bushing w/Roller Thrust Bearing Service Kit
60961-043	Thrust Bearing Service Kit, Axle Set
60961-041	Composite Thrust Bearing Service Kit
60961-042	Roller Thrust Bearing Service Kit
	***Tie Rod End Service Kit, Axle Set
60961-139	Vision
60961-011	All American
	***LH Tie Rod End Service Kit
60961-137	Vision
60961-027	All American
	***RH Tie Rod End Service Kit
60961-138	Vision
60961-028	All American
60961-069	Stop Bolt Service Kit
	Clamp Group Service Kit
	Vision
60961-140	6.5" Ride Height
60961-141	8.5" Ride Height
	All American
60961-142	6.8" Ride Height
60961-143	7.8" Ride Height
60961-144	8.8" Ride Height
60961-145	9.8" Ride Height
60961-015	Top/Bottom Axle Wrap Liner Service Kit
	Leaf Spring Assembly Service Kit
	<i>For vehicles built prior to 11/06</i>
60961-161	8K
60961-162	10K

NOTE :

- * Item included in assembly only, part not sold separately.
- ** Not supplied by Hendrickson, used for reference only. Refer to the OEM (vehicle manufacturer) for more information. Hendrickson is not responsible for components supplied by vehicle manufacturer. For assistance with maintenance and rebuild instructions on these components see vehicle manufacturer.
- *** Hendrickson supplies different tie rod assemblies and each type may take a different replacement tie rod end kit to service. Prior to ordering, find the part number on the tie rod tube, see Hendrickson Publication No. SEU-0223 or contact Hendrickson Sales Engineering 630.910.2800 for corresponding kit numbers.



SECTION 6

On Highway and On Roadway Recommended Towing Procedure

Hendrickson recommends that a vehicle equipped with a STEERTEK axle be towed by the following methods (listed in order of preference) for ON HIGHWAY or ON ROADWAY applications.

1. Wheel lift method, the ideal towing procedure
2. Towing the vehicle from the rear method
3. Conventional axle fork method

Please read, understand and comply with any additional towing instructions and safety precautions that may be provided by the vehicle manufacturer.

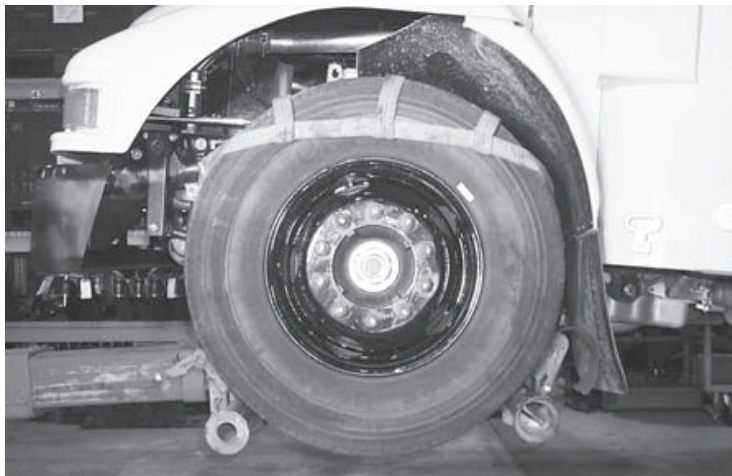
Hendrickson will not be responsible for any damage to the axle, suspension or other vehicle components resulting from any towing method or fixture not authorized by Hendrickson.

Please contact Hendrickson Tech Services at 630.910.2800 or send email to: techservices@hendrickson-intl.com with any questions regarding proper towing procedures for vehicles equipped with a STEERTEK axle.

WHEEL LIFT METHOD—IDEAL

This method provides the greatest ease for towing the vehicle. Lifting at the tires helps reduce the risk of possible damage to the axle, suspension, and engine components during towing operations, see Figure 6-1.

FIGURE 6-1 WHEEL LIFT METHOD



AIRTEK® • SOFTEK® for Blue Bird Buses



TOWING VEHICLE FROM THE REAR METHOD

This method is preferred when the proper equipment is not available to perform the wheel lift method and is necessary for wreckers not equipped with an under lift system.

AXLE FORK LIFT METHOD

This is an alternative method for towing the vehicle, but requires standard 5" forks, (see Figures 6-2 and 6-3) and designated lift points inside the axle clamp groups. The following procedure must be used:

- Place a spacer on the boom, to provide adequate clearance between the oil pan and the boom if necessary. Lift the vehicle in order to place spacer under tires. This will provide sufficient room under the axle to locate forks in the proper position.
- Install the fork in the boom properly.
- Position the tow forks directly under the axle, inside the axle clamp groups as shown in Figure 6-2.

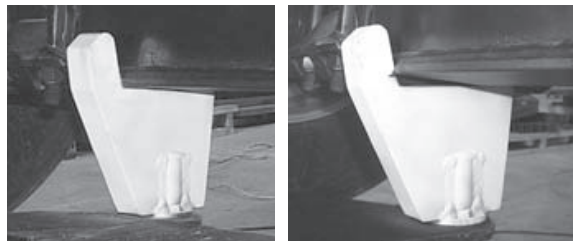
FIGURES 6-2 AND 6-3
PROPER TOW FORK LOCATION ON INSIDE CLAMP GROUP ON THE STEERTEK AXLE



- Prior to lifting the vehicle, ensure that the bottom axle plate is flat in the tow fork to minimize any gap between the bottom axle plate and the tow fork, see Figure 6-4 and 6-5. It may be necessary to deflate the air in the steer axle suspension, and/or release the tractor brakes. Deflate the steer axle air springs by disconnecting the height control valve linkage and lowering the height control valve linkage arm. This will exhaust the air pressure in the steer axle air springs.

FIGURE 6-4 WITHOUT GAP

FIGURE 6-5 WITH GAP



NOTE

When lifting a vehicle with an under lift boom, care must be taken not to damage the engine's oil pan. Vehicles equipped with a front fairing may require removal of the front fairing prior to towing to prevent component damage.



AIRTEK®• SOFTEK® for Blue Bird Buses

- Lift vehicle and secure the vehicle to the boom.
- Install safety straps, it is preferred to use nylon safety straps. Chains have a tendency to bind and may cause damage to the axle.

OFF ROADWAY TOWING METHOD

WARNING

WHEN A VEHICLE IS DISABLED AND EQUIPPED WITH A STEERTEK AXLE, CARE MUST BE TAKEN TO ENSURE THERE IS NO DAMAGE TO THE SUSPENSION OR AXLE WHEN TOWING THE VEHICLE. THE USE OF A TOW STRAP IS NECESSARY TO TOW A DISABLED VEHICLE INTO A REPAIR FACILITY PARKING LOT INTO THE SHOP BAY. THE TOW STRAPS SHOULD BE CONNECTED TO THE TOW HOOKS PROVIDED BY THE VEHICLE MANUFACTURER AT THE FRONT OF THE BUMPER. IF THE USE OF TOW HOOKS IS NOT AN OPTION THEN A TOW STRAP MAY BE WRAPPED AROUND THE FRONT AXLE, (SEE FIGURE 6-6) IN A MANNER THAT IS ACCEPTABLE FOR TOWING THE VEHICLE INTO THE SHOP. DO NOT USE A TOW CHAIN AROUND THE FRONT AXLE TO TOW THE VEHICLE, DOING SO WILL DAMAGE THE AXLE AND VOID WARRANTY, (SEE FIGURE 6-7).

THE FOLLOWING METHODS ARE NOT RECOMMENDED FOR:
ON HIGHWAY OR ON ROADWAY TOWING

FIGURE 6-6

NYLON STRAPS ARE
ACCEPTABLE FOR
OFF ROADWAY TOWING



FIGURE 6-7

CHAINS ARE NOT
ACCEPTABLE FOR
OFF ROADWAY TOWING







SECTION 7
Preventive Maintenance

VISUAL INSPECTION

The AIRTEK and SOFTEK are low maintenance suspension and axle systems. However it is necessary to visually inspect the following items every six months or 25,000 miles (40,000 km), whichever comes first, to help ensure all such components function to their highest efficiency.

- **Wear and Damage** — Inspect all parts of suspension for wear and damage. Look for bent or cracked parts. Replace all worn or damaged parts.
- **Air Spring** — Look for chaffing or any signs of spring or component damage.
- **Fasteners** — Look for any loose or damaged fasteners on the entire suspension. Make sure all fasteners are tightened to the specified torque. Refer to  Tightening Torque Specifications in the appendix. Use a calibrated torque wrench to check torque in a tightening direction. As soon as the fastener starts to move, record the torque. Correct the torque if necessary. Replace any worn or damaged fasteners.
- **Thrust Washers (If equipped)** — Look for any signs of excessive wear to the thrust washers, shackles and shackle bracket. See Thrust Washer Inspection detailed in this section.
- **STEERTEK Axle** — The axle should be free of any nicks or gouges. Inspect for any cracks or dents on axle.
- **Shock Absorber** — Look for any signs of dents or leakage, misting is not considered a leak. See Shock Absorber Inspection in this section.
- **Clamp Group** — Check torque on clamp group mounting hardware. Refer to  Tightening Torque Specifications in the appendix of this publication.
- **Top and Bottom Axle Wrap Liners** — Look for any cracking or broken pieces on liner in load bearing areas. See Axle Wrap Liner Inspection in this section.
- **Steel Leaf Spring and Wrap Leaf Assembly** — Look for cracks. Check the front and rear bushings for any wear or deterioration. Replace spring assembly if any of the previous conditions are observed. See the Component Replacement Section of this publication for replacement procedure.
- **Front Hangers and Shackle Brackets** — Check for cracks or loose mounting hardware. Replace if necessary, see the Component Replacement Section of this publication for replacement procedure.
- **Top Pad (AIRTEK)** — Check for cracks or damage. Replace if necessary, see the Component Replacement Section of this publication for replacement procedure.
- **Top Pad and Bump Stop (SOFTEK)** — Check for cracks and/or missing rubber bump stops. Replace if necessary, see the Component Replacement Section of this publication for replacement procedure.
- **Steering Pivot Points** — Check for looseness at all pivot points. Inspect and lubricate all pivot points. Refer to the Trouble Shooting Guide Section in the Appendix of this publication.
- **Operation** — All steering components must move freely through the full range of motion from axle stop to axle stop.
- **Tire Wear** — Inspect tires for wear patterns that may indicate suspension damage or misalignment. See Tire Inspection in this section.
- See vehicle manufacturer’s applicable publications for other preventative maintenance requirements.





AIRTEK® • SOFTEK® for Blue Bird Buses

LUBRICATION INTERVALS

For vehicles equipped with the STEERTEK axle, regular lubrication intervals should be followed to help prevent premature wear to the kingpin bushings and tie rod ends, see lubrication chart below.

STEERTEK GREASING AND LUBRICATION SPECIFICATIONS				
Component	Greasing Interval	Grease	NLGI Grade	Outside Temperature
Kinpin Bushings	Maximum of 25,000 miles (40,225 kilometers) or 90 days, whichever comes first.	Multipurpose Grease	2	Refer to the lubricant manufacturer's specifications for the temperature service limits applicable to your area.
Tie Rod Ends				
Drag Link	See Vehicle Manufacturer			
NOTE: Lubrication greases acceptable for use on the STEERTEK axle will carry a designation of NLGI #2 EP and rated GC-LB or equivalent.				

KINGPIN LUBRICATION

On the Hendrickson STEERTEK front axle the kingpin grease fittings are located on the top and bottom of the kingpin grease caps.

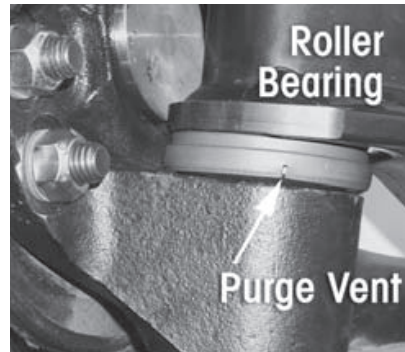
1. Place the vehicle on a level floor.
2. Prior to greasing the kingpins on the vehicle, the suspension must be in a loaded condition.
3. Clean off all the grease fittings and grease gun tip with a clean shop towel prior to lubrication.
4. Lubricate the kingpins through the grease fittings on the top and bottom of the steering knuckle, see Lubrication Specification Matrix above.
5. Force the required lubricant into the upper and lower kingpin grease fittings, until new lubricant flows from the upper axle beam and knuckle and the thrust bearing purge location, see Figure 7-1 and Figure 7-2.

NOTE Greasing at the lower zerk should purge grease from the thrust bearing shell. The left side of the axle has a composite style thrust bearing (See Figure 7-1) and the right side of the axle has a steel roller thrust bearing (See Figure 7-2). Both purge in the same area.

FIGURE 7-1



FIGURE 7-2





TIE ROD END LUBRICATION

LUBRICATION PROCEDURE

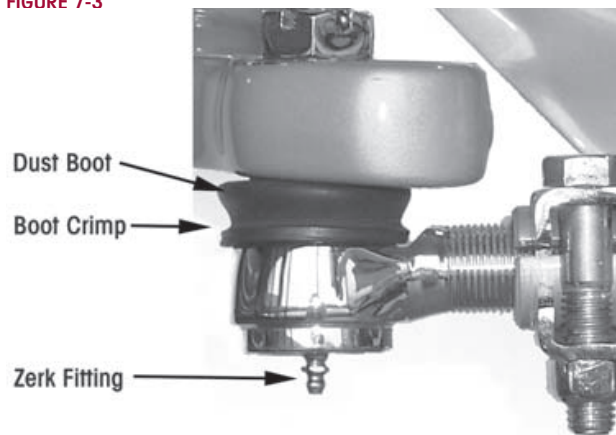
1. Turn the vehicle wheels straight ahead.
2. Wipe the zerk fitting and grease gun tip with clean shop towels.
3. Wipe the seal/boot clean with shop towels.
4. Attach a grease gun to the zerk fitting. Either a hand or pneumatic grease gun is acceptable. If air operated grease gun is used, system air pressure should not exceed 150 psi (1035 kPa).

CAUTION

EXCEEDING THE MAXIMUM AIR PRESSURE TO THE ZERK FITTING CAN CAUSE DAMAGE TO THE DUST BOOT AND COMPONENT FAILURE.

5. Dirt, water, and discolored old grease should flow from the relief vents or purge holes near the boot crimp or bellows area, see Figure 7-3. Continue to purge grease until fresh grease flows from the purge area.

FIGURE 7-3



6. If the tie rod end is designed for lube service and it will not accept grease proceed as follows:
 - a. Remove the zerk fitting
 - b. Inspect the threaded zerk fitting hole in the tie rod end and remove any obstructions
 - c. Install a new zerk fitting
 - d. Continue the lubrication procedure
 - e. If the tie rod end will not accept grease following this procedure it will be necessary to replace the tie rod end, (see Tie Rod End replacement in the Component Replacement Section of this publication)
7. Apply grease until all the old grease is purged from the boot and fresh grease is coming out.



AIRTEK®• SOFTEK® for Blue Bird Buses

95

TIE ROD END INSPECTION

INSPECTION PROCEDURE

Before beginning this inspection procedure, the entire system must be unloaded (i.e., the front end of the vehicle must be raised and supported with safety stands).

CAUTION

DO NOT GREASE THE TIE ROD ASSEMBLY BEFORE PERFORMING THE INSPECTION. DOING SO CAN INHIBIT EFFORTS TO DETERMINE ACTUAL WEAR.

CAUTION

REPLACE THE ENTIRE TIE ROD END IF THE BOOT IS TORN OR MISSING, FAILURE TO DO SO CAN CAUSE PREMATURE WEAR OF THE TIE ROD END.

1. Block rear wheels of vehicle. Using the bottom of the axle beam or the frame rails, raise the front end off the ground and support with stands.
2. With the engine off, turn the wheels from full left to full right and then return to the straight-ahead position.
3. Check that the boots are in place and completely installed over the tie rod ends.
4. Check for cracking or tears in the boots. Also check the boot seals for damage. Replace the entire tie rod end if the boot is damaged.

WARNING

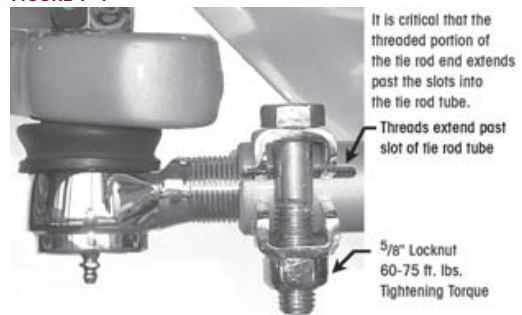
THE CORRECT COTTER PIN MUST BE INSTALLED THROUGH THE TIE ROD END WITH THE CASTLE NUT TIGHTENED TO THE PROPER TORQUE SPECIFICATION IN ORDER TO SECURELY ATTACH THE TIE ROD. LOSS OF THE COTTER PIN CAN CAUSE THE TIE ROD END NUT TO BECOME LOOSE AND ADVERSELY AFFECT VEHICLE STEERING AND POSSIBLY RESULT IN TOTAL LOSS OF STEERING CONTROL.

5. Check that the tie rod end nut is installed and secured with a cotter pin. If the cotter pin is missing, check the nut torque specification and then install a new cotter pin. Always tighten the castle nut to specified torque when setting the cotter pin. Do not back off the nut to insert cotter pin.

6. Check that the tie rod end is threaded correctly into the cross tube and is engaged deeper than the end of the cross tube slot. The tie rod end must be visible the entire length of the cross tube slot. See Figure 7-4.

7. Check that zerk fittings are installed. Replace a damaged zerk fitting with a new one.

FIGURE 7-4



CAUTION

DO NOT USE THE FOLLOWING ITEMS OR METHODS TO CHECK FOR MOVEMENT OF THE TIE ROD ASSEMBLY. DAMAGE TO COMPONENTS CAN RESULT IF:

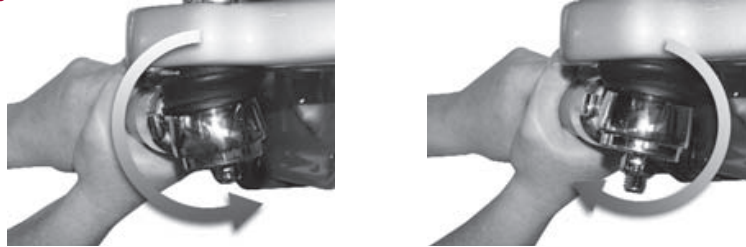
- A CROW BAR, PICKLE FORK OR 2 x 4 ARE USED.
- ANYTHING OTHER THAN HANDS ARE USED TO GRASP THE CROSS TUBE ASSEMBLY (CAN RESULT IN DAMAGE TO THE CROSS TUBE).
- EXCESSIVE PRESSURE OR FORCE IS APPLIED TO THE TIE ROD ENDS OR THE JOINTS OF THE ASSEMBLY.

AIRTEK® • SOFTEK® for Blue Bird Buses



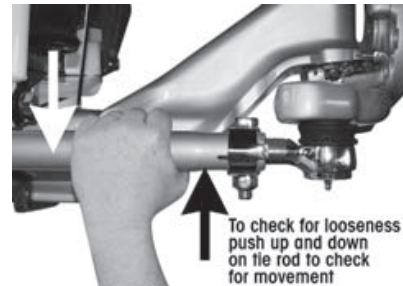
8. By hand or using a pipe wrench, with jaw protectors to avoid gouging the cross tube, rotate the cross tube toward the front of the vehicle and then toward the rear. After rotating, center the cross tube. If the cross tube will not rotate in either direction, replace both tie rod ends. See Figure 7-5.

FIGURE 7-5



9. Position yourself directly below the tie rod end. Using both hands, grab the assembly end as close to the tie rod end as possible (no more than 6" or 152.4mm). Apply hand pressure with reasonable human effort vertically up and down in a push-pull motion several times (using approx. 50-100 lbs. of force). Check for any movement or looseness at both tie rod end locations. See Figure 7-6.

FIGURE 7-6



10. If there is any movement in the tie rod assembly, install a magnetic based dial indicator on the Ackermann arm. See Figure 7-7.
11. Set the dial indicator to zero.
12. Apply hand pressure with reasonable human effort vertically up and down in a push-pull motion several times (using approx. 50-100 lbs. of force). Observe the reading on the dial indicator.
13. If the reading is more than 0.060", replace both tie rod ends at the next service interval.
14. If a tie rod end exhibits 0.125" of movement by hand, the vehicle should be removed immediately from use and the tie rod end be replaced.

FIGURE 7-7



NOTE

According to the Commercial Vehicle Safety Alliance (CVSA), the vehicle "out of service" criteria is: Any motion other than rotational between any linkage member and its attachment point of more than 1/8" (3mm) measured with hand pressure only. (393.209(d)), (published in the North American Standard Out-of-Service Criteria Handbook, April 1, 2006.)



AIRTEK®• SOFTEK® for Blue Bird Buses

CLAMP GROUP RE-TORQUE INTERVAL

1. Clamp group locknuts must be torqued to specification at preparation for delivery.
2. Clamp group locknuts must be re-torqued at 1,000 miles.
3. Thereafter follow the 6 month/ 25,000 mile inspection and annual re-torque interval.
4. Ensure that the clamp group is properly aligned and the hex bolts/U-bolts are seated in the top pad, and the bottom axle wrap is centered on the top axle wrap, see Figures 7-8 and 7-9.

FIGURE 7-8 AIRTEK

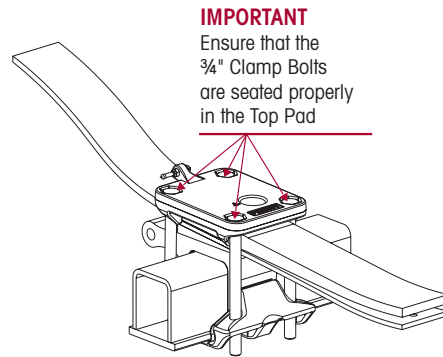
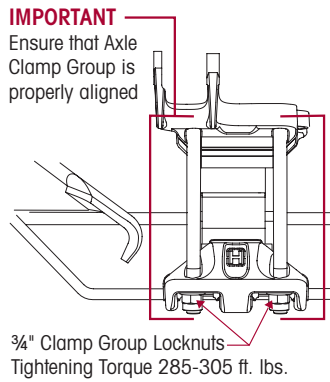
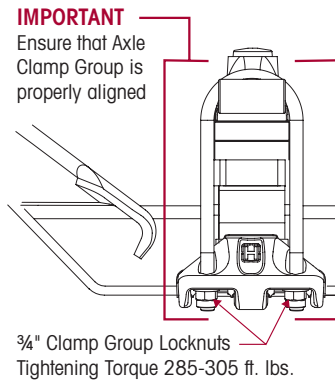
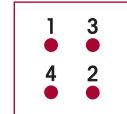


FIGURE 7-9 SOFTEK



5. Check for the signs of component or bolt movement.
6. If signs of movement are present, disassemble the clamp group fasteners, check for component wear or damage and replace as necessary, then install new clamp group fasteners and repeat steps 1 through 5.
7. Tighten the clamp group locknuts evenly in 50 foot pounds increments to 285-305 foot pounds torque in the proper pattern to achieve uniform bolt tension, see Figure 7-10.

FIGURE 7-10





TIRE INSPECTION

The leading causes of tire wear are the following, in order of importance:

1. Tire Pressure
2. Toe Setting
3. Thrust Angle
4. Camber

The following tire inspection guidelines are based upon TMC (Technology & Maintenance Council) recommended practices. Any issues regarding irregular tire wear where Hendrickson is asked for assistance, will require tire and alignment maintenance records, reference TMC's literature numbers RP219A, RP230, or RP 642.

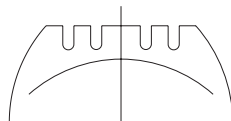
Tire wear is normally the best indicator of vehicle alignment condition. If tires are wearing too rapidly or irregularly, alignment corrections may be needed. The tire wear patterns described below can help isolate specific alignment problems.

The most common conditions of concern are:

- Overall Fast Wear (Miles per 32nd)
- Feather Wear
- Cupping
- Diagonal Wear
- Rapid Shoulder Wear (One Shoulder Only)
- One-Sided Wear

FIGURE 7-11

OVERALL FAST WEAR (Miles per 32nd)

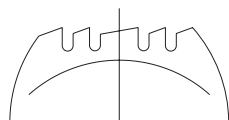


Overall Fast Wear — Fast wear can be described as exhibiting a good, but accelerated wear pattern. It is typically caused by operating conditions, such as mountainous terrain, frequency and severity of turning, abrasive road surfaces in combination with vehicle configurations and their attributes—such as power steering, heavy axle loads, high wheel cuts, setback axles, short wheel base tractors, long wheel base straight trucks. To correct this problem, consult

with vehicle and tire manufacturers when specifying equipment or replacing tires. For more information, see TMC RP 219A publication, page 11. For information on how to accurately measure and record tire rates, see TMC RP 230 publication.

FIGURE 7-12

FEATHER WEAR



Feather wear — Tread ribs or blocks worn so that one side is higher than the other resulting in step-offs across the tread face. Generally, ribs or blocks exhibit this wear. To spot this problem, do the following:

With one hand flat on the tread of the tire and a firm down pressure, slide your hand across the tread of the tire. In one direction, the tire will feel smooth and in the opposite direction there will be a sharp edge to the tread. Typical causes of

feather wear include: excessive side force scrubbing, resulting from conditions of misalignment such as excessive toe, drive axle misalignment, worn, missing or damaged suspension components, bent tie rods or other chassis misalignment.

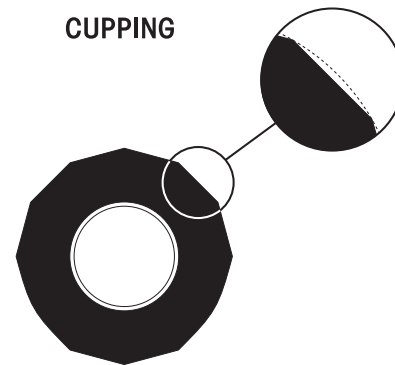


AIRTEK®• SOFTEK® for Blue Bird Buses

To correct this problem, tires can be rotated to another axle for maximum utilization of remaining tread. Additionally, diagnose the vehicle itself and correct misalignment condition as required. If steer tire feathers are in opposite directions, an improper toe condition is most likely the cause. For more information, see TMC RP 219A publication, page 5.

If feather wear on both steer tires is in the same direction, drive axle or other chassis misalignment is indicated. If one steer tire shows feather wear and the other steer tire has normal wear, a combination of toe and drive axle or chassis misalignment is indicated.

FIGURE 7-13



Cupping — Localized, dished out areas of fast wear creating a scalloped appearance around the tire. Cupping, which appears around the tire on the shoulder ribs, may also progress to adjoining ribs, see TMC RP 219A publication, page 7.

Cupping is usually a result of moderate-to-severe imbalance, improper rim/wheel mounting, excessive wheel end play or other assembly non-uniformity. It can also be due to lack of shock absorber control on some suspension types.

To solve cupping problems:

- *Tires* – Correct mismount or balance problem. If ride complaints arise, steer tires may be rotated to drive or trailer axle.
- *Vehicle* – Diagnose component imbalance condition, i.e., wheel, rim, hub, brake, drum. Correct as necessary.

Diagonal Wear — Can be described as localized flat spots worn diagonally across the tread at approximately 25-35° angles, often repeating around the tread circumference. For more information, see TMC RP 219A publication, page 20.

Diagonal wear is usually caused by bad wheel bearings, toe out, mismounting of tire and wheel assembly to axle, and mismatched duals for size and/or inflation pressures. It may start as brake skid. Diagonal wear is aggravated by high speed empty or light load hauls.

To correct diagonal wear, reverse direction of rotation of the tire. If wear is excessive, true tire. If the source of trouble is the vehicle, diagnose cause and correct as needed.

FIGURE 7-14

DIAGONAL WEAR

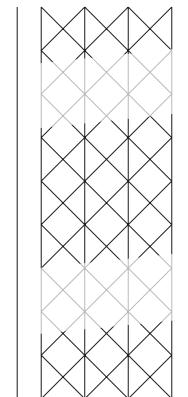
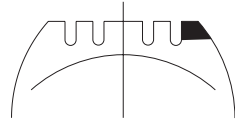




FIGURE 7-15
RAPID SHOULDER WEAR
(One Shoulder Only)



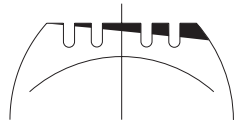
Rapid Shoulder Wear (One Shoulder Only) — Is defined as a tire worn on the edge of one shoulder, sometimes extending to inner ribs. It can progress to diagonal wipe-out. For more information, see TMC RP 219A publication, page 22.

This wear condition is usually caused by excessive toe or excessive camber. These conditions can be created by a misaligned or bent axle and can also be caused by loose or worn wheel bearings.

To correct this type of rapid shoulder wear:

- *Tires* – Change direction of rotation of tire. If shoulder wear is severe, remove and retread.
- *Vehicle* – Diagnose misalignment and/or mechanical condition and correct.

FIGURE 7-16
ONE-SIDED WEAR



One-sided wear — Is excessive wear on one side of tire extending from the shoulder towards the center of the tread. For more information, see TMC RP 219A, page 26.

One-sided wear is usually caused by improper alignment, worn kingpins, loose wheel bearings, excessive camber, excessive axle loads, non-parallel axles, or non-uniform tire and wheel assembly caused by improper bead seating or bent wheel.

To correct one-sided wear:


- *Tires* – Depending on severity, rotate tires to another axle position or, if worn to minimum tread depths, submit for possible retreading.
- *Vehicle* – Diagnose mechanical problem and correct.



AIRTEK®• SOFTEK® for Blue Bird Buses

101

SHOCK ABSORBER INSPECTION

Hendrickson uses a long service life, premium shock absorber on all AIRTEK and SOFTEK suspensions. When the shock absorber replacement is necessary, Hendrickson recommends that the shock absorbers be replaced with identical  Hendrickson Genuine parts for servicing. Failure to do so will affect the suspension performance, durability, and will void the warranty.

Inspection of the shock absorber can be performed by doing a heat test, and a visual inspection. For instructions on shock absorber replacement see the Component Replacement Section of this publication. It is not necessary to replace shock absorbers in pairs if one shock absorber requires replacement.

HEAT TEST

1. Drive the vehicle at moderate speeds on rough road for minimum of fifteen minutes.



WARNING

DO NOT GRAB THE SHOCK AS IT CAN POSSIBLY CAUSE PERSONAL INJURY.

2. Lightly touch the shock body carefully below the dust cover, see Figure 7-17.
3. Touch the frame to get an ambient reference. A warm shock absorber is acceptable, a cold shock absorber should be replaced.
4. To inspect for an internal failure, remove and shake the suspected shock. Listen for the sound of metal parts rattling inside. Rattling of metal parts can indicate that the shock has an internal failure.

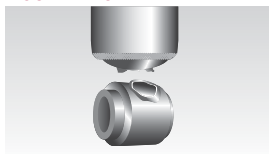
FIGURE 7-17



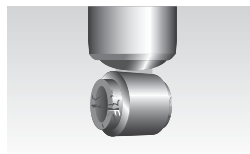
VISUAL INSPECTION

Look for these potential problems when doing a visual inspection. Inspect the shock absorbers fully extended. Replace as necessary.

FIGURE 7-18



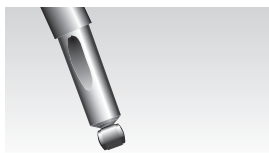
Damaged upper or lower mount



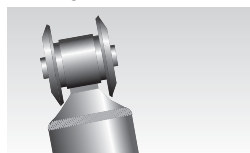
Damaged upper or lower bushing



Damaged dust cover and/or shock body



Bent or dented shock



Improper installation example:
Washers installed backwards
(if equipped)

AIRTEK®• SOFTEK® for Blue Bird Buses



LEAKING VS. MISTING SHOCK VISUAL INSPECTION

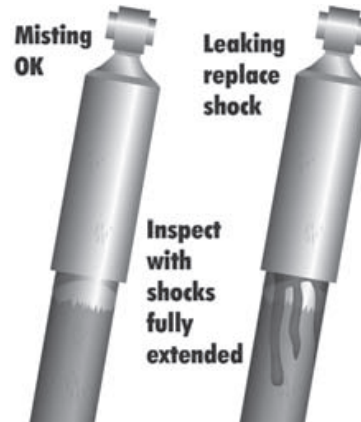
The inspection must not be conducted after driving in wet weather or a vehicle wash. Shocks need to be free from water. Many shocks are often mis-diagnosed as failures. Misting is the process whereby very small amounts of shock fluid evaporate at a high operating temperature through the upper seal of the shock. When the "mist" reaches the cooler outside air, it condenses and forms a film on the outside of the shock body. Misting is perfectly normal and necessary function of the shock. The fluid which evaporates through the seal area helps to lubricate and prolong the life of the seal.

A shock that is truly leaking and needs to be replaced will show signs of fluid leaking in streams from the upper seal. These streams can easily be seen when the shock is fully extended, underneath the main body (dust cover) of the shock. Look for these potential problems when doing a visual inspection. Inspect the shock absorbers fully extended. Replace as necessary.

NOTE

The AIRTEK/SOFTEK suspension is equipped with a premium seal on the shock, however this seal will allow for misting to appear on the shock body (misting is not a leak and is considered acceptable).

FIGURE 7-19



If the shock is damaged install new shock absorber as detailed in the Component Replacement Section of this publication.

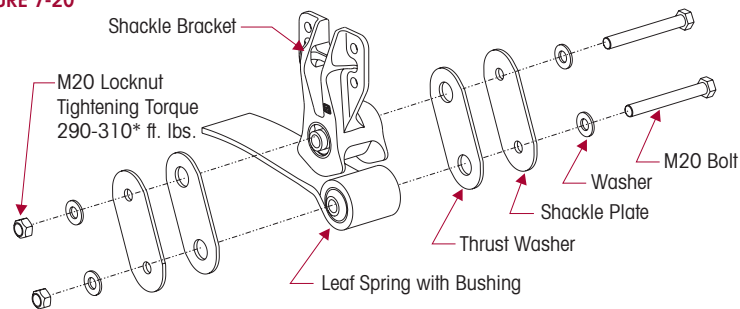
SHACKLE THRUST WASHER INSPECTION (If Equipped)

NOTE

SOFTEK Vision 8K capacity vehicles built after 02/2007, and all other vehicles built after 11/2006 are not equipped with shackle thrust washers.

In normal use these components will function satisfactorily, even though the components may show some wear.

FIGURE 7-20



*Specification provided, controlled and subject to change by vehicle manufacturer.



AIRTEK®•SOFTEK® for Blue Bird Buses

An indication that the shackle thrust washers are worn, or need replacement is when the suspension exhibits one or more of the following conditions:

1. Excessive lateral movement of the spring.
2. The rear spring eye and or thrust washers are in contact with the shackle plates.
3. Normal and unacceptable thickness of the thrust washers (See Figure 7-20) can be measured with a micrometer or a ruler.
 - The normal thickness of a new thrust washer is $\frac{3}{16}$ " (0.187").
 - The minimum thickness allowable for a thrust washer is $\frac{3}{32}$ " (0.090").
 - If one or more of these conditions is experienced, disassembly of the rear shackle assembly is required to replace the thrust washers.
 - If one thrust washer is worn out, Hendrickson recommends both thrust washers on that side of the suspension be replaced. Inspect the thrust washers on the other side of the vehicle and replace if necessary. See Shackle Thrust Washer replacement procedure in the Component Replacement Section of this publication.

AXLE WRAP LINER INSPECTION

INSPECTION PROCEDURE

- Axle wrap liners are installed on the STEERTEK axle to help prevent any type of abrasion on the axle at the clamp group area. Any time an axle wrap is removed it is mandatory that the axle wrap liner be replaced.
- Liner Crack Criteria:

It is possible for the axle wrap liner to crack during service. If the liner is cracked and all the pieces are intact it is not necessary to replace the liner. If the liner is broken out and there are pieces missing the liner must be replaced immediately, see Figure 7-21. See Axle Wrap replacement in the Component Replacement Section of this publication.

FIGURE 7-21

Axle Wrap Liners Unacceptable Cracks





KINGPIN BUSHING INSPECTION

INSPECTION PROCEDURE (STEERING KNUCKLE LATERAL MOVEMENT)

1. Chock the wheels to help prevent the vehicle from moving. Set the parking brake.
2. Use a jack to raise the vehicle until the wheels are off the ground. Support the vehicle with safety stands.

FIGURE 7-22



FIGURE 7-23



3. **CHECKING THE UPPER KINGPIN BUSHING.** Install the base of a dial indicator onto the axle beam and face the tip against the steering knuckle, see Figure 7-22.
4. Set the dial indicator to "0" zero.
5. Move the top of the tire in and out by applying reasonable constant pressure and then release, see Figure 7-24.

FIGURE 7-24



6. Check the reading on the dial indicator. If the dial indicator moves more than 0.015", the upper bushing is worn or damaged. Replace both bushings. Refer to the Kingpin Bushing replacement procedure in the Component Replacement Section of this publication.
7. **CHECKING THE LOWER KINGPIN BUSHING.** Install a dial indicator so that the base is on the axle and the indicator tip is against the inside of the bottom of the knuckle, see Figure 7-23.
8. Set the dial indicator to "0" zero.
9. Move the bottom of the tire in and out. If the dial indicator moves more than 0.015", the lower bushing is worn or damaged. Replace both kingpin bushings. Refer to the Component Replacement Section of this publication.

NOTE

If one bushing is worn or damaged, it is mandatory to replace both the top and bottom bushings on that knuckle assembly.



STEERING KNUCKLE INSPECTION

CHECKING VERTICAL END PLAY (UP AND DOWN MOVEMENT)

The operating spec for vertical clearance on the steering knuckle is 0.008" to 0.030".

1. Chock the rear tires to help prevent the vehicle from moving.
2. Set the parking brakes.
3. Use a jack to raise the vehicle until both tires are 1" off the ground.

FIGURE 7-25

4. Place a dial indicator on each side of the axle as follows:
 - a. Index the wheels slightly (left or right).
 - b. Place the magnetic dial indicator base on the axle, see Figure 7-25.
 - c. Place the tip of the dial indicator on the top of the upper steering knuckle (not on the grease cap).
5. Set the dial indicator to "0" (zero).
6. Lower the jack.
7. If vertical clearance is greater than 0.030", adjust the upper knuckle to obtain clearance specifications, if adjustment does not achieve clearance specification, install shims (Hendrickson part no. 60259-002) between the top of the axle and the bottom of the upper steering knuckle to obtain the proper clearance specification. See Steering Knuckle Assembly in the Component Replacement Section of this publication for proper shim installation.
8. If vertical clearance is below 0.008", adjust the upper steering knuckle to obtain the proper clearance specification, if adjustment does not achieve clearance specification, remove shims. See Steering Knuckle Assembly in the Component Replacement Section of this publication for proper shim removal.





SECTION 8 Alignment & Adjustments

106

ALIGNMENT DEFINITIONS

Ackermann Steering Geometry — The geometry of the four bar linkage consisting of the front axle beam pivot points, tie rod arms, and cross tube and attempts to provide free rolling of front tires in a turn. Ackermann geometry is dependent upon the steering axle track-width and wheelbase of the vehicle. Improper geometry results in wheel scrub in turns which generally appears as toe wear on the tire. Usually more wear is present on one side of the vehicle than the other due to the operational route of the vehicle.

Bump Steer (Feedback) — The feedback felt through the steering linkage to the steering wheel when a steer axle tire hits a bump in the road. This occurs because the axle-end of the drag link and the axle attachment point of the spring do not travel in parallel circular arcs as the suspension moves up and down. This condition can also be caused by trapped air in the power steering system.

FIGURE 8-1

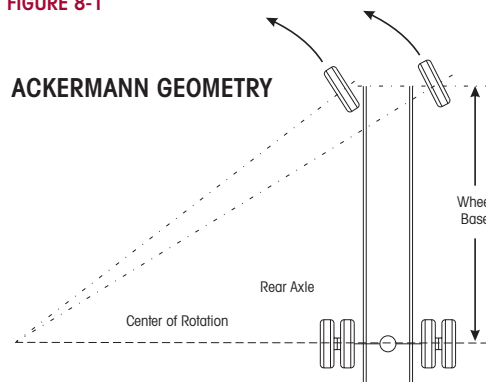
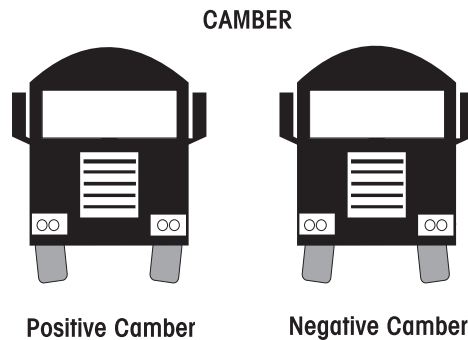


FIGURE 8-2

Camber — The angle formed by the inward or outward tilt of the wheel reference to a vertical line. Camber is positive when the wheel is tilted outward at the top and is negative when the wheel is tilted inward at the top.

Excessive positive camber may cause smooth wear on the outer half of the tire tread. Excessive negative camber may cause wear on the inner half of the tread. Static-unloaded camber angles are built into the axle to put the loaded tire perpendicular to the road.





AIRTEK®• SOFTEK® for Blue Bird Buses

107

Caster — The forward or rearward tilt of the steering axle kingpin in reference to a vertical line. The angle is measured in degrees. Caster is positive when the top of the steering axis is tilted rearward and is negative when the tilt is forward. Proper caster is important for directional stability and returnability. Too much positive caster can cause shimmy, excessive steering effort and is normally a vehicle performance and handling consideration. Uneven positive caster may create a steering pull toward the side with the lower caster. This attribute may be used to compensate for crowned roads.

FIGURE 8-3

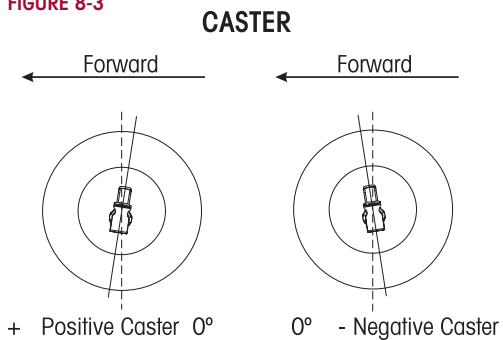
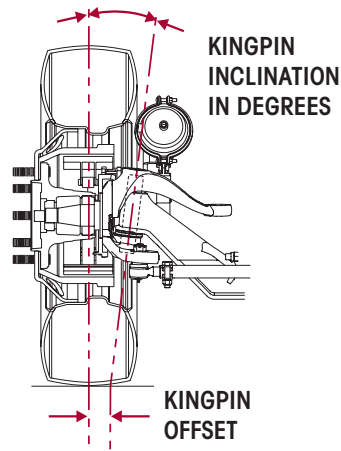


FIGURE 8-4



Kingpin Inclination (KPI) — The inward tilt of the kingpin from the vertical. This front suspension parameter has a pronounced effect on steering effort and returnability. As the front wheels are turned around an inclined kingpin, the front of the truck is lifted. This lifting of the vehicle is experienced as steering effort when the turn is executed and exhibits itself as recovery force when the steering wheel is released.

Kingpin Offset — The distance between the center of the tire patch and intersection of the kingpin axis with the ground. This parameter of front end geometry is important in vehicles without power steering and has a major effect on static steering. If there is no kingpin offset, the tires must scrub around the center of the pin patch when turned in a static condition, resulting in higher static steering efforts.

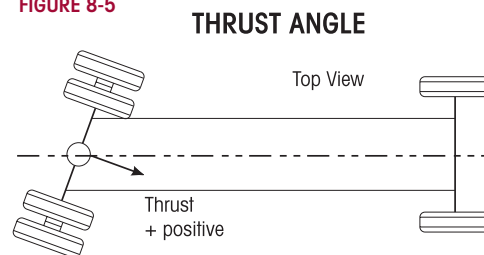
Steering Arm — The component that connects the drag link to the axle knuckle assembly.

Thrust Angle, Tracking, or Square

— The angle formed by the centerline of the vehicle frame (geometric centerline) and the direction that an axle points. As indicated by the term "square", the ideal value for the angle is 0° or when the axle centerline is at 90° or perpendicular to the geometric centerline. Thrust or tracking to the right is positive, and to the left is negative.

A steering correction is required to offset the effect of the thrust angles and keeps the vehicle traveling in a straight line. It results in a lateral offset between the steer and drive axle tires commonly referred to as "dog tracking."

FIGURE 8-5

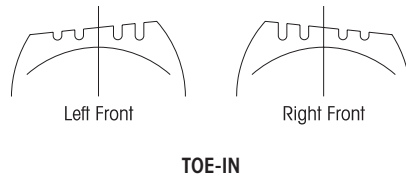


AIRTEK® • SOFTEK® for Blue Bird Buses



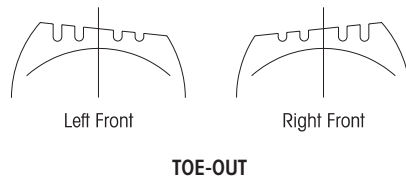
Tie Rod Arm (Ackermann-Arm, Cross Tube Arm) — The component that transmits steering forces between left and right axle knuckle assemblies through the cross tube assembly.

FIGURE 8-6



Toe-in — is when the horizontal line intersects in front of the wheels, or the wheels are closer together in front than in the back. Toe-in is commonly designated as positive, toe-out as negative. Excessive toe-in wears the outside edge of the tires. Steer axle toe is adjustable to reduce wear to the leading edge of the tire and also to avoid road wander. Toe is adjusted in a static, unloaded condition so that the tires will run in a straight line under a dynamic, loaded condition.

FIGURE 8-7

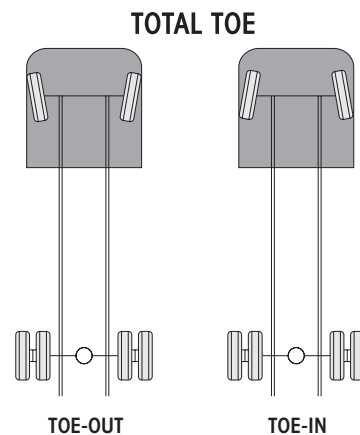


Toe-out — Is when the horizontal lines intersect behind the wheels, or the wheels are closer together in back than in front. Toe-in is commonly designated as positive, toe-out as negative. Excessive toe-out wears the inside edge of the tires. Steer axle toe is adjustable to reduce wear to the leading edge of the tire and also to avoid road wander. Toe is adjusted in a static, unloaded condition so that the tires will run in a straight line under a dynamic, loaded condition.

Toe-Out on Turns — (See Ackermann Geometry). Excessive turning angles such as those encountered in pickup and delivery operations may contribute to premature tire wear. Be advised that the greater the turning angles, the more that toe and camber change. If you have any doubt regarding the optimum turning angles for your operation, contact the vehicle's manufacturer, axle OEM, tire OEM and alignment equipment manufacturer for advice.

Total Toe — The angle formed by two horizontal lines through the planes of two wheels. Steer axle toe is adjustable to reduce wear to the leading edge of the tire and also to avoid road wander. Toe is adjusted in a static, unloaded condition so that the tires will run in a straight line under a dynamic, loaded condition.

FIGURE 8-8





INSPECTION PRIOR TO ALIGNMENT


WHEELS AND TIRES

Examine the following items:

- The tires are inflated to the manufacturer's specified tire pressure.
- The steer axle tires are the same size and type.
- The lug nuts are tightened to manufacturer's specified torque.
- The wheels are balanced and check for tire to rim runout.
- The wheels and tires are free of excessive wear and damage.
- Wheel bearing end play is within OEM specification.

FRONT SUSPENSION

Inspect the following:

- All fasteners are installed and tightened to the specified torque. See  Tightening Torque Specification Section in the appendix of this publication.
- Leaf springs are free of wear or damage.
- Air springs are free of wear or damage (if equipped).
- Shock absorbers are free of wear and damage.
- Vehicle ride height for both the front and rear are within specification. Follow manufacturers guidelines (if equipped).
- Front and rear spring mounts for wear or damage.

INSPECT TIE ROD ENDS

Perform "Tie Rod Inspection" procedure, refer to the Preventive Maintenance Section of this publication.

REAR AXLE AND REAR SUSPENSION

Rear axle misalignment can cause front tire wear. If the outer edge of one front tire is worn and the inner edge of the other front tire is worn, check the following:

- Make sure the rear axle (especially a tandem axle) is correctly aligned. Refer to the procedure from the manufacturer of the vehicle or the suspension.
- All fasteners including U-bolts (if applicable) are installed and tightened to the specified torque.
- The leaf springs are not worn or damaged.
- The bushings in the leaf springs are not worn or damaged.
- The torque rods (if used) are correctly adjusted (if adjustable).
- The frame is not bent or twisted.
- Refer to any additional recommendations and specifications from the manufacturer of vehicle on rear axles and suspensions. Reference the TMC (The Technology & Maintenance Council) Guidelines for Total Vehicle Alignment.



FRONT WHEEL ALIGNMENT

Hendrickson recommends technicians review TMC’s publication TMC (Technology & Maintenance Council) “Guidelines for Total Vehicle Alignment”.

The AIRTEK/SOFTEK front wheel alignment specification can be found in the Appendix of this publication.

Check the total vehicle wheel alignment when the following occur:

- Every 80,000 to 100,000 miles, or 12-18 months (normal maintenance).
- When the vehicle does not steer correctly.
- To correct a tire wear condition.
- There are two types of front wheel alignment:
 1. *Minor alignment* – a minor front wheel alignment is done **for all** normal maintenance conditions, see below.
 2. *Major alignment* – a major alignment is done when uneven or excessive tire wear is evident, or response at the steering wheel is sluggish, or the need for major wheel alignment check and adjustment is required, see below.

MINOR FRONT WHEEL ALIGNMENT

Perform the minor front wheel alignment in the following sequence:

1. Inspect all systems that affect wheel alignment. Refer to “Inspection Prior to Alignment” in this Section.
2. Check the wheel bearing end play.
3. Check and adjust the vehicle ride height (for AIRTEK) as specified in the Preventive Maintenance Section of this publication.
4. Check toe-in and adjust if necessary.

MAJOR FRONT WHEEL ALIGNMENT

Be certain to follow wheel alignment inspection intervals as specified by the original equipment manufacturer. Before performing a major front wheel alignment it is recommended that alignment equipment calibration be checked to ensure proper vehicle alignment.

Major wheel alignment is accomplished in the following sequence of operation:

1. Inspect all the systems that influence the wheel alignment. Refer to the “Inspection Prior to Alignment” in this section.
2. Check and adjust the maximum turn angle, (see “Steering Stop Procedure” in this section). See Figures 8-9 and 8-10.
3. If the vehicle has power steering, check and adjust, if necessary, the pressure relief in the power steering system. Refer to vehicle manufacturer’s specifications See Steer Stops in the Alignment & Adjustments Section of this publication.
4. Verify the turning angle per step 2, (toe-out during vehicle turns or the Ackermann angle). Refer to vehicle manufacturer’s specifications.





AIRTEK®• SOFTEK® for Blue Bird Buses

FIGURE 8-9



FIGURE 8-10



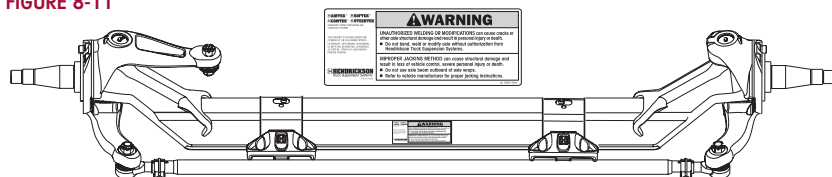
111

5. Check the kingpin (or steering axis) inclination (the kingpin inclination is not adjustable). Refer to "Kingpin Inclination", in the Definitions under the Alignment & Adjustments Section of this publication.
6. Check the camber angle. Do not attempt to adjust. Refer to "Camber" in the Definitions under the Alignment & Adjustments Section of this publication.

WARNING

AXLE CAMBER IS NOT ADJUSTABLE. DO NOT CHANGE THE AXLE CAMBER ANGLE OR BEND THE AXLE BEAM. BENDING THE AXLE BEAM TO CHANGE THE CAMBER ANGLE CAN DAMAGE THE AXLE AND REDUCE AXLE STRENGTH, AND WILL VOID HENDRICKSON'S WARRANTY. A BENT AXLE BEAM CAN CAUSE LOSS OF VEHICLE CONTROL, POSSIBLY CAUSING PERSONAL INJURY OR PROPERTY DAMAGE, SEE FIGURE 8-11.

FIGURE 8-11



7. Check and adjust caster angle. Refer to "Caster" in the Definitions under the Alignment & Adjustments Section of this publication. **The use of two different angle caster shims will not change cross caster.** Cross caster is the difference between the caster readings for left and right side of the vehicle.

SERVICE HINT

Prior to checking caster confirm that the vehicle is at its proper ride height front and rear. The front and rear ride height must be correct to achieve proper caster.

8. Check and adjust toe-in, refer to adjusting the Toe-In under "Definitions" in the Alignment & Adjustments Section of this publication.



AIRTEK RIDE HEIGHT ADJUSTMENT

1. Drive the vehicle onto a level surface.
2. Free and center all suspension joints by slowly moving vehicle back and forth several times without using the brakes. **It is important when coming to a complete stop to verify that the brakes are released.**
3. Chock front wheels.

NOTE

Hendrickson recommends the following be performed during any type of ride height adjustment to help prevent socket head cap screws from loosening from the height control valve housing, and any subsequent air leaks from the height control valve.

4. Prior to adjusting the height control valve, clean the threads of the 1/4" valve mounting fasteners to remove any debris and corrosion.

WARNING

PRIOR TO AND DURING DEFLATION AND INFLATION OF THE FRONT AIR SUSPENSION SYSTEM, ENSURE THAT ALL PERSONNEL AND EQUIPMENT ARE CLEAR FROM UNDER THE VEHICLE AND AROUND THE SERVICE AREA, FAILURE TO DO SO CAN CAUSE SERIOUS PERSONAL INJURY, DEATH, OR PROPERTY DAMAGE.

5. Detach the upper rubber grommet of the height control valve linkage from the upper stud and exhaust the suspension system air by lowering the height control valve linkage arm.
6. Re-attach the upper grommet of the height control valve linkage onto the upper stud to fill the suspension system with air. Wait until the airflow to front air springs has stopped.
7. Measure the suspension reference ride height on the shock absorber, see Figure 8-12 and 8-13, measuring from the center of the top mounting bolt to the center of the bottom mounting bolt.
8. The different referenced ride height measurements are as specified in following chart. If the reference measurement is not within $\pm 1/4"$ of the specification, the ride height **MUST** be adjusted.

FIGURE 8-12 - 10K

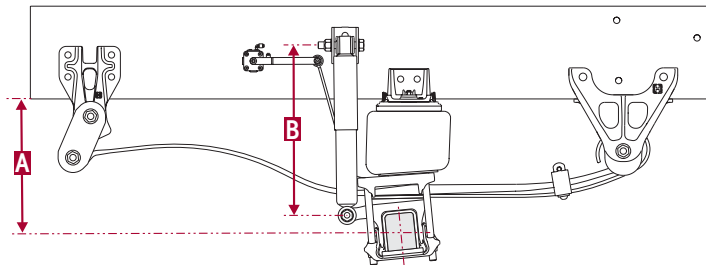
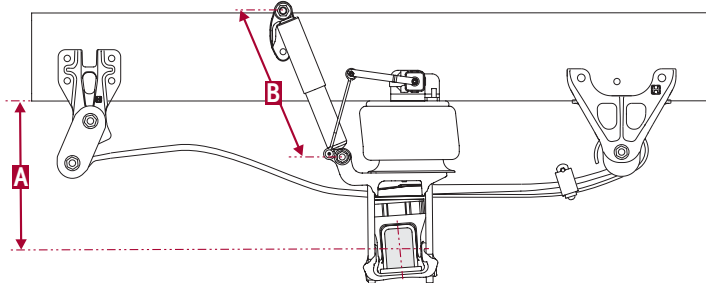


FIGURE 8-13 - 14.6K





AIRTEK® • SOFTEK® for Blue Bird Buses

Blue Bird Model	AIRTEK (FRONT)		COMFORT AIR (REAR)	
	RIDE HEIGHT	SHOCK ABSORBER LENGTH	RIDE HEIGHT	SHOCK ABSORBER LENGTH
	A	B		
	From the bottom of the frame to the center of axle	At ride height with a tolerance of 1/4"	From the bottom of the frame to the bottom of the main support member.	At ride height with a tolerance of 1/4"
Vision 10K	12 1/2"	18 5/16"	4 7/8"	22 3/4"
All American Front Engine	14 7/8"	17 1/4"		
All American Rear Engine	14 7/8"	17 1 5/32"		

9. Detach the upper grommet of the height control valve linkage from the stud on the leveling valve arm and exhaust suspension system air.
10. Adjust the height control valve by loosening the 1/4" mounting locknuts and pivoting the valve body about the mounting bolt.

NOTE

It is necessary to place a 3/16" allen wrench in the head of the mounting bolts while adjusting ride height to prevent movement of the bolts, which can cause air leakage in the body of the leveling valve.

11. Facing the air spring from the outboard side of the vehicle, pivot the valve body clockwise to increase the ride height and counter clockwise to decrease the ride height.
12. Tighten the 1/4" mounting locknuts to 8-10 foot pounds, (see Figure 8-14 and 8-15) and repeat steps 4 through 10 until the reference measurement equals ± 1/4" of the specification. See Figure 8-12 and 8-13.

SERVICE HINT

It is very important that the leveling valve be cycled completely before and after any ride height adjustments. This cycling of the leveling valve will help to make the adjustment as accurate as possible.

FIGURE 8-14

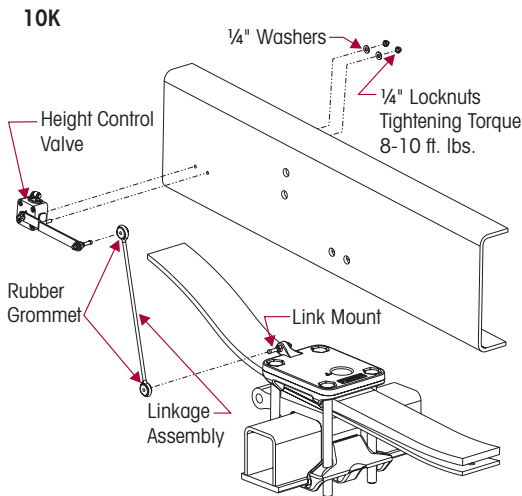
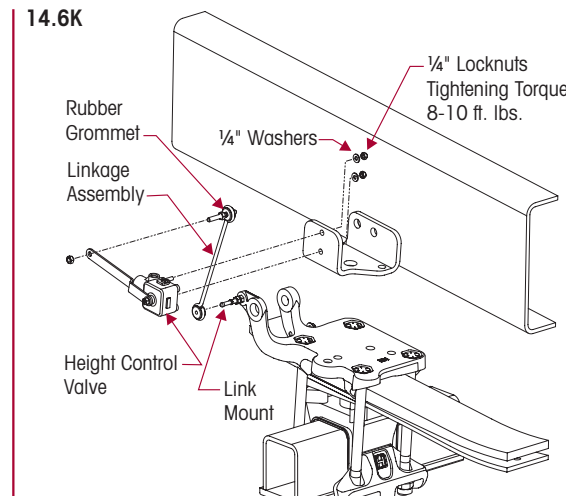


FIGURE 8-15





AIRTEK HEIGHT CONTROL VALVE TEST

The height control valve test can be done with Barksdale Test Kit (Model 55521).

KIT CONTENTS

QTY.	DESCRIPTION	QTY.	DESCRIPTION	QTY.	DESCRIPTION
1	Gauge	1	Valve	2	Plug
1	(F3) Fitting	1	(T1) Tubing ¼"	1	Fitting
1	Flush Plug	1	Tool	1	O-Ring

HEIGHT CONTROL VALVE TEST INSTRUCTIONS

1. Disconnect linkage from valve handle.
2. Lower height control valve linkage arm down to exhaust air from the suspension system.
3. Remove the tubing from both air spring ports, see Figure 8-16. Place supplied tool around the tubing, press down to pull out tubing. **DO NOT CUT THE TUBING.**
4. Install the red plugs supplied into the air spring ports.
5. Use needle nose pliers to remove the "flapper" from the valve exhaust port.
6. Install hex fitting F3 (the one with a small pin protruding) into the exhaust port. To install hex fitting into exhaust port align pin on fitting with slot on exhaust port, push in and rotate clockwise to stop.
7. Connect one end of the tubing (T1) to this port and one end into the test gauge valve.
8. Rotate the test gauge valve handle to test mode, see diagram in Figure 8-16.
9. Rotate handle on valve being tested to fill mode.
10. Observe pressure reading for a period of 30 seconds.
11. Refer to chart for maximum allowable pressure drop vs.inlet pressure in. 30 seconds, see Figure 8-17. The valve is good if the pressure drop does not exceed the maximum allowable.
12. Rotate vehicle valve handle to exhaust mode.
13. Rotate test gauge valve handle to test mode. Repeat steps 10, 11.
14. Replace valve if maximum allowable drop is exceeded.

FIGURE 8-16

DIAGRAM

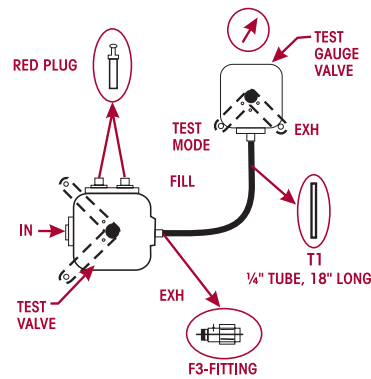
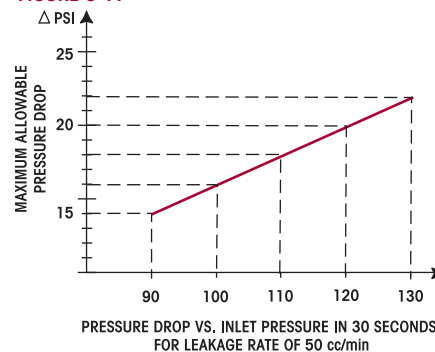


FIGURE 8-17



This test is complete. Remove test gauge valve and fitting from the exhaust port. Remove the red plugs from the air spring ports. Reconnect the air spring tubing to the valve, ensuring that the air lines are pushed fully into the PTC fittings. Reconnect the linkage to the valve handle. Suspension ride height will automatically return to the correct position.





AIRTEK®• SOFTEK® for Blue Bird Buses

115

STEERING STOP

ADJUSTMENT PROCEDURE

When the axle or lower steering knuckle is replaced, the steering stop adjustment must be checked.

The steering stop adjustment procedure is as follows:

1. Drive truck onto turntables and chock the rear wheels.
2. Measure the wheel cut. The wheel cut is determined by steering the tires. Wheel cut is measured at the inside wheel only, therefore the tires must be turned to the full lock position for each right hand and left hand direction. Refer to the vehicle manufacturer for exact specifications.
3. Increase the wheel cut by loosening the jam nuts and screw the axle stops in clockwise.
4. Tighten the jam nuts.

FIGURE 8-18



NOTE

It is very important that the sides of the square head axle stops are set parallel to the axle beam to ensure a good contact point on the axle, see Figure 8-18.

5. Decrease the wheel cut by loosening the jam nuts and screw the axle stops out counter-clockwise.
6. Tighten the jam nuts to 40-60 foot pounds torque.
7. Measure the wheel cut and check for any interference with related steering components.

WARNING

ALWAYS CHECK/RESET THE STEERING GEAR BOX POPPET WHEN THE WHEEL CUT IS DECREASED. FOLLOW MANUFACTURER'S GUIDELINES FOR THE GEAR BOX POPPET RESETTING PROCEDURE. FAILURE TO DO SO CAN RESULT IN PREMATURE FAILURE OF THE AXLE OR STEERING KNUCKLE. THIS CONDITION CAN CAUSE LOSS OF VEHICLE CONTROL, PERSONAL INJURY OR PROPERTY DAMAGE AND VOID WARRANTY.



TOE SETTING

1. Place the vehicle on a level floor with the wheels in a straight ahead position.
2. Raise the vehicle and support the front axle with jack stands.
3. Use paint and mark the center area of tread on both steer axle tires around the complete outer diameter of the tires.
4. Scribe a line through both steer axle tires in the painted area around the complete outer diameter of the tires.
5. Raise the vehicle and remove the jack stands.
6. Set the vehicle on the ground.

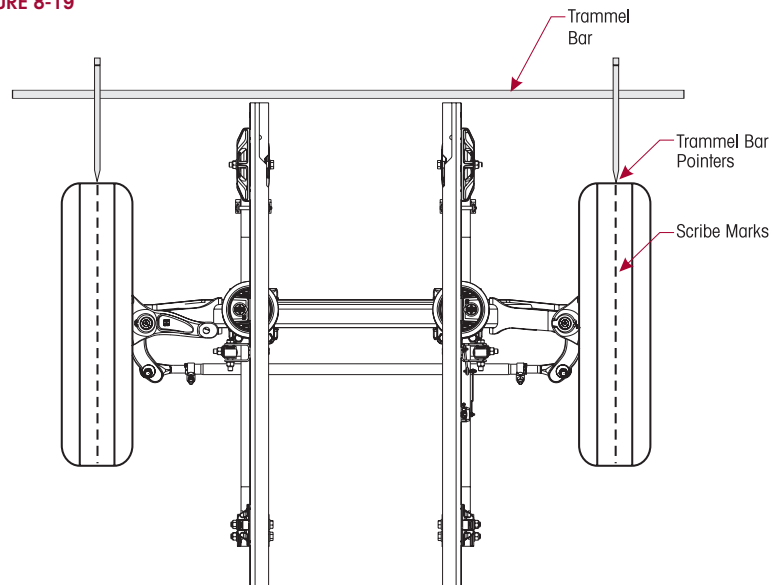
NOTE Do not measure toe-in with the front axle off the ground. The weight of the vehicle must be on the front axle when toe-in is measured.

7. Use a trammel bar and measure the distance between the scribe marks at the rear of the steer axle tires. Record the measurement.
8. Install the trammel bar and measure the distance between the scribe marks at the front of the steer axle tires. Record the measurement, see Figure 8-19.

NOTE When setting up the trammel bar the pointers should be level with the spindles at the front and rear of the steer axle tires.

9. To calculate the toe setting subtract the front measurement from the rear measurement, the difference between the two will equal the toe-in/toe-out measurement.

FIGURE 8-19





AIRTEK®• SOFTEK® for Blue Bird Buses

10. If the toe measurement is not within the specifications of $\frac{1}{16}'' \pm \frac{1}{32}''$ ($0.060'' \pm 0.030''$), it will be necessary to adjust the toe setting. Refer to the following procedure.

- a. Loosen the tie rod cross tube clamp bolts and locknuts.
- b. Turn the tie rod cross tube until the specified toe-in distance is achieved.

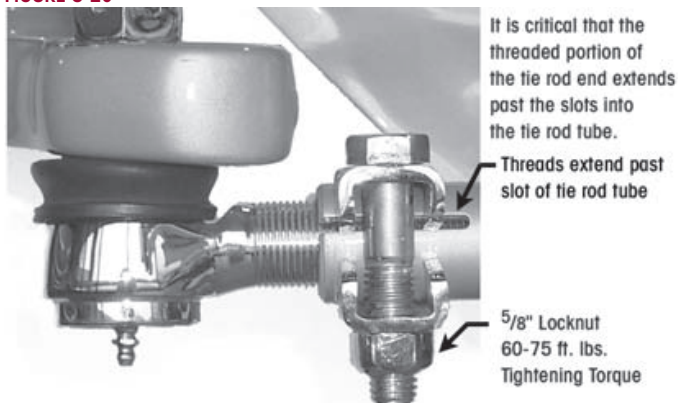
WARNING

THE THREADED PORTION OF THE TIE ROD END MUST EXTEND PAST THE SLOTS INTO THE TIE ROD CROSS TUBE, SEE FIGURE 8-20. FAILURE TO DO SO CAN CAUSE COMPONENT TO FAIL CAUSING LOSS OF VEHICLE CONTROL AND POSSIBLE PERSONAL INJURY OR PROPERTY DAMAGE.

- c. Tighten the bolt and locknut on the tie rod cross tube to 60-75 foot pounds torque.

11. Repeat steps 1-9 until the correct toe setting is achieved.

FIGURE 8-20





SPRING EYE RE-TORQUE

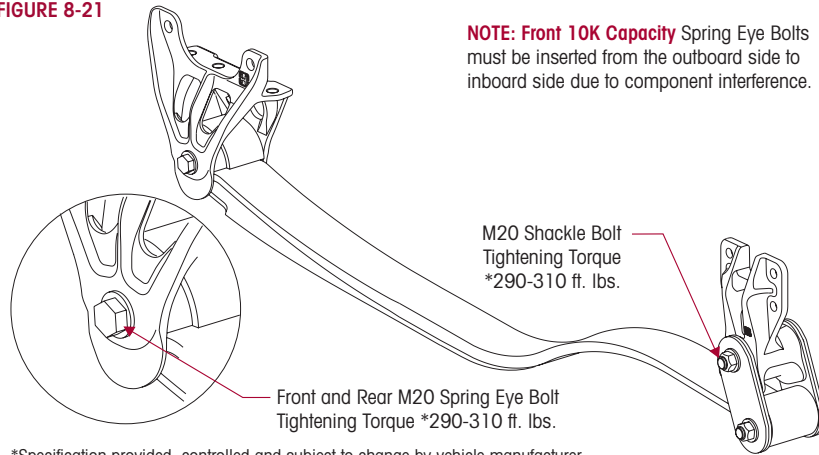
This procedure to re-torque is necessary when replacing

- Front Hanger
- Shackle Assembly
- Steel Leaf Spring Assembly

AIRTEK RE-TORQUE PROCEDURE

1. Chock the rear wheels of the vehicle to prevent movement.
2. Verify ride height. Adjust if necessary, see AIRTEK Ride Height adjustment procedure in this section.
3. Loosen all six (6) front and rear spring eye bolts, see Figure 8-21.

FIGURE 8-21



NOTE: Front 10K Capacity Spring Eye Bolts must be inserted from the outboard side to inboard side due to component interference.

M20 Shackle Bolt
Tightening Torque
*290-310 ft. lbs.

Front and Rear M20 Spring Eye Bolt
Tightening Torque *290-310 ft. lbs.

*Specification provided, controlled and subject to change by vehicle manufacturer.

FIGURE 8-22



NOTE

DO NOT remove the spring eye bolts.

4. Let the suspension settle.
5. Tighten the front M20 spring eye bolt locknuts to vehicle manufacturer's specifications.
6. Tighten the rear M20 spring eye bolt and shackle bolt locknuts to vehicle manufacturer's specifications.
7. Affix a straight edge to the bottom of the frame rail in front of the air spring, see Figure 8-22.
8. With the vehicle on a level surface measure the distance from the top of the straight edge to the ground on both sides of the vehicle and record the measurements.
9. Measure the difference from one side to the other.



AIRTEK®• SOFTEK® for Blue Bird Buses

10. Do a road test and repeat measurement steps 7 to 9.
11. If the measurement is less than $\frac{3}{8}$ " the vehicle is level. If measurement is more than $\frac{3}{8}$ " contact Hendrickson Tech Services.

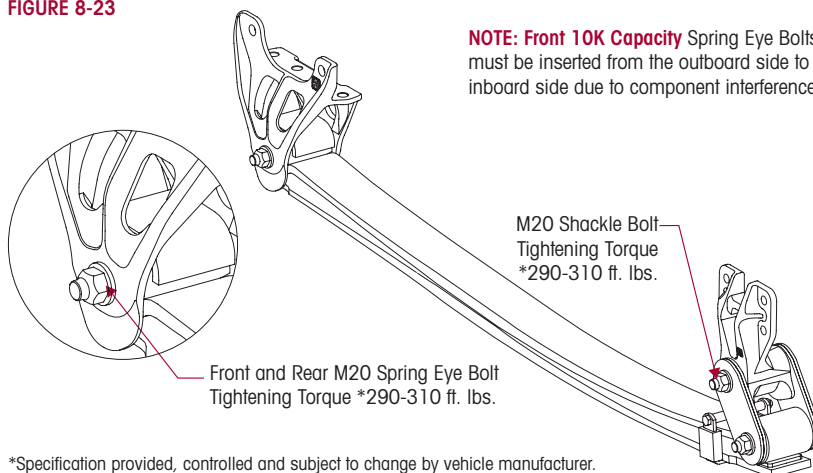
SOFTEK RE-TORQUE PROCEDURE

1. Chock the wheels.
2. Loosen all six (6) front and rear spring eye bolts, see Figure 8-23.

NOTE

Do not remove the spring eye bolts.

FIGURE 8-23



NOTE: Front 10K Capacity Spring Eye Bolts must be inserted from the outboard side to inboard side due to component interference.

*Specification provided, controlled and subject to change by vehicle manufacturer.

3. Let the suspension settle.
4. Tighten the front M20 spring eye bolt locknuts to vehicle manufacturer's specifications.
5. Tighten the rear M20 spring eye bolt and shackle bolt locknuts to vehicle manufacturer's specifications.
6. Affix a straight edge to the bottom of the frame rail behind frame hanger, see Figure 8-22.
7. With the vehicle on a level surface measure the distance from the top of the straight edge to the ground on both sides of the vehicle and record the measurements.
8. Measure the difference from one side to the other.
9. Do a road test and repeat measurement steps 7 to 9.
10. If the measurement is less than $\frac{3}{8}$ " the vehicle is level. If measurement is more than $\frac{3}{8}$ " contact Hendrickson Tech Services.



SECTION 9 Component Replacement

120

FASTENERS

Hendrickson recommends that when servicing the vehicle to replace the removed fasteners with new equivalent fasteners. Maintain correct torque values at all times. Check torque values as specified. See Hendrickson's Torque Specifications in the Appendix of this publication. If non-Hendrickson fasteners are used follow torque specifications listed in the vehicle manufacturer's service manual.

SPACERS

There are different front axle spacer configurations for each front suspension system. Prior to disassembly of the front axle clamp group, note the orientation and quantity of the front axle spacer(s) (if equipped). It is required that the axle spacers be installed in the same orientation and location as removed to preserve the existing vertical alignment. Refer to the Parts List section in this publication.

AIRTEK HEIGHT CONTROL VALVE – 10K

DISASSEMBLY

1. Drain the air from the secondary air tank.

WARNING

PRIOR TO AND DURING DEFLATION AND INFLATION OF THE FRONT AIR SUSPENSION SYSTEM, ENSURE THAT ALL PERSONNEL AND EQUIPMENT ARE CLEAR FROM UNDER THE VEHICLE AND AROUND THE SERVICE AREA, FAILURE TO DO SO CAN CAUSE SERIOUS PERSONAL INJURY, DEATH, OR PROPERTY DAMAGE.

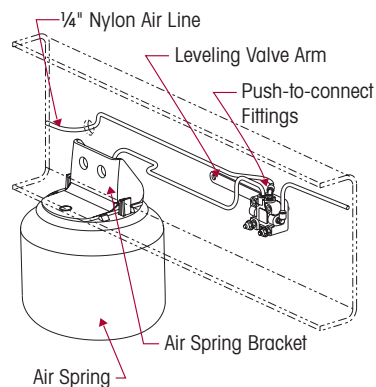
2. Deflate the air springs by removing the height control valve linkage at the rubber grommet and lowering the height control linkage arm. This will exhaust the air pressure in the air springs.

CAUTION

THE PUSH-TO-CONNECT FITTINGS ARE NON-SERVICEABLE. IT IS NECESSARY TO CLEAN THE DIRT AND DEBRIS AWAY FROM THE PUSH-TO-CONNECT FITTINGS AND THE AIR LINES TO HELP PREVENT ANY FOREIGN MATERIAL FROM ENTERING THE AIR SPRING, AIR SYSTEM OR DAMAGING THE PUSH-TO-CONNECT FITTINGS. CLEAN PUSH-TO-CONNECT FITTINGS USING SOAPY WATER AND A SOFT BRISTLED BRUSH AND DRY WITH COMPRESSED AIR.

3. Remove the the air lines from the height control valve. See Figure 9-1. The air lines are push-to-connect. Push in on the air line to release tension, push down on the collar and pull out the air line.
4. Remove the two 1/4" mounting nuts and washers.
5. Remove the height control valve.

FIGURE 9-1 10K

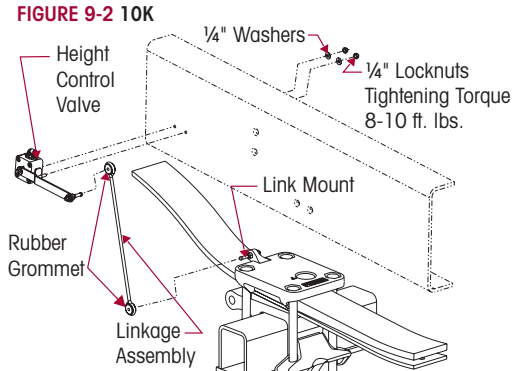




AIRTEK®• SOFTEK® for Blue Bird Buses

ASSEMBLY

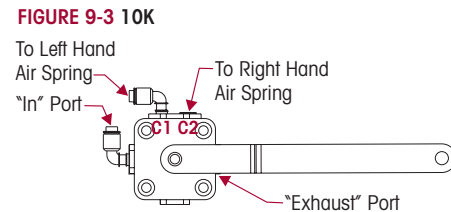
1. Attach the height control valve on the vehicle frame as shown in Figure 9-1.
2. Attach the ¼" washers and the locknuts. Do not tighten the locknuts to specified torque until after the proper ride height is attained. Mount the height control valve parallel to flange of the frame. See Figure 9-2.



SERVICE HINT

When replacing or installing nylon air line tubing into quick-connect fittings, it is critical that the end of the air line is cut square. Improper cut of the end of the air line tubing can cause the air line to seat improperly in the quick connect fitting causing air leakage.

3. Attach the air lines to the height control valve, see Figure 9-3.
4. Install the height control valve linkage assembly.
5. Adjust the height control valve to proper specifications. See the Alignment & Adjustments Section in this publication for proper ride height adjustment.
6. Tighten the ¼" locknuts to 8-10 foot pounds torque.



AIRTEK HEIGHT CONTROL VALVE – 14.6K

DISASSEMBLY

1. Drain the air from the secondary air tank.

WARNING

PRIOR TO AND DURING DEFLATION AND INFLATION OF THE FRONT AIR SUSPENSION SYSTEM, ENSURE THAT ALL PERSONNEL AND EQUIPMENT ARE CLEAR FROM UNDER THE VEHICLE AND AROUND THE SERVICE AREA, FAILURE TO DO SO CAN CAUSE SERIOUS PERSONAL INJURY, DEATH, OR PROPERTY DAMAGE.

2. Deflate the air springs by removing the height control valve linkage at the rubber grommet and lowering the height control linkage arm. This will exhaust the air pressure in the air springs.

CAUTION

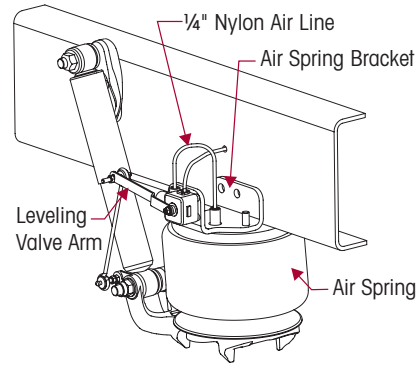
THE PUSH-TO-CONNECT FITTINGS ARE NON-SERVICEABLE. IT IS NECESSARY TO CLEAN THE DIRT AND DEBRIS AWAY FROM THE PUSH-TO-CONNECT FITTINGS AND THE AIR LINES TO HELP PREVENT ANY FOREIGN MATERIAL FROM ENTERING THE AIR SPRING, AIR SYSTEM OR DAMAGING THE PUSH-TO-CONNECT FITTINGS. CLEAN PUSH-TO-CONNECT FITTINGS USING SOAPY WATER AND A SOFT BRISTLED BRUSH AND DRY WITH COMPRESSED AIR.

AIRTEK®• SOFTEK® for Blue Bird Buses



3. Remove the the air lines from the height control valve. See Figure 9-4. The air lines are push-to-connect. Push in on the air line to release tension, push down on the collar and pull out the air line.
4. Remove the two ¼" mounting nuts and washers.
5. Remove the height control valve.

FIGURE 9-4 14.6K

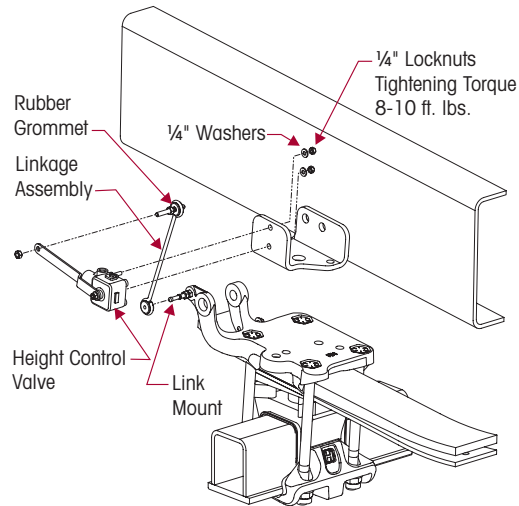


ASSEMBLY

1. Re-install the air fittings into the height control valve. Ensure the Teflon® thread sealing ring is seated around the base of the fitting's hex shoulder. Torque to 3-15 foot pounds (4-20 Nm).
2. Install the height control valve to the upper air spring bracket by attaching the ¼" washers and locknuts. Torque to 8-10 foot pounds. See Figure 9-5.

FIGURE 9-5 14.6K

3. Install the air lines to the height control valve. Reference the Plumbing Diagram Section of this publication.
4. Inflate the suspension by connecting the height control valve linkage to the height control valve arm and lower mounting bracket. Verify the air springs inflate uniformly without binding.
5. Remove the frame supports.
6. Remove the wheel chocks.
7. Verify proper ride height adjustment, (see ride height adjustment in the Alignment & Adjustments Section of this publication).



**AIRTEK®• SOFTEK® for Blue Bird Buses****123****AIRTEK AIR SPRING – 10K****DISASSEMBLY**

1. Place the vehicle on level floor.
2. Chock the wheels.
3. Raise the frame.
4. Support the vehicle with frame stands.

 **WARNING**

WHEN SERVICING THE VEHICLE OR ATTACHING AN AIR SPRING AND THE VEHICLE IS ON THE GROUND, PRIOR TO AIRING THE SUSPENSION SYSTEM MAKE CERTAIN THE AIR SPRING LOCATOR IS INDEXED INTO THE UPPER AIR SPRING BRACKET PROPERLY, AND THE AIR SPRING IS FULLY SEATED ON THE SPRING TOP PAD. FAILURE TO FOLLOW THESE INSTRUCTIONS CAN RESULT IN PREMATURE AIR SPRING FAILURE, CAUSE PERSONAL INJURY, OR PROPERTY DAMAGE.

 **WARNING**

PRIOR TO AND DURING DEFLATION AND INFLATION OF THE FRONT AIR SUSPENSION SYSTEM, ENSURE THAT ALL PERSONNEL AND EQUIPMENT ARE CLEAR FROM UNDER THE VEHICLE AND AROUND THE SERVICE AREA, FAILURE TO DO SO CAN CAUSE SERIOUS PERSONAL INJURY, DEATH, OR PROPERTY DAMAGE.

5. See Air Spring Cautions and Warnings in the Important Safety Notice Section of this publication prior to inflating or deflating the suspension system.
6. Remove the air from the air system by disconnecting the height control valve linkage at the rubber grommet of the height control valve arm and allow the arm to drop. This will exhaust air from the system.

 **WARNING**

IF THE AIR SPRING IS TO BE RE-INSTALLED; INSPECT LOCK-TABS FOR DAMAGE OR CRACKS PRIOR TO RE-INSTALLATION. CARE MUST BE TAKEN TO REMOVE DIRT AND DEBRIS FROM THE PUSH-TO-CONNECT FITTING. FAILURE TO DO SO CAN RESULT IN THE PUSH-TO-CONNECT FITTING FAILING TO SEAL WITH THE AIR LINE.

7. Disconnect the air line to the air spring.
8. Raise the frame to allow for air spring removal.
9. Separate the air spring from the upper air spring bracket by applying downward pressure on air spring, see Figure 9-6, pushing outward on the lock-tabs outside the bracket, and inward on inlet lock-tabs. This will dislodge the air spring from the upper air spring bracket.
10. Apply upward pressure between the base of the air spring and the top pad. This will dislodge the air spring from the top pad. See Figure 9-7.
11. Remove the air spring.



FIGURE 9-6



FIGURE 9-7



ASSEMBLY

1. Insert the air spring into the top pad. Make sure the lock tabs click in place.
2. Compress the air spring and slide into vertical position. There is a locating nodule on the air spring to index the position in the upper air spring bracket.
3. Pull the air spring up into the upper air spring bracket until the air spring snaps into place in the upper air spring bracket. Verify all four lock-tabs are engaged. See Figure 9-8.

FIGURE 9-8

Top of Air Spring

Top View of Air Spring Bracket



SERVICE HINT

When replacing or installing nylon air line tubing into quick-connect fittings it is critical that the end of the air line is cut square. Improper cut of the end of the air line tubing can cause the air line to seat improperly in the quick connect fitting causing air leakage.

4. Install the air line into the air spring.

WARNING

WHEN SERVICING THE VEHICLE OR ATTACHING AN AIR SPRING AND THE VEHICLE IS ON THE GROUND, PRIOR TO AIRING THE SUSPENSION SYSTEM MAKE CERTAIN THE AIR SPRING LOCATOR IS INDEXED INTO THE UPPER AIR SPRING BRACKET PROPERLY, AND THE AIR SPRING IS FULLY SEATED ON THE SPRING TOP PAD. FAILURE TO FOLLOW THESE INSTRUCTIONS CAN RESULT IN PREMATURE AIR SPRING FAILURE, CAUSE PERSONAL INJURY, OR PROPERTY DAMAGE.



AIRTEK®• SOFTEK® for Blue Bird Buses

WARNING

PRIOR TO AND DURING DEFLATION AND INFLATION OF THE FRONT AIR SUSPENSION SYSTEM, ENSURE THAT ALL PERSONNEL AND EQUIPMENT ARE CLEAR FROM UNDER THE VEHICLE AND AROUND THE SERVICE AREA, FAILURE TO DO SO CAN CAUSE SERIOUS PERSONAL INJURY, DEATH, OR PROPERTY DAMAGE.

5. See Air Spring Cautions and Warnings in the Important Safety Notice Section of this publication prior to inflating or deflating the suspension system.
6. Air up the suspension.
7. Check the air spring for leaks.
8. Check the ride height and adjust if necessary. See Preventive Maintenance Section of this publication for the proper ride height adjustment.
9. Remove the wheel chocks.

125

AIRTEK AIR SPRING – 14.6K

DISASSEMBLY

1. Place the vehicle on level floor.
2. Chock the wheels.
3. Raise the frame.
4. Support the vehicle with frame stands.

WARNING

WHEN SERVICING THE VEHICLE OR ATTACHING AN AIR SPRING AND THE VEHICLE IS ON THE GROUND, PRIOR TO AIRING THE SUSPENSION SYSTEM MAKE CERTAIN THE AIR SPRING LOCATOR IS INDEXED INTO THE UPPER AIR SPRING BRACKET PROPERLY, AND THE AIR SPRING IS FULLY SEATED ON THE SPRING TOP PAD. FAILURE TO FOLLOW THESE INSTRUCTIONS CAN RESULT IN PREMATURE AIR SPRING FAILURE, CAUSE PERSONAL INJURY, OR PROPERTY DAMAGE.

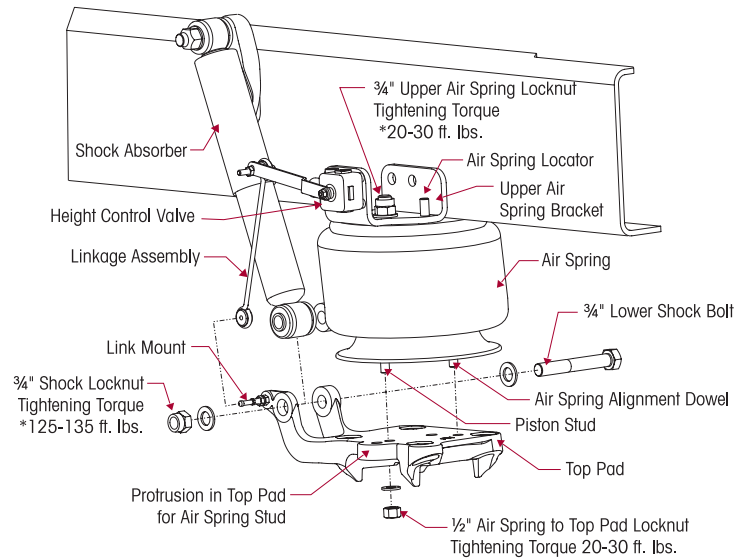
WARNING

PRIOR TO AND DURING DEFLATION AND INFLATION OF THE FRONT AIR SUSPENSION SYSTEM, ENSURE THAT ALL PERSONNEL AND EQUIPMENT ARE CLEAR FROM UNDER THE VEHICLE AND AROUND THE SERVICE AREA, FAILURE TO DO SO CAN CAUSE SERIOUS PERSONAL INJURY, DEATH, OR PROPERTY DAMAGE.

5. See Air Spring Cautions and Warnings in the Important Safety Notice Section of this publication prior to inflating or deflating the suspension system.
6. Remove the air from the air system by disconnecting the height control valve linkage(s) at the rubber grommet(s) and allowing the lever(s) to drop. This will exhaust air from the system.
7. If the air spring is damaged and the suspension is deflated, it will be necessary to raise the frame and support the vehicle with frame stands to obtain adequate clearance for air spring removal.
8. Disconnect the ¼" NPT air fitting from the air spring.
9. Remove the lower ½" air spring locknut from the piston stud to remove the air spring from the top pad, see Figure 9-9.
10. Remove the ¾" upper air spring locknut from the air spring bracket.
11. Remove the air spring.



FIGURE 9-9



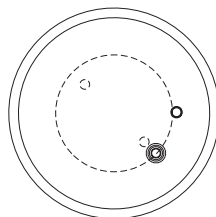
*Specification provided, controlled and subject to change by vehicle manufacturer.

ASSEMBLY

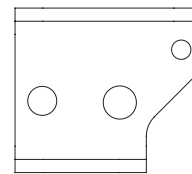
1. Compress the air spring and slide into vertical position.
2. There is a locating $\frac{1}{2}$ " stud and $\frac{3}{4}$ " threading stud on top of the air spring.
3. There are two studs on the bottom of the air spring. Guide studs through the air spring bracket and properly seat the lower air spring piston into the top axle pad. Secure the $\frac{1}{2}$ " locknut to the piston. See Figure 9-10.

FIGURE 9-10

Top View of Air Spring



Top View of Air Spring Bracket



4. Tighten the $\frac{3}{4}$ " upper air spring locknuts to vehicle manufacturer's specifications and the lower $\frac{1}{2}$ " lower air spring locknuts to 20-30 foot pounds.

WARNING

WHEN SERVICING THE VEHICLE OR ATTACHING AN AIR SPRING AND THE VEHICLE IS ON THE GROUND, PRIOR TO AIRING THE SUSPENSION SYSTEM MAKE CERTAIN THE AIR SPRING LOCATOR IS INDEXED INTO THE UPPER AIR SPRING BRACKET PROPERLY, AND THE AIR SPRING IS FULLY SEATED ON THE SPRING TOP PAD. FAILURE TO FOLLOW THESE INSTRUCTIONS CAN RESULT IN PREMATURE AIR SPRING FAILURE, CAUSE PERSONAL INJURY, OR PROPERTY DAMAGE.



AIRTEK®• SOFTEK® for Blue Bird Buses

WARNING

PRIOR TO AND DURING DEFLATION AND INFLATION OF THE FRONT AIR SUSPENSION SYSTEM, ENSURE THAT ALL PERSONNEL AND EQUIPMENT ARE CLEAR FROM UNDER THE VEHICLE AND AROUND THE SERVICE AREA, FAILURE TO DO SO CAN CAUSE SERIOUS PERSONAL INJURY, DEATH, OR PROPERTY DAMAGE.

5. See Air Spring Cautions and Warnings in the Important Safety Notice Section of this publication prior to inflating or deflating the suspension system.
6. Install the air line into the air spring.
7. Air up the suspension.
8. Check the air spring for leaks.
9. Check the ride height and adjust if necessary. See Preventive Maintenance Section of this publication for the proper ride height adjustment.
10. Remove the wheel chocks.

127

AIRTEK FRONT LEAF SPRING FRAME HANGER

DISASSEMBLY

1. Place the vehicle on level floor.
2. Chock the wheels.
3. Raise the frame.
4. Support the vehicle with frame stands.
5. Suspend the front axle from the shock absorbers.

WARNING

PRIOR TO AND DURING DEFLATION AND INFLATION OF THE FRONT AIR SUSPENSION SYSTEM, ENSURE THAT ALL PERSONNEL AND EQUIPMENT ARE CLEAR FROM UNDER THE VEHICLE AND AROUND THE SERVICE AREA, FAILURE TO DO SO CAN CAUSE SERIOUS PERSONAL INJURY, DEATH, OR PROPERTY DAMAGE.

6. See Air Spring Cautions and Warnings in the Important Safety Notice Section of this publication prior to inflating or deflating the suspension system.
7. Deflate the air springs by removing the height control valve linkage and lowering the leveling valve arm. This will exhaust the air pressure in the air springs.
8. Remove the air lines from air springs.
9. Remove the M20 spring eye bolt, washers and locknut.

SERVICE HINT

A bottle jack may be required to raise the axle slightly to facilitate removal of the spring eye bolt.

10. Remove the frame mounting fasteners from the hanger. See manufacturer's guidelines.
11. Remove the hanger from the vehicle, see Figure 9-11.

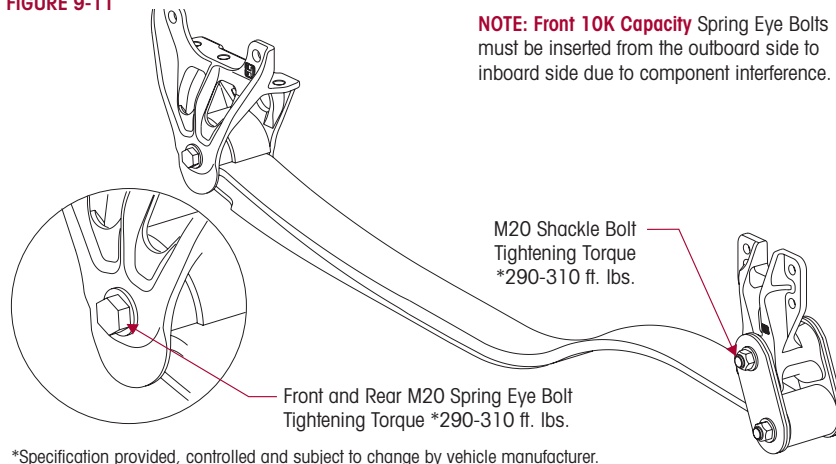
ASSEMBLY

1. Install the new hanger on the frame.
2. Install new frame fasteners. Follow manufacturer's guidelines.
3. Install the new M20 spring eye bolt from the outboard side of the hanger (see Figure 9-11), washers and locknut.

AIRTEK® • SOFTEK® for Blue Bird Buses



FIGURE 9-11



NOTE: Front 10K Capacity Spring Eye Bolts must be inserted from the outboard side to inboard side due to component interference.

*Specification provided, controlled and subject to change by vehicle manufacturer.

4. Remove the frame stands and lower frame.
5. See Air Spring Cautions and Warnings in the Important Safety Notice Section of this publication prior to inflating or deflating the suspension system.
6. Install the air lines into the air springs.
7. Install the height control valve linkage and inflate the suspension to normal operating pressure.
8. Tighten M20 locknut to vehicle manufacturer's specifications.
9. Remove the wheel chocks.

SOFTEK FRONT LEAF SPRING FRAME HANGER

DISASSEMBLY

1. Place the vehicle on level floor.
2. Chock the wheels.
3. Raise the frame.
4. Support the vehicle with frame stands.
5. Suspend the front axle from the shocks.
6. Remove the M20 spring eye bolt, washers and locknut.

SERVICE HINT

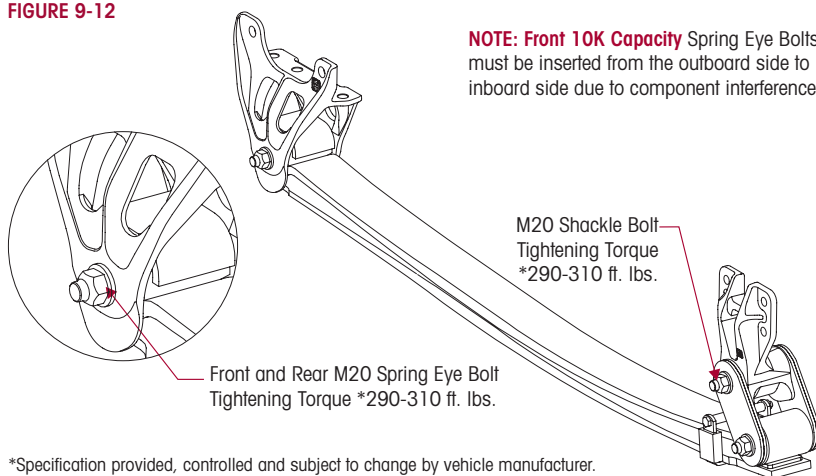
A bottle jack may be required to raise the axle slightly to facilitate removal of the spring eye bolt.

7. Remove the frame mounting fasteners from the hanger. See manufacturer's guidelines.
8. Remove the hanger from the vehicle, see Figure 9-12.



AIRTEK®• SOFTEK® for Blue Bird Buses

FIGURE 9-12



*Specification provided, controlled and subject to change by vehicle manufacturer.

ASSEMBLY

1. Install the new hanger on the frame.
2. Install new frame fasteners. Follow manufacturer's guidelines.
3. Install the new M20 spring eye bolt from the outboard side of the hanger (see Figure 9-12), washers and locknut.
4. Remove the frame stands and lower frame.
5. Tighten M20 shackle locknut to vehicle manufacturer's specifications.
6. Remove the wheel chocks.

AIRTEK REAR SHACKLE FRAME BRACKET

DISASSEMBLY

1. Place the vehicle on level floor.
2. Chock the wheels.
3. Raise the frame.
4. Support the vehicle with frame stands.
5. Suspend the front axle from the shocks.
6. See Air Spring Cautions and Warnings in the Important Safety Notice Section of this publication prior to inflating or deflating the suspension system.
7. Deflate the air springs by removing the height control valve linkage and lowering the leveling valve arm. This will exhaust the air pressure in the air springs.
8. Remove the air lines from air springs.
9. Remove the rear M20 spring eye and shackle pivot bolts, washers and locknuts.

SERVICE HINT

A bottle jack may be required to raise the axle slightly to facilitate removal of the rear spring eye bolt.

10. Remove the frame fasteners from the shackle bracket. See manufacturer's guidelines.

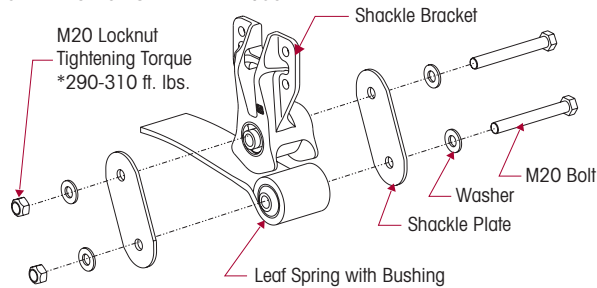
AIRTEK® • SOFTEK® for Blue Bird Buses



130

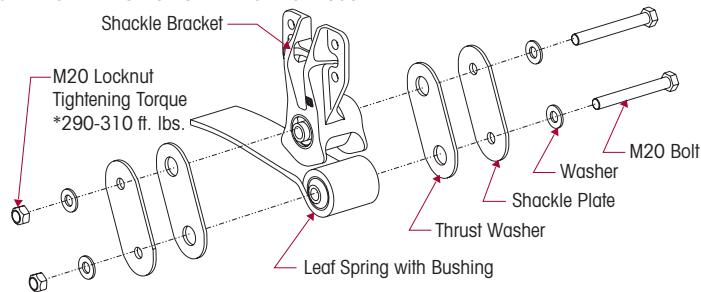
11. Remove the shackle bracket from the vehicle, see Figure 9-13 and 9-14.
12. Inspect the shackle assembly and both thrust washers (if equipped) for excessive wear or damage. See Thrust Washer Inspection in the Preventive Maintenance Section of this publication. Hendrickson recommends the thrust washers be replaced when this assembly is serviced.
13. If damaged or worn excessively, replace with Genuine Hendrickson Parts as detailed in the Component Replacement Section of this publication.

FIGURE 9-13 FOR VEHICLES BUILT AFTER 11/06



*Specification provided, controlled and subject to change by vehicle manufacturer.

FIGURE 9-14 FOR VEHICLES BUILT PRIOR TO 11/06



*Specification provided, controlled and subject to change by vehicle manufacturer.

ASSEMBLY

1. Install the shackle bracket on the frame.
2. Install new frame fasteners. Follow manufacturer's guidelines.
3. Install the thrust washers (if equipped) and shackle plates with the M20 bolts, washers and locknuts. Snug the shackle bolts. DO NOT tighten.
4. Remove the frame stands and lower frame.
5. See Air Spring Cautions and Warnings in the Important Safety Notice Section of this publication prior to inflating or deflating the suspension system.
6. Install the air lines into the air springs.
7. Install the height control valve linkage and inflate the suspension to normal ride height.
8. Tighten M20 shackle locknuts to vehicle manufacturer's specifications. See Figure 9-13 and 9-14.
9. Remove the wheel chocks.



AIRTEK®• SOFTEK® for Blue Bird Buses

SOFTEK REAR SHACKLE FRAME BRACKET

DISASSEMBLY

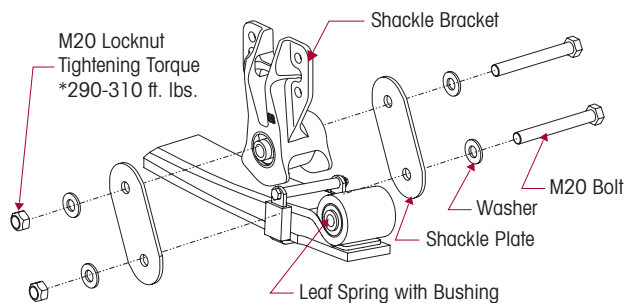
1. Place the vehicle on level floor.
2. Chock the wheels.
3. Raise the frame.
4. Support the vehicle with frame stands.
5. Suspend the front axle from the shocks.
6. Remove the rear M20 spring eye and shackle pivot bolts, washers and locknuts.

SERVICE HINT

A bottle jack may be required to raise the axle slightly to facilitate removal of the rear spring eye bolt.

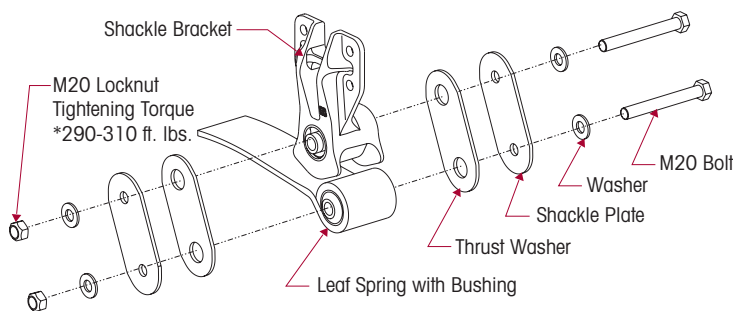
7. Remove the frame fasteners from the shackle bracket. See manufacturer's guidelines.
8. Remove the shackle bracket from the vehicle, see Figure 9-15 and 9-16.
9. Inspect the shackle assembly and both thrust washers (if equipped) for excessive wear or damage. See Thrust Washer Inspection in the Preventive Maintenance Section of this publication. Hendrickson recommends the thrust washers be replaced when this assembly is serviced.
10. If damaged or worn excessively, replace with Genuine Hendrickson Parts as detailed in the Component Replacement Section of this publication.

FIGURE 9-15 FOR VEHICLES BUILT AFTER 11/06



*Specification provided, controlled and subject to change by vehicle manufacturer.

FIGURE 9-16 FOR VEHICLES BUILT PRIOR TO 11/06



*Specification provided, controlled and subject to change by vehicle manufacturer.



ASSEMBLY

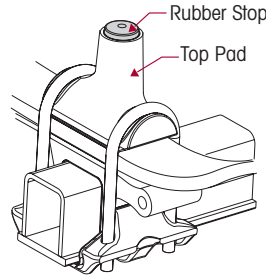
1. Install the shackle bracket on the frame.
2. Install new frame fasteners. Follow manufacturer's guidelines.
3. Install the thrust washers (if equipped) and shackle plates with the M20 bolts, washers and locknuts. See Figure 9-15 and 9-16.
4. Remove the frame stands and lower frame.
5. Tighten M20 locknuts to vehicle manufacturer's specifications.
6. Remove the wheel chocks.

SOFTEK RUBBER AXLE STOP

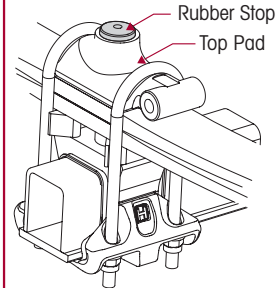
REMOVAL

1. Insert a small pry bar between the rubber stop and the inside of the top pad.
2. Apply downward force on the pry bar and pull the rubber stop out of the top pad. See Figure 9-17.

FIGURE 9-17
8K/10K



13.2K/14.6K



3. Inspect the top pad and frame rail flange for any contact damage.
4. Clean any debris from inside the top pad.

INSTALLATION

1. Lubricate the new rubber axle stop with soapy water.
2. Install the rubber axle stop in the top pad.
3. Apply downward force on the rubber axle stop until it is seated firmly in the top pad.

AIRTEK THRUST WASHERS (If Equipped)

DISASSEMBLY

1. Place the vehicle on level floor.
2. Chock the wheels.
3. Raise the frame.
4. Support the vehicle with frame stands.
5. See Air Spring Cautions and Warnings in the Important Safety Notice Section of this publication prior to inflating or deflating the suspension system.
6. Deflate the air springs by removing the height control valve linkage and lowering the leveling valve arm. This will exhaust the air pressure in the air springs.
7. Suspend the front axle from the shocks.



AIRTEK®• SOFTEK® for Blue Bird Buses

8. Remove the M20 spring eye and shackle pivot bolts, washers and locknuts.
9. Remove the shackle plates and thrust washers (if equipped).

ASSEMBLY

1. Install the NEW thrust washers (if equipped) and shackle plates with the M20 bolts, washers and locknuts. See Figure 9-13.
2. Remove frame stands and lower frame.
3. See Air Spring Cautions and Warnings in the Important Safety Notice Section of this publication prior to inflating or deflating the suspension system.
4. Install air lines into the air springs.
5. Install the height control valve linkage and inflate the suspension to normal ride height.
6. Tighten M20 locknuts to vehicle manufacturer's specifications.
7. Remove the wheel chocks.

SOFTEK THRUST WASHERS (If Equipped)

DISASSEMBLY

1. Place the vehicle on level floor.
2. Chock the wheels.
3. Raise the frame.
4. Support the vehicle with frame stands.
5. Suspend the front axle from the shocks.
6. Remove the M20 spring eye and shackle pivot bolts, washers and locknuts.
7. Remove the shackle plates and thrust washers (if equipped).

ASSEMBLY

1. Install the NEW thrust washers (if equipped) and shackle plates with the M20 bolts, washers and locknuts. See Figure 9-15.
2. Remove frame stands and lower frame.
3. Tighten M20 locknuts to vehicle manufacturer's specifications.
4. Remove the wheel chocks.



AIRTEK LEAF SPRING ASSEMBLY

DISASSEMBLY

1. Place the vehicle on a level floor.
2. Chock the wheels.
3. Raise the frame.
4. Support the vehicle with frame stands.
5. See Air Spring Cautions and Warnings in the Important Safety Notice Section of this publication prior to inflating or deflating the suspension system.
6. Deflate the air springs by removing the height control valve linkage and lowering the height control valve arm. This will exhaust the air pressure in the air springs.

CAUTION

THE PUSH-TO-CONNECT FITTINGS ARE NON-SERVICEABLE. IT IS NECESSARY TO CLEAN THE DIRT AND DEBRIS AWAY FROM THE PUSH-TO-CONNECT FITTINGS AND THE AIR LINES TO HELP PREVENT ANY FOREIGN MATERIAL FROM ENTERING THE AIR SPRING, AIR SYSTEM OR DAMAGING THE PUSH-TO-CONNECT FITTINGS. CLEAN PUSH-TO-CONNECT FITTINGS USING SOAPY WATER AND A SOFT BRISTLED BRUSH AND DRY WITH COMPRESSED AIR.

7. Disconnect the air lines at the air springs.
8. Suspend the front axle to remove the load from leaf spring assembly.
9. Remove the air spring (see Air Spring disassembly in this section).
10. Remove the front and rear M20 spring eye bolts washer and locknuts. Loosen the M20 shackle pivot bolt.

SERVICE HINT

To ease in the removal of the spring eye bolts, it may be necessary to raise the axle slightly.

11. Remove the 3/4" clamp group locknuts and discard.

WARNING

DO NOT USE A CUTTING TORCH TO REMOVE CLAMP GROUP BOLTS OR ATTACHING FASTENERS. THE USE OF SUCH HEAT ON SUSPENSION COMPONENTS CAN ADVERSELY AFFECT THE STRENGTH OF THESE PARTS. A COMPONENT DAMAGED IN THIS MANNER CAN RESULT IN THE LOSS OF VEHICLE CONTROL AND POSSIBLE PERSONAL INJURY OR PROPERTY DAMAGE.

SERVICE HINT

If a clamp group nut fails to come off bolt, cut half way through the bolt with an abrasive cut off wheel, taking care not to contact axle beam or other components. Using an impact wrench, spin the locknut to fracture the bolt and remove.

12. Remove the 3/4" clamp group bolts, the top pad, galvanized liner and the bottom axle wrap and liner. Discard the clamp group bolts. See Figure 9-18.
13. Remove the spring assembly.

ASSEMBLY

1. Install the new spring and wrap leaf assembly on the axle. Verify the center bolt is located properly in the top axle wrap and spacer (if equipped). See Figure 9-18.
2. Install the new galvanized liner and the top pad onto the spring.
3. Remove and replace the bottom axle wrap liner located in bottom axle wrap.

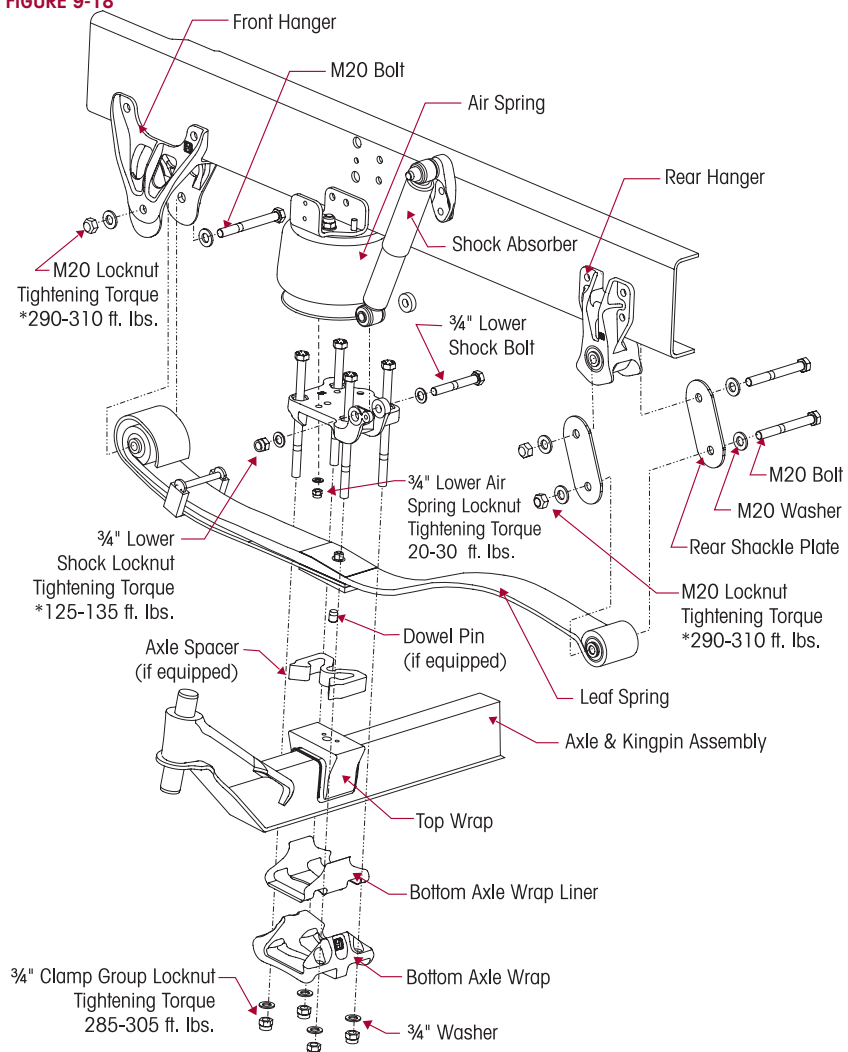




AIRTEK® • SOFTEK® for Blue Bird Buses

135

FIGURE 9-18



*Specification provided, controlled and subject to change by vehicle manufacturer.

4. Install the bottom axle wrap.
5. Install the new $\frac{3}{4}$ " clamp group bolts, washers, and locknuts. New clamp group fasteners must be used when the clamp group is removed, to prevent premature bolt fatigue.
6. Snug the clamp group, DO NOT torque at this time.
7. Raise the axle and the spring assembly into the front hanger and rear shackle assembly.
8. Install the M20 spring eye bolts, washers and locknuts. Snug bolts. Do not tighten.
9. Ensure that the clamp group is properly aligned and the hex bolts are seated in the top pad, and the bottom axle wrap is centered with the top axle wrap. See Figure 9-19.

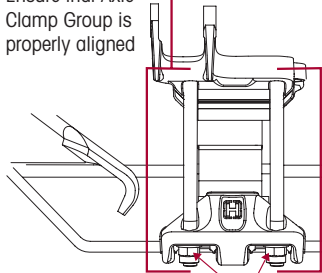
AIRTEK® • SOFTEK® for Blue Bird Buses



FIGURE 9-19

IMPORTANT

Ensure that Axle Clamp Group is properly aligned



¾" Clamp Group Locknuts
Tightening Torque 285-305 ft. lbs.

IMPORTANT

Ensure that the ¾" Clamp Bolts are seated properly in the Top Pad

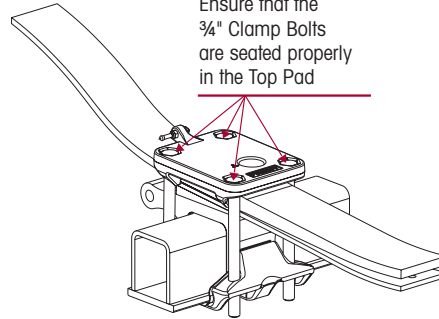
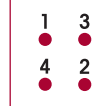
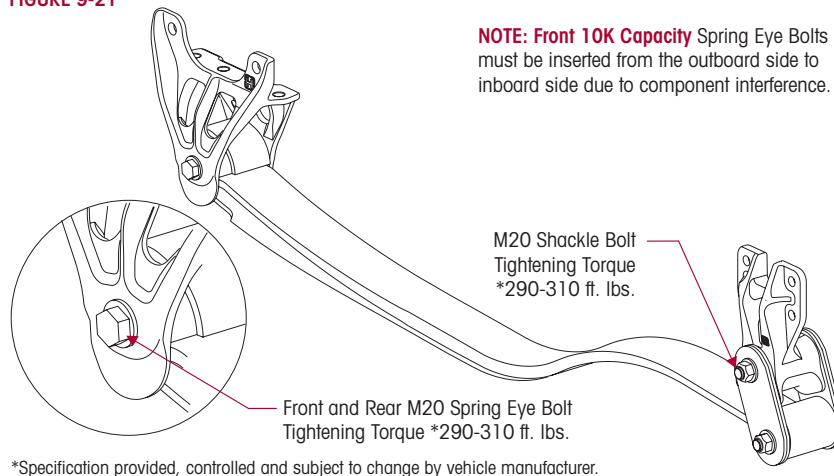


FIGURE 9-20



10. Tighten the clamp group locknuts evenly in 50 foot pounds increments to 285-305 foot pounds torque in the proper pattern to achieve uniform bolt tension, see Figure 9-20.
11. See Air Spring Cautions and Warnings in the Important Safety Notice Section of this publication prior to inflating or deflating the suspension system.
12. Install air spring.
13. Install air lines, and air up system.
14. Remove the frame supports and load the front axle with the vehicle weight.
15. Verify proper ride height. See Alignment & Adjustments Section of this publication.
16. Tighten the M20 spring eye bolt locknuts to vehicle manufacturer's specifications. See Figure 9-21.

FIGURE 9-21





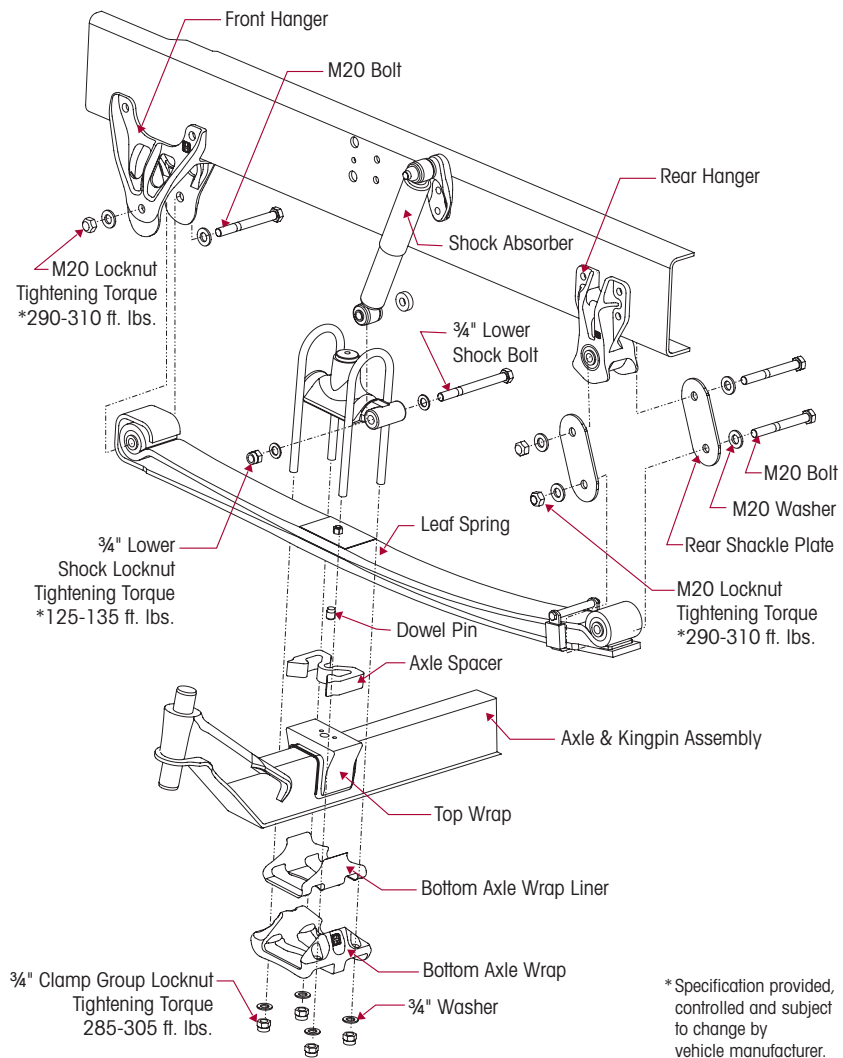
AIRTEK® • SOFTEK® for Blue Bird Buses

SOFTEK LEAF SPRING ASSEMBLY

DISASSEMBLY

1. Place the vehicle on a level floor.
2. Chock the wheels.
3. Raise the vehicle.
4. Support the vehicle with frame stands.
5. Suspend the front axle to remove the load from leaf spring assembly.
6. Remove the front and rear M20 spring eye bolts washer and locknuts. Loosen the M20 shackle pivot bolt.

FIGURE 9-22



AIRTEK® • SOFTEK® for Blue Bird Buses



SERVICE HINT

To ease in the removal of the spring eye bolts, it may be necessary to raise the axle slightly.

7. Remove the 3/4" clamp group U-bolts, washers and locknuts. Discard the fasteners.

WARNING

DO NOT USE A CUTTING TORCH TO REMOVE CLAMP GROUP BOLTS OR ATTACHING FASTENERS. THE USE OF SUCH HEAT ON SUSPENSION COMPONENTS CAN ADVERSELY AFFECT THE STRENGTH OF THESE PARTS. A COMPONENT DAMAGED IN THIS MANNER CAN RESULT IN THE LOSS OF VEHICLE CONTROL AND POSSIBLE PERSONAL INJURY OR PROPERTY DAMAGE.

SERVICE HINT

If a clamp group nut fails to come off bolt, cut half way through the bolt with an abrasive cut off wheel, taking care not to contact axle beam or other components. Using an impact wrench, spin the locknut to fracture the bolt and remove.

8. Remove the top pad, galvanized liner and the bottom axle wrap. See Figure 9-22.

9. Remove the spring assembly.

ASSEMBLY

1. Install the new spring and wrap leaf assembly on the axle. Verify that the center bolt is located properly in the top axle wrap and spacer (if equipped). See Figure 9-22.

2. Install the new galvanized liner and the top pad onto the spring.

3. Remove and replace the bottom axle wrap liner located in bottom axle wrap.

4. Install the bottom axle wrap.

5. Install the new 3/4" clamp group U-bolts, washers, and locknuts. The locknuts must be replaced when the clamp group is removed, to prevent premature bolt fatigue.

6. Snug the clamp group, **DO NOT** torque at this time.

7. Raise the axle and the spring and wrap leaf assembly into the front hanger and rear shackle assembly.

8. Install the M20 spring eye bolts, washers and locknuts. Snug bolts. Do not tighten.

9. Ensure that the clamp group is properly aligned and the U-bolts are seated in the top pad, and the bottom axle wrap is centered with the top axle wrap. See Figure 9-23.

FIGURE 9-23

IMPORTANT
Ensure that Axle Clamp Group is properly aligned

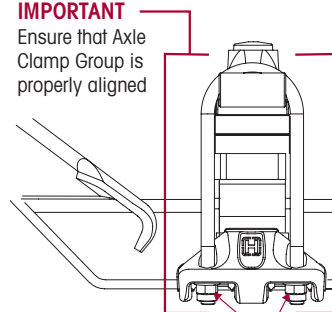
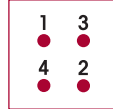


FIGURE 9-24



10. Tighten the clamp group locknuts evenly in 50 foot pounds increments to 285-305 foot pounds torque in the proper pattern to achieve uniform bolt tension, see Figure 9-24.

3/4" Clamp Group Locknuts
Tightening Torque 285-305 ft. lbs.

11. Remove the frame supports and load the front axle with the vehicle weight.

12. Tighten the M20 spring eye bolt locknuts to vehicle manufacturer's specifications.



AIRTEK®• SOFTEK® for Blue Bird Buses

139

FRONT LEAF SPRING EYE BUSHINGS

The spring eye bushings for the AIRTEK and SOFTEK spring and wrap leaf assemblies are designed to provide extended service life. If premature wear occurs careful consideration must be given to the contributing factor that caused the wear. This must be corrected in order to prevent the new bushing from wearing in the same manner. The front and rear bushings are permanently installed in the spring leaf and are not serviceable. If a bushing wears prematurely, the spring and wrap leaf assembly must be replaced. Follow the procedure for the Front Leaf Spring removal in the Component Replacement Section of this publication.

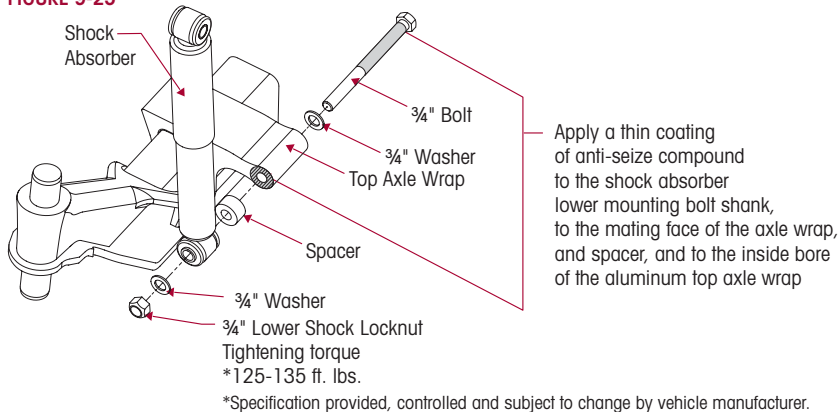
AIRTEK/SOFTEK SHOCK ABSORBER – VISION (8K/10K)

It is not necessary to replace shock absorbers in pairs if only one shock requires replacement.

DISASSEMBLY

1. Remove the $\frac{3}{4}$ " lower mounting bolt, fasteners, and spacer.
2. Remove the $\frac{3}{4}$ " upper mounting bolt and fasteners.
3. Slide the shock absorber out of the upper bracket and off of the lower mounting bolt.
4. Inspect the shock absorber mounting brackets and hardware for damage or wear, replace as necessary.

FIGURE 9-25



ASSEMBLY

1. Install the shock absorber into the upper mounting bracket.
2. Install the upper $\frac{3}{4}$ " shock mounting bolt, washers and locknut.
3. Apply a thin coating of anti-seize compound to the shock absorber lower mounting bolt shank, to the mating face of the axle wrap and spacer, and to the inside bore of the aluminum axle wrap. This is necessary to help prevent seizing of the bolt to the aluminum axle wrap.
4. Install the lower $\frac{3}{4}$ " bolt from the inboard side to the outboard side of the top axle wrap and attach the spacer, washer, and locknut. See Figure 9-25.
5. Tighten both upper and lower $\frac{3}{4}$ " locknuts to vehicle manufacturer's specifications. See Figure 9-25.

AIRTEK® • SOFTEK® for Blue Bird Buses



140

AIRTEK/SOFTEK SHOCK ABSORBER – ALL AMERICAN (13.2K/14.6K)

It is not necessary to replace shock absorbers in pairs if only one shock requires replacement.

DISASSEMBLY

1. Remove the 3/4" lower mounting bolt, fasteners, and spacer.
2. Remove the 3/4" upper mounting bolt and fasteners.
3. Slide the shock absorber out of the lower bracket and off of the lower mounting bolt.
4. Inspect the shock absorber mounting brackets and hardware for damage or wear, replace as necessary.

FIGURE 9-26
AIRTEK 14.6K

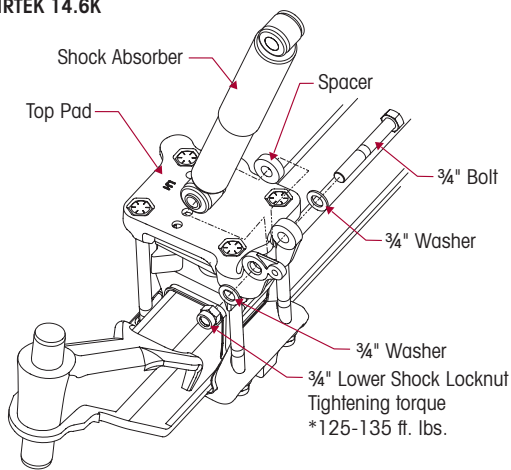
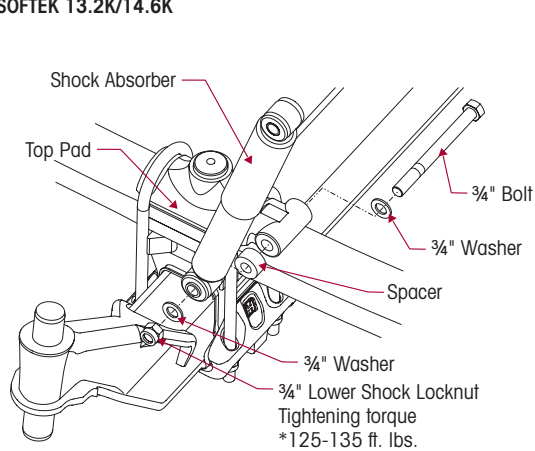


FIGURE 9-27
SOFTEK 13.2K/14.6K



*Specification provided, controlled and subject to change by vehicle manufacturer.

ASSEMBLY

1. Install the shock absorber into the upper mounting bracket.
2. Install the upper 3/4" shock mounting bolt, washers and locknut.
3. Install the lower 3/4" bolt from the inboard side to the outboard side of the top axle wrap and attach the spacer, washer, and locknut. See Figure 9-26 and 9-27.
4. Tighten both upper and lower 3/4" locknuts to vehicle manufacturer's specifications. See Figure 9-26 and 9-27.



AIRTEK®• SOFTEK® for Blue Bird Buses

141

AIRTEK BOTTOM AXLE WRAP

DISASSEMBLY

1. Place the vehicle on level floor.
2. Chock the wheels.
3. Raise the frame.
4. Support the vehicle with frame stands.
5. See Air Spring Cautions and Warnings in the Important Safety Notice Section of this publication prior to inflating or deflating the suspension system.
6. Deflate the air springs by disconnecting the height control valve linkage and lowering the height control valve arm. This will exhaust the air pressure in the air springs.

WARNING

DO NOT USE A CUTTING TORCH TO REMOVE CLAMP GROUP BOLTS OR ATTACHING FASTENERS. THE USE OF SUCH HEAT ON SUSPENSION COMPONENTS CAN ADVERSELY AFFECT THE STRENGTH OF THESE PARTS. A COMPONENT DAMAGED IN THIS MANNER CAN RESULT IN THE LOSS OF VEHICLE CONTROL AND POSSIBLE PERSONAL INJURY OR PROPERTY DAMAGE.

SERVICE HINT

If a clamp group nut fails to come off bolt, cut half way through the bolt with an abrasive cut off wheel, taking care not to contact axle beam or other components. Using an impact wrench, spin the locknut to fracture the bolt and remove.

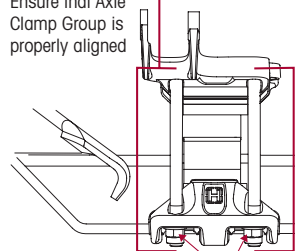
7. Remove $\frac{3}{4}$ " hex bolts, washers and locknuts. Removal of the air spring will be required. See Air Spring Replacement instructions in this section. Discard fasteners.
8. Remove bottom axle wrap. It may be necessary to use a dead blow mallet to dislodge axle wrap.
9. Once removed inspect axle wrap for damage. Replace if necessary.
10. Discard used bottom axle wrap liner.

ASSEMBLY

1. Install new bottom axle wrap liner into bottom axle wrap.
2. Install bottom axle wrap on axle.
3. Install new $\frac{3}{4}$ " clamp group bolts, washers and locknuts. Ensure that the clamp group is properly aligned and the hex bolts are seated in the top pad, and the bottom axle wrap is centered on the top axle wrap. See Figure 9-28.

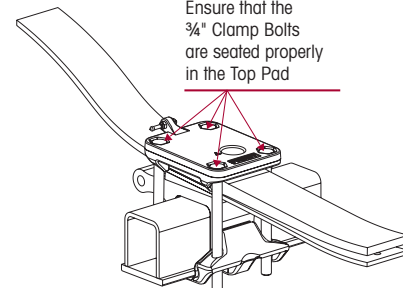
FIGURE 9-28 AIRTEK

IMPORTANT
Ensure that Axle
Clamp Group is
properly aligned



$\frac{3}{4}$ " Clamp Group Locknuts
Tightening Torque 285-305 ft. lbs.

IMPORTANT
Ensure that the
 $\frac{3}{4}$ " Clamp Bolts
are seated properly
in the Top Pad

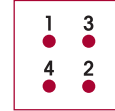


AIRTEK® • SOFTEK® for Blue Bird Buses



4. Tighten locknuts evenly to 285-305 foot pounds torque. See Figure 9-29 for proper torque sequence.
5. Install Air spring. See Air Spring assembly in the Component Replacement section of this publication.
6. Remove the wheel chocks.

FIGURE 9-29



SOFTEK BOTTOM AXLE WRAP

DISASSEMBLY

1. Place the vehicle on level floor.
2. Chock the wheels.
3. Raise the frame.
4. Support the vehicle with frame stands.



WARNING

DO NOT USE A CUTTING TORCH TO REMOVE CLAMP GROUP BOLTS OR ATTACHING FASTENERS. THE USE OF SUCH HEAT ON SUSPENSION COMPONENTS CAN ADVERSELY AFFECT THE STRENGTH OF THESE PARTS. A COMPONENT DAMAGED IN THIS MANNER CAN RESULT IN THE LOSS OF VEHICLE CONTROL AND POSSIBLE PERSONAL INJURY OR PROPERTY DAMAGE.

SERVICE HINT

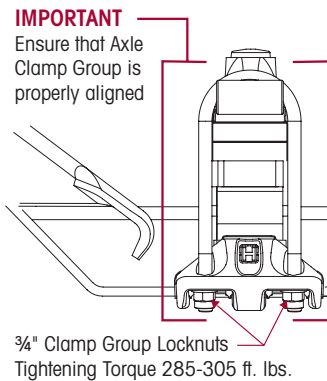
If a clamp group nut fails to come off bolt, cut half way through the bolt with an abrasive cut off wheel, taking care not to contact axle beam or other components. Using an impact wrench, spin the locknut to fracture the bolt and remove.

5. Remove 3/4" U-bolts, washers and locknuts. Discard fasteners.
6. Remove bottom axle wrap. It may be necessary to use a dead blow mallet to dislodge axle wrap.
7. Once removed inspect axle wrap for damage. Replace if necessary.
8. Discard used bottom axle wrap liner.

ASSEMBLY

1. Install new bottom axle wrap liner into bottom axle wrap.
2. Install bottom axle wrap on axle.
3. Install new 3/4" U-bolts, washers and locknuts. Ensure that the clamp group is properly aligned and the U-bolts are seated in the top pad, and the bottom axle wrap is centered with the top axle wrap. See Figure 9-30.
4. Tighten locknuts evenly to 285-305 foot pounds torque. See Figure 9-29 for proper torque sequence.
5. Remove the wheel chocks.

FIGURE 9-30 SOFTEK





AIRTEK®• SOFTEK® for Blue Bird Buses

143

AIRTEK TOP AXLE WRAP (In Chassis)

DISASSEMBLY

1. Place the vehicle on level floor.
2. Chock the wheels.
3. Raise the frame.
4. Support the vehicle with frame stands.
5. Suspend the front axle to remove the load from the spring and wrap leaf assembly.
6. See Air Spring Cautions and Warnings in the Important Safety Notice Section of this publication prior to inflating or deflating the suspension system.

DANGER

AIR SPRINGS MUST BE DEFLATED PRIOR TO LOOSENING ANY CLAMP GROUP HARDWARE. UNCONSTRAINED AIR SPRINGS CAN VIOLENTLY SHIFT, RESULTING IN POSSIBLE PERSONAL INJURY, DEATH OR PROPERTY DAMAGE.

7. Deflate the air springs by disconnecting the height control valve linkage and lowering the height control valve arm. This will exhaust the air pressure in the air springs.
8. Disconnect the air lines at the air springs.
9. Remove the air spring (See Air Spring disassembly in the Component Replacement Section of this publication).
10. Support the axle with a jack.
11. Remove the front and rear M20 spring eye bolts, washers and locknuts.

SERVICE HINT

A bottle jack may be required to raise the axle slightly in order to remove spring eye bolts.

WARNING

DO NOT USE A CUTTING TORCH TO REMOVE CLAMP GROUP BOLTS OR ATTACHING FASTENERS. THE USE OF SUCH HEAT ON SUSPENSION COMPONENTS CAN ADVERSELY AFFECT THE STRENGTH OF THESE PARTS. A COMPONENT DAMAGED IN THIS MANNER CAN RESULT IN THE LOSS OF VEHICLE CONTROL AND POSSIBLE PERSONAL INJURY OR PROPERTY DAMAGE.

SERVICE HINT

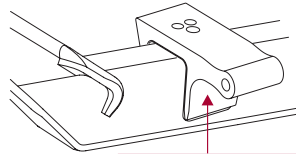
If a clamp group nut fails to come off bolt, cut half way through the bolt with an abrasive cut off wheel, taking care not to contact axle beam or other components. Using an impact wrench, spin the locknut to fracture the bolt and remove.

12. Remove the 3/4" clamp group bolts, washers and locknuts. Discard fasteners.
13. Remove the top pad, the galvanized liner, and the bottom axle wrap.
14. Remove the lower shock mounting bolt.
15. Remove the spring and wrap leaf assembly
16. Strike the axle wrap with a dead blow mallet at the front and rear on the underside of the axle wrap to dislodge it from the axle. See Figure 9-31.
17. Clean and inspect the axle wrap and axle wrap line for cracks or damage, replace each if cracks or damage are present.

AIRTEK® • SOFTEK® for Blue Bird Buses

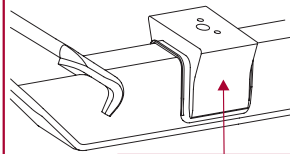


FIGURE 9-31
AIRTEK 10K



Carefully strike upward with a dead blow mallet on both ends

AIRTEK 14.6K



Carefully strike upward with a dead blow mallet on both ends

ASSEMBLY

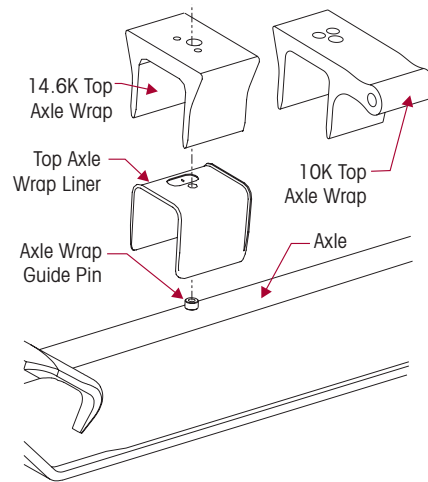
1. Install the new axle wrap liner on the axle.
2. Spray the axle wrap liner and the axle wrap with a silicon lubricant.
3. Position the axle wrap on the axle, see Figure 9-32.

CAUTION

DO NOT STRIKE THE TOP AXLE WRAP WITH A HAMMER. HENDRICKSON RECOMMENDS USING A PLASTIC DEAD BLOW MALLET WITH CARE WHEN INSTALLING THE AXLE WRAP.

4. Protect the top surface of the axle wrap with a block of wood, cardboard, or shop towels.
5. Install a bottle jack between the axle wrap and frame rail flange.
6. Jack the axle wrap down into position on the axle, using care to make sure the axle wrap bore indexes the locating bushing on the axle.

FIGURE 9-32



IMPORTANT NOTE

For Flat Floor Models install the intermediate dowel pin into the axle wrap.

7. Install the spring and wrap leaf assembly on the axle wrap (indexing the dowel pin if equipped).
8. Install the galvanized liner and the top pad on the spring and wrap leaf assembly.
9. Remove and replace the bottom axle wrap liner.
10. Install the bottom axle wrap.
11. Install the new 3/4" clamp group bolts, washers, and locknuts.
12. Snug the clamp group, **DO NOT** torque at this time.
13. Use a jack and raise the axle and spring assembly into the front spring hanger and shackle assembly.

SERVICE HINT

A bottle jack may be required to raise the axle slightly in order to install the spring eye bolts.

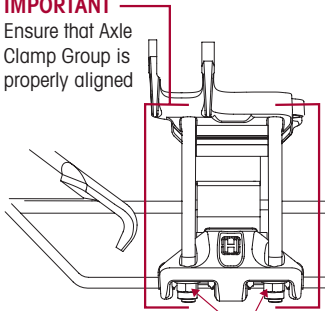
14. Install the M20 spring eye bolts in the front spring hanger and rear shackle assembly.
15. Ensure that the clamp group is properly aligned and the hex bolts are seated in the top pad, and the bottom axle wrap is centered with the top axle wrap. See Figure 9-33.



AIRTEK®• SOFTEK® for Blue Bird Buses

FIGURE 9-33

IMPORTANT
Ensure that Axle Clamp Group is properly aligned



3/4" Clamp Group Locknuts
Tightening Torque 285-305 ft. lbs.

IMPORTANT

Ensure that the 3/4" Clamp Bolts are seated properly in the Top Pad

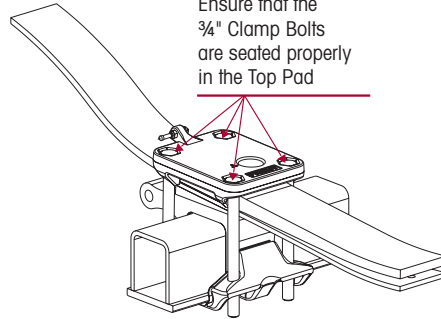
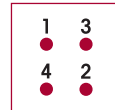


FIGURE 9-34



16. Tighten the 3/4" clamp group locknuts evenly to 285-305 foot pounds torque in the proper sequence, see Figure 9-34.

17. Remove the jack from the axle.

18. Remove the frame stands.

19. See Air Spring Cautions and Warnings in the Important Safety Notice Section of this publication prior to inflating or deflating the suspension system.

20. Attach air lines to the air springs.

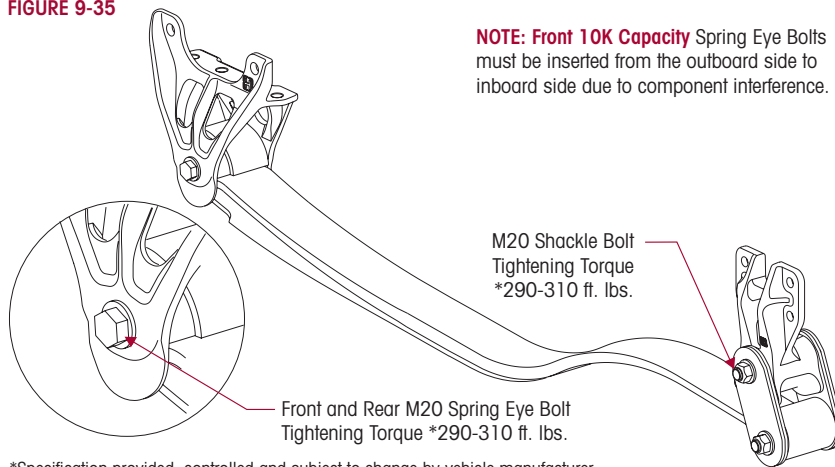
21. Install shocks. (See shock absorber assembly in this section)

22. Air up system to proper ride height. (See Ride Height Adjustment in the Alignment & Adjustments Section of this publication).

23. Tighten the M20 spring eye bolt locknuts to vehicle manufacturer's specifications. See Figure 9-35.

24. Remove the wheel chocks.

FIGURE 9-35



NOTE: Front 10K Capacity Spring Eye Bolts must be inserted from the outboard side to inboard side due to component interference.

M20 Shackle Bolt
Tightening Torque
*290-310 ft. lbs.

Front and Rear M20 Spring Eye Bolt
Tightening Torque *290-310 ft. lbs.

*Specification provided, controlled and subject to change by vehicle manufacturer.



SOFTEK TOP AXLE WRAP (In Chassis)

DISASSEMBLY

1. Place the vehicle on level floor.
2. Chock the wheels.
3. Raise the frame.
4. Support the vehicle with frame stands.
5. Suspend the front axle to remove the load from the spring and wrap leaf assembly.
6. Remove the front and rear M20 spring eye bolts, washers and locknuts. Loosen the M20 shackle pivot bolt.

SERVICE HINT

A bottle jack may be required to raise the axle slightly in order to remove spring eye bolts.

7. Support the axle with a jack.



WARNING

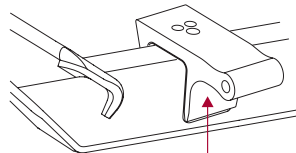
DO NOT USE A CUTTING TORCH TO REMOVE CLAMP GROUP BOLTS OR ATTACHING FASTENERS. THE USE OF SUCH HEAT ON SUSPENSION COMPONENTS CAN ADVERSELY AFFECT THE STRENGTH OF THESE PARTS. A COMPONENT DAMAGED IN THIS MANNER CAN RESULT IN THE LOSS OF VEHICLE CONTROL AND POSSIBLE PERSONAL INJURY OR PROPERTY DAMAGE.

SERVICE HINT

If a clamp group nut fails to come off bolt, cut half way through the bolt with an abrasive cut off wheel, taking care not to contact axle beam or other components. Using an impact wrench, spin the locknut to fracture the bolt and remove.

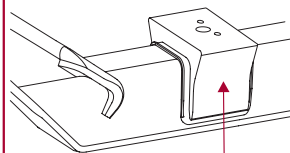
8. Remove the 3/4" clamp group U-bolts, washers and locknuts. Discard fasteners.
9. Remove the top pad and the bottom axle wrap.
10. Remove the lower shock mounting bolt.
11. Remove the spring and wrap leaf assembly.
12. Strike the axle wrap with a dead blow mallet at the front and rear on the underside of the axle wrap to dislodge it from the axle. See Figure 9-36.
13. Clean and inspect the axle wrap and axle wrap liners for cracks or damage, replace each if cracks or damage are present.

FIGURE 9-36
SOFTEK 8K/10K



Carefully strike upward with a dead blow mallet on both ends

SOFTEK 13.2K/14.6K



Carefully strike upward with a dead blow mallet on both ends

ASSEMBLY

1. Install the new axle wrap liner on the axle.
2. Spray the axle wrap liner and the axle wrap with a silicon lubricant.
3. Position the axle wrap on the axle, see Figure 9-37.



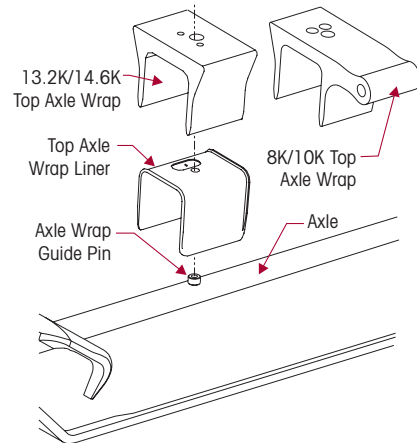
AIRTEK® • SOFTEK® for Blue Bird Buses

CAUTION

DO NOT STRIKE THE TOP AXLE WRAP WITH A HAMMER. HENDRICKSON RECOMMENDS USING A PLASTIC DEAD BLOW Mallet WITH CARE WHEN INSTALLING THE AXLE WRAP.

4. Protect the top surface of the axle wrap with a block of wood, cardboard, or shop towels.
5. Install a bottle jack between the axle wrap and frame rail flange.
6. Jack the axle wrap down into position on the axle, using care to make sure the axle wrap bore indexes the locating bushing on the axle.
7. Install the spring and wrap leaf assembly on the axle wrap indexing the center bolt in the locating hole.
8. Install the top pad on the spring and wrap leaf assembly.
9. Remove and replace the bottom axle wrap liner.
10. Install the bottom axle wrap.
11. Install the new $\frac{3}{4}$ " clamp group U-bolts, washers, and locknuts.
12. Snug the clamp group, **DO NOT** torque at this time.
13. Use a jack and raise the axle and spring assembly into the front spring hanger and shackle assembly.

FIGURE 9-37

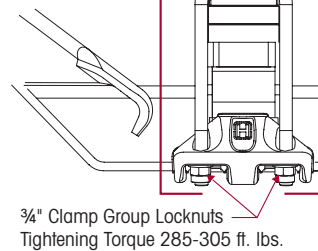

SERVICE HINT

A bottle jack may be required to raise the axle slightly in order to install the spring eye bolts.

14. Install the M20 spring eye bolts, washer and locknuts in the front spring hanger and rear shackle assembly.
15. Ensure that the clamp group is properly aligned and the U-bolts are seated in the top pad, and the bottom axle wrap is centered with the top axle wrap. See Figure 9-38.

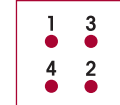
FIGURE 9-38 SOFTEK IMPORTANT

Ensure that Axle Clamp Group is properly aligned



16. Tighten the $\frac{3}{4}$ " clamp group locknuts evenly to \mathbb{N} 285-305 foot pounds torque in the proper sequence, see Figure 9-39.
17. Apply a thin coating of anti-seize to the lower shock mounting bolt.
18. Install shocks. (See shock absorber assembly in this section)
19. Remove the jack from the axle.
20. Remove the frame stands.
21. Tighten the M20 spring eye bolt locknuts to vehicle manufacturer's specifications.
22. Remove the wheel chocks.

FIGURE 9-39



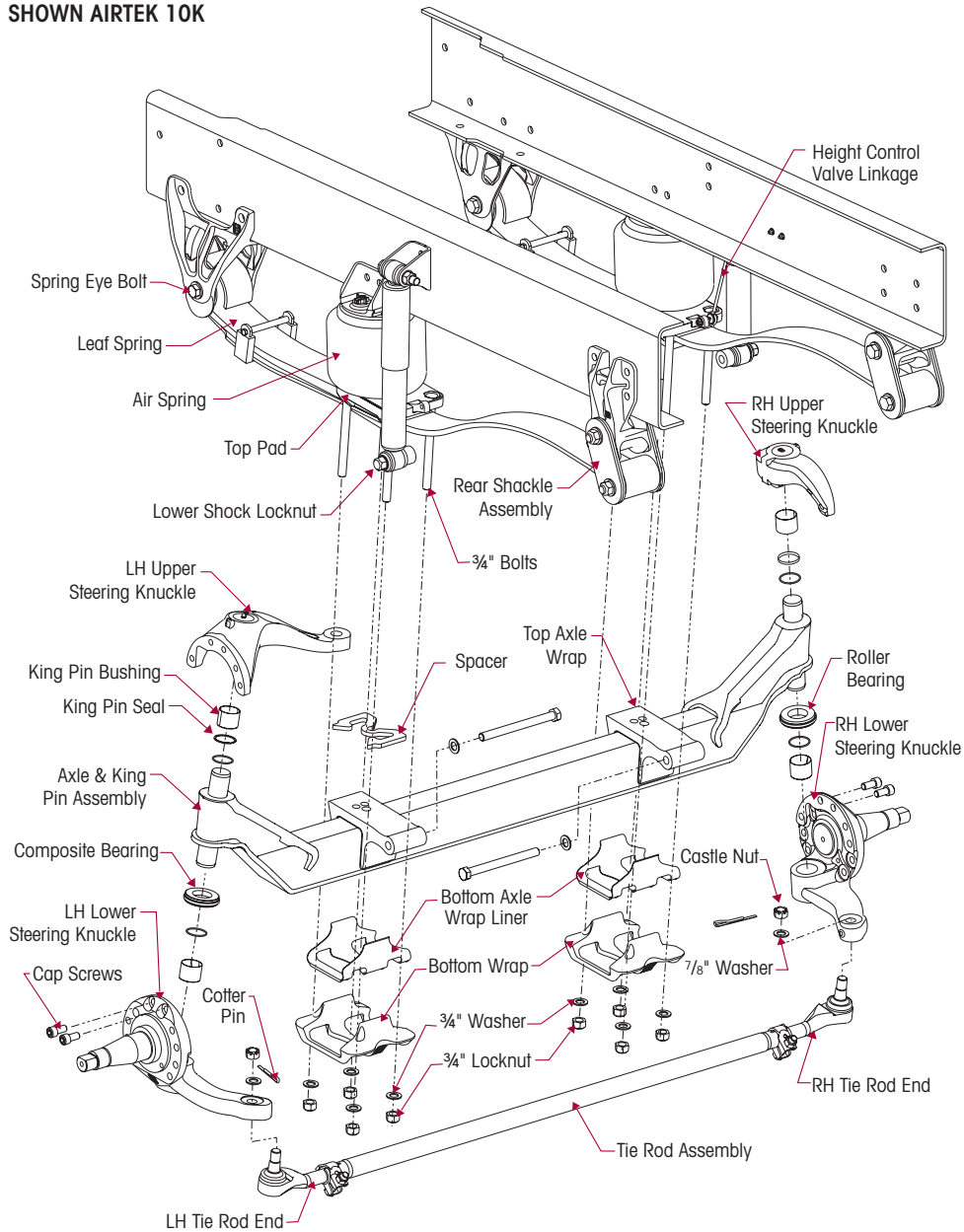


AIRTEK FRONT AXLE ASSEMBLY

STEERTEK AXLE CLAMP GROUP CONSIST OF THE FOLLOWING COMPONENTS:

- Top axle wrap
- Top axle wrap liner
- Top pad
- Bottom axle wrap
- Bottom axle wrap liner
- 3/4" Bolts, washers and nylon locknuts

FIGURE 9-40
SHOWN AIRTEK 10K





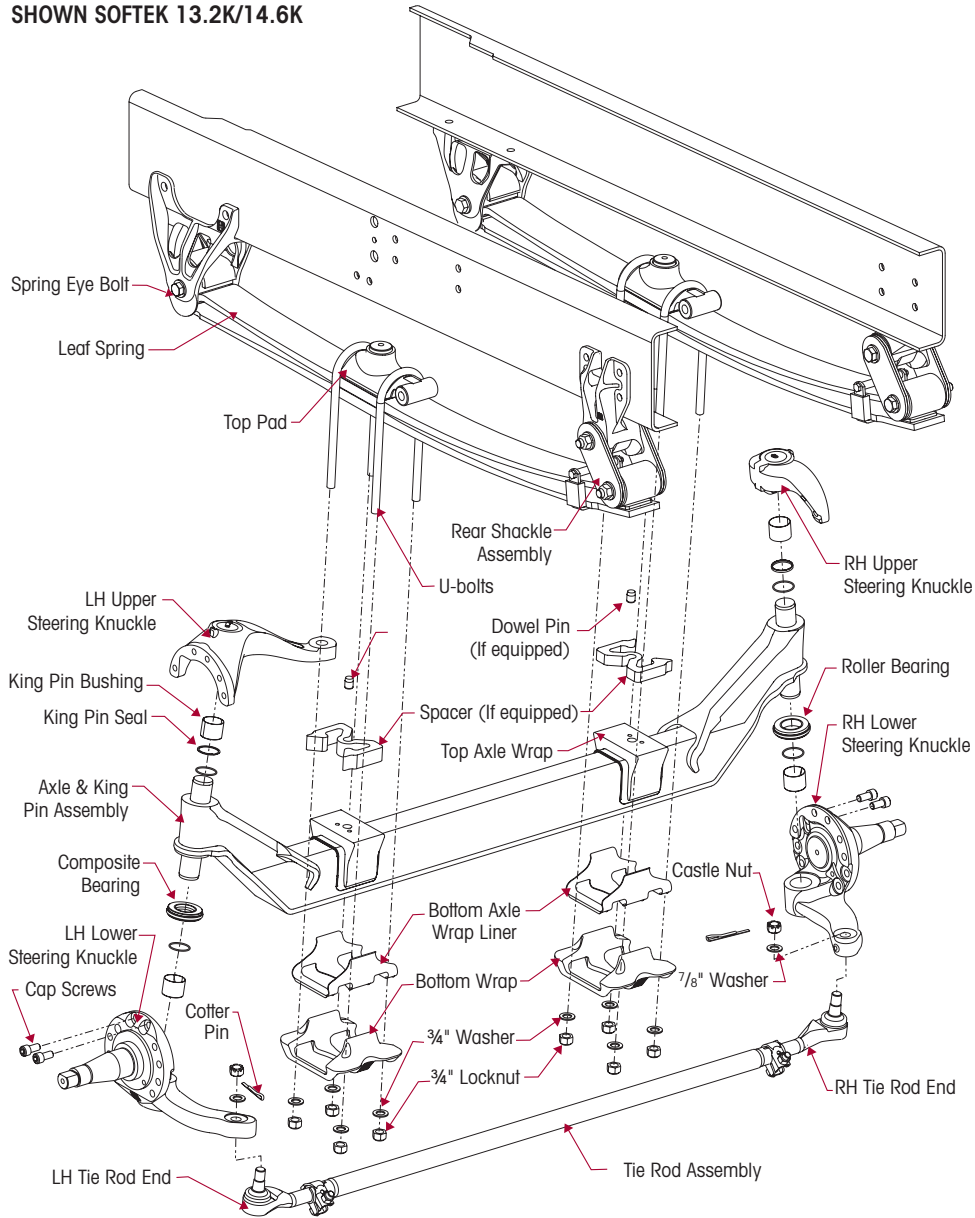
AIRTEK®• SOFTEK® for Blue Bird Buses

SOFTEK FRONT AXLE ASSEMBLY

STEERTEK AXLE CLAMP GROUP CONSIST OF THE FOLLOWING COMPONENTS:

- Top axle wrap
- Top axle wrap liner
- Top pad
- Bottom axle wrap
- Bottom axle wrap liner
- 3/4" Bolts, washers and nylon locknuts

FIGURE 9-41
SHOWN SOFTEK 13.2K/14.6K



AIRTEK® • SOFTEK® for Blue Bird Buses



150

STEERTEK AXLE REMOVAL

Refer to Figure 9-40 and 9-41 when replacing the components of the STEERTEK axle.

WARNING

DO NOT USE A TORCH ON CLAMP GROUP BOLTS OR ANY OTHER PART OF THE AIRTEK SUSPENSION. IF THE CLAMP GROUP BOLTS WILL NOT COME LOOSE WITH AN IMPACT WRENCH, USE A CUT OFF WHEEL AND CUT THE SHANK OF THE BOLT. THE USE OF A TORCH CAN CAUSE DAMAGE TO CERTAIN AIRTEK COMPONENTS THAT CAN RESULT IN THE LOSS OF VEHICLE CONTROL AND POSSIBLE PERSONAL INJURY OR PROPERTY DAMAGE.

1. Place the vehicle on level floor.
2. Chock the wheels.
3. SOFTEK equipped vehicles — proceed to step 6.

WARNING

PRIOR TO AND DURING DEFLATION AND INFLATION OF THE FRONT AIR SUSPENSION SYSTEM, ENSURE THAT ALL PERSONNEL AND EQUIPMENT ARE CLEAR FROM UNDER THE VEHICLE AND AROUND THE SERVICE AREA, FAILURE TO DO SO CAN CAUSE SERIOUS PERSONAL INJURY, DEATH, OR PROPERTY DAMAGE.

4. See Air Spring Cautions and Warnings in the Important Safety Notice Section of this publication prior to inflating or deflating the suspension system.
5. AIRTEK equipped vehicles — Deflate the air springs by disconnecting the height control valve linkage and lowering the height control valve linkage arm. This will exhaust the air pressure in the air springs.
6. Raise the frame.
7. Support the vehicle with frame stands.
8. Suspend the front axle with the shocks attached.
9. Remove the front wheels, hubs, brake shoes and backing plate assembly.
10. Disconnect the drag link from the steering arm.
11. SOFTEK equipped vehicles — proceed to step 13.
12. AIRTEK equipped vehicles — Remove lower air spring mounting fasteners for both air springs at the axle top pad and unseat from the top pad.
13. Support the axle with a floor jack.

WARNING

THE REPAIR OR RECONDITIONING OF SUSPENSION OR AXLE COMPONENTS IS NOT ALLOWED. HENDRICKSON ADVISES REPLACING ALL COMPONENTS FOUND TO BE DAMAGED OR OUT OF SPECIFICATIONS. ALL MAJOR HENDRICKSON COMPONENTS ARE HEAT TREATED AND TEMPERED. AIRTEK COMPONENTS CANNOT BE BENT, WELDED, HEATED, OR REPAIRED WITHOUT REDUCING THE STRENGTH OR LIFE OF THE COMPONENT. FAILURE TO FOLLOW THESE GUIDELINES CAN CAUSE LOSS OF VEHICLE CONTROL, AND POSSIBLE PERSONAL INJURY OR DEATH OR PROPERTY DAMAGE AND WILL VOID APPLICABLE WARRANTIES.

14. If the vehicle is equipped with the shock absorbers attached to the top axle wrap, it will be necessary to remove the lower shock mounting locknuts and washers. Remove the shock absorbers from the lower mounting bolts and push clear of spring assembly.

SERVICE HINT

If a clamp group nut fails to come off bolt, cut half way through the bolt with an abrasive cut off wheel, taking care not to contact axle beam or other components. Using an impact wrench, spin the locknut to fracture the bolt and remove.

15. Remove the 3/4" clamp group bolts, washers, and locknuts. Discard fasteners.
16. Lower the axle and remove from the vehicle.



AIRTEK®• SOFTEK® for Blue Bird Buses

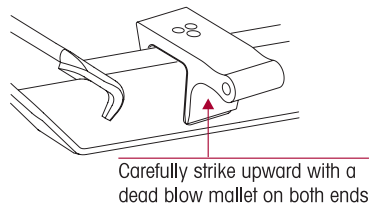
151

STEERTEK AXLE (Remove from Chassis)

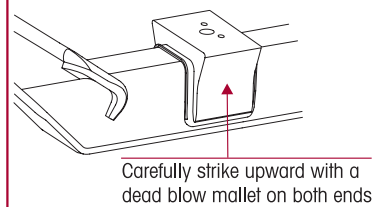
AXLE DISASSEMBLY

1. Remove the bottom axle wrap and liner from the axle.
2. Strike the top axle wrap with a dead blow mallet at the front and rear on the underside of the axle wrap to dislodge it from the axle. See Figure 9-42.

FIGURE 9-42
8K/10K



13.2K/14.6K



3. After removal of the top axle wrap from the axle inspect for cracks or fretting.
4. Remove the tie rod assembly. See Tie Rod disassembly in this section.

WARNING

REMOVAL OF THE CAP SCREWS WILL ALLOW THE STEERING KNUCKLE TO SEPARATE FROM THE AXLE. THE BACKBONE MUST BE SUPPORTED BEFORE REMOVAL OF THESE TWO (2) CAP SCREWS. FAILURE TO DO SO CAN CAUSE COMPONENT DAMAGE OR PERSONAL INJURY.

5. Remove the two $\frac{5}{8}$ " socket head cap screws from the steering knuckle assembly.
6. Remove the steering knuckle, thrust bearing, and shims (if equipped).
7. After complete removal of the one side, repeat steps 1-6 for the opposite side of the axle.
8. Inspect the steering kingpin bushings for excessive wear. If worn, replace the kingpin bushings and seals. See the Kingpin Bushing replacement instructions in this section.

AXLE PRE-ASSEMBLY

1. Install the new upper axle wrap liner on the axle. Index the liner with the axle's guide pin, see Figure 9-43.

CAUTION

DO NOT STRIKE THE TOP AXLE WRAP WITH A HAMMER. DAMAGE TO THE ALUMINUM AXLE WRAP WILL OCCUR. USE A PLASTIC DEAD BLOW Mallet WITH CARE WHEN INSTALLING THE AXLE WRAP.

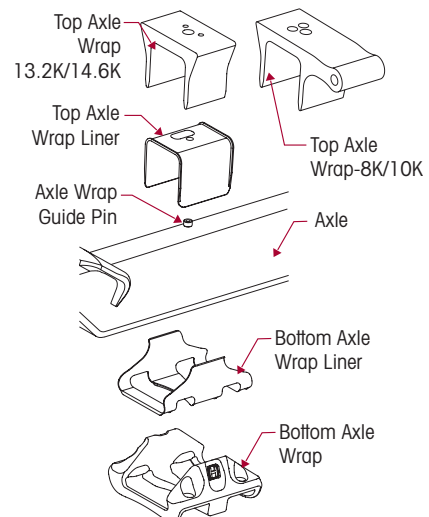
WARNING

SECURELY INSTALL THE TOP WRAP TO THE AXLE. FAILURE TO DO SO CAN CAUSE LOSS OF CONTROL OF THE VEHICLE, PERSONAL INJURY OR PROPERTY DAMAGE.

SERVICE HINT

Apply a lubricant (such as an aerosol silicone) to the outer surface of the plastic liner to aid in assembly of the top axle wrap.

FIGURE 9-43



AIRTEK® • SOFTEK® for Blue Bird Buses



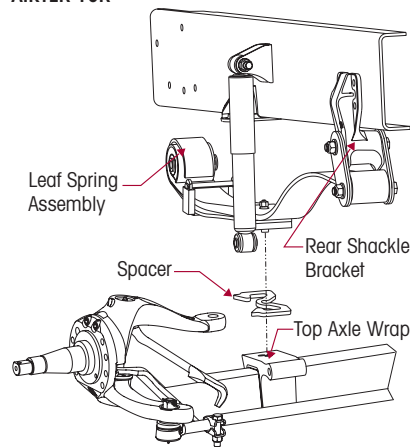
2. Install the top axle wrap, see Axle Wrap Assembly instructions located in this section. The axle wrap must be aligned with the guide pin on the axle.
3. At this point in the assembly, do not install anything further on the axle.

AXLE INSTALLATION

1. Place the new axle on the floor jack and position the axle under the vehicle.
2. Install the axle spacer (if equipped) on the top axle wrap prior to raising the axle into position.
3. Raise the axle into position, see Figure 9-44 and 9-45. Care must be taken at this point to ensure that the front leaf spring assemblies' center bolt is aligned correctly in the top axle wrap.

FIGURE 9-44

AIRTEK 10K



AIRTEK 14.6K

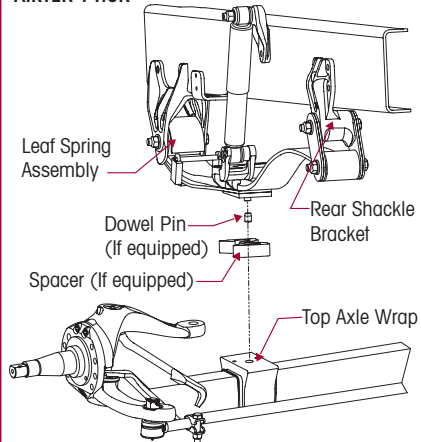
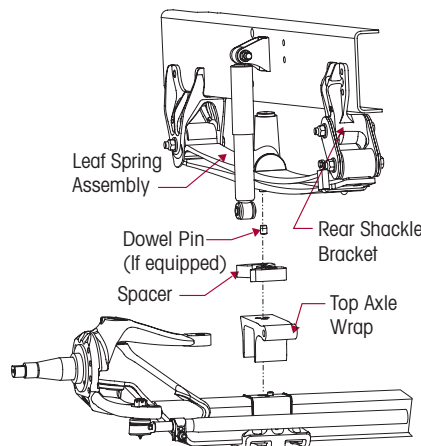
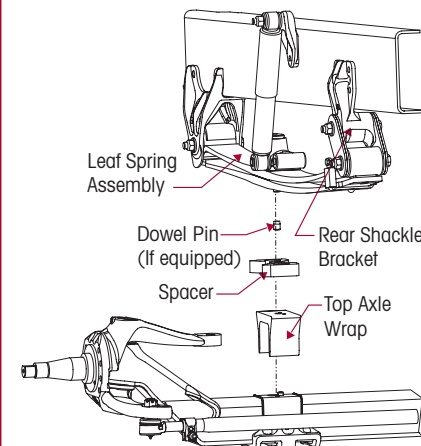


FIGURE 9-45

SOFTEK 8K/10K



SOFTEK 13.2K/14.6K

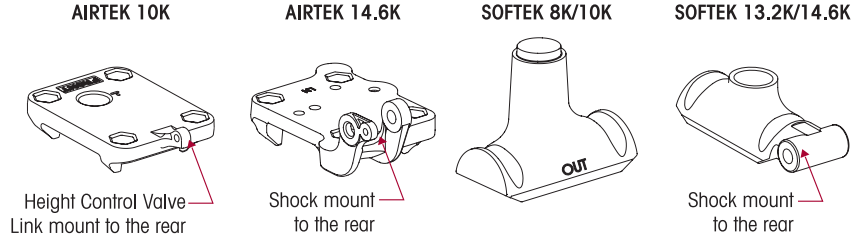




AIRTEK®• SOFTEK® for Blue Bird Buses

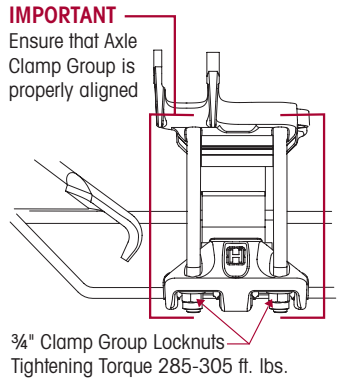
4. Verify that the galvanized liner is between the leaf springs and the top pad.
5. Install the new bottom axle wrap liners on the bottom axle wraps.
6. Install the bottom axle wraps on the axle.
7. Install the top pad with the directional identification facing correctly on the vehicle, see Figure 9-46.

FIGURE 9-46



8. Install the new 3/4" clamp group bolts, washers and locknuts. Snug the bolts, **DO NOT** tighten to the specified torque at this time.
9. Ensure that the clamp groups are properly aligned and the bolts are seated in the top pad, and the bottom axle wraps are centered on the top axle wraps. See Figure 9-47 and 9-48.

FIGURE 9-47 AIRTEK



IMPORTANT

Ensure that the 3/4" Clamp Bolts are seated properly in the Top Pad

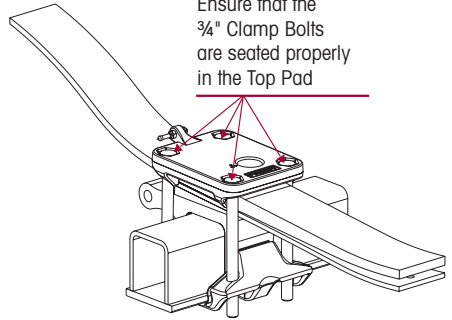
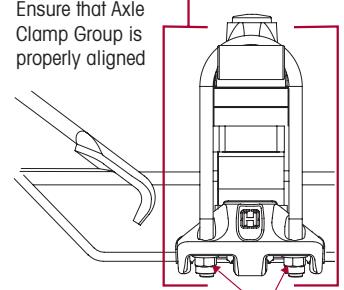


FIGURE 9-48 SOFTEK

IMPORTANT

Ensure that Axle Clamp Group is properly aligned



3/4" Clamp Group Locknuts
Tightening Torque 285-305 ft. lbs.

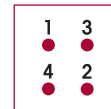
10. SOFTEK equipped vehicles — proceed to step 13.
11. See Air Spring Cautions and Warnings in the Important Safety Notice Section of this publication prior to inflating or deflating the suspension system.
12. AIRTEK equipped vehicles:
 - Engage the 10K air springs into the top pad. The bottom of the air spring snaps into the top pad.
 - Engage the 14.6K air springs into the top pad. Install new lower air spring mounting fasteners and tighten to 20-30 foot pounds torque.

AIRTEK® • SOFTEK® for Blue Bird Buses



13. Install the lower shock absorber connection (if removed). Install the lower shock fasteners and tighten to vehicle manufacturer's specifications.
14. Install the steering knuckles as per the Steering Knuckle replacement instructions in this section.
15. Install the tie rod assembly.
16. Install the 7/8" hardened washers on the Ackermann arm and the castle nuts. Tighten the castle nuts to 185 foot pounds, then rotate until the first castle slot lines up with the cotter pin bore in the tie rod end. Do not back off the nut for cotter pin installation.
17. Install the tie rod end cotter pins.
18. Connect the drag link. Install the castle nut. Tighten the castle nut to 185 foot pounds, then rotate until the first castle slot lines up with the cotter pin bore in the drag link. Do not back off the nut for cotter pin installation.
19. Install the drag link cotter pin.
20. Install the brake backing plate assemblies.
21. Install the brakes, hubs, and wheels as per manufacturer's guidelines.
22. Fill the hubs with the proper lubricant (see manufacturer's guidelines for recommended lubrication specifications).
23. Raise the vehicle and remove the frame stands.
24. Lower the vehicle.
25. SOFTEK equipped vehicles — proceed to step number 27.
26. AIRTEK equipped vehicles — Reconnect the height control valve and air up the system.
27. Tighten the 3/4" clamp group locknuts evenly in 50 foot pounds increments to 285-305 foot pounds torque in the proper sequence to achieve uniform bolt tension, see Figure 9-49.
28. SOFTEK equipped vehicles — proceed to step number 30.
29. AIRTEK equipped vehicles — Adjust ride height per instructions in the Alignment & Adjustments Section of this publication.
30. Grease the front steering components as per lubrication guidelines in the Preventive Maintenance Section of this publication.
31. Remove the wheel chocks.

FIGURE 9-49





STEERING KNUCKLE DISASSEMBLY

DISASSEMBLY

See tools needed to remove and install kingpin bushing under the Special Tools Section of this publication.

The steering knuckle disassembly and assembly includes the Kingpin Preparation and Measurement and Kingpin Bushing Removal process.

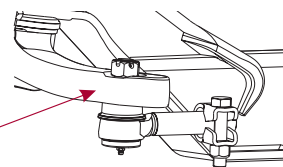
1. Place the vehicle on level floor.
2. Chock the wheels.
3. Raise the frame.
4. Support the vehicle with frame stands.
5. Remove the wheel and hub assembly.
6. Remove the brake components from steering knuckle.
7. Remove the tie rod assembly.

SERVICE HINT

Lightly tap the side of the Ackermann arm with a mallet to separate the tie rod end from the Ackermann arm, see Figure 9-50.

FIGURE 9-50

Lightly tap the side of Ackermann arm to loosen the tie end rod.



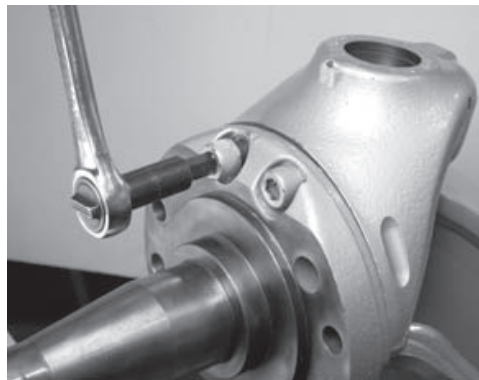
8. Remove the drag link from the knuckle if necessary.

WARNING

REMOVAL OF THE CAP SCREWS WILL ALLOW THE STEERING KNUCKLE TO SEPARATE FROM THE AXLE. THE STEERING KNUCKLE MUST BE SUPPORTED BEFORE REMOVAL OF THESE TWO (2) CAP SCREWS. FAILURE TO DO SO CAN CAUSE COMPONENT DAMAGE OR PERSONAL INJURY.

FIGURE 9-51

9. Remove the 2 socket head cap screws that connect upper kingpin connection to the steering knuckle, see Figure 9-51.
10. Remove the lower steering knuckle from the kingpin by sliding it down the kingpin.
11. Remove the upper steering knuckle by sliding it up off the kingpin.





KINGPIN PREPARATION AND MEASUREMENT

CLEANING GROUND AND POLISHED PARTS

- Use a cleaning solvent to clean ground or polished parts and surfaces. **DO NOT USE GASOLINE.**
- Do not clean ground or polished parts in a hot solution tank or with water, steam, or alkaline solutions. These solutions will cause corrosion of the parts.

DRYING THE CLEANED PARTS

- Parts must be dried immediately after cleaning. Dry the parts with clean paper towels, clean rags, or compressed air. Do not dry bearings by spinning with compressed air. Damage to the bearings will result.

PREVENTING CORROSION ON CLEANED PARTS

- Apply a light coating of oil to all cleaned and dried parts that are going to be reused. Do not apply oil to the brake lining or the brake drums. If parts are to be stored, apply an effective rust inhibitor to all surfaces.

WARNING

TO HELP PREVENT SERIOUS EYE INJURY, ALWAYS WEAR PROPER EYE PROTECTION WHEN YOU PERFORM VEHICLE MAINTENANCE OR SERVICE.

WARNING

SOLVENT CLEANERS CAN BE FLAMMABLE, POISONOUS AND CAUSE BURNS. TO HELP AVOID SERIOUS PERSONAL INJURY, CAREFULLY FOLLOW THE MANUFACTURER'S PRODUCT INSTRUCTIONS AND GUIDELINES AND THE FOLLOWING PROCEDURES:

- WEAR PROPER EYE PROTECTION.
- WEAR CLOTHING THAT PROTECTS YOUR SKIN.
- WORK IN A WELL VENTILATED AREA.
- DO NOT USE GASOLINE, SOLVENTS OR OTHER MATERIALS THAT CONTAIN GASOLINE THAT CAN EXPLODE.
- HOT SOLUTION TANKS OR ALKALINE SOLUTIONS MUST BE USED CORRECTLY. FOLLOW THE MANUFACTURER'S RECOMMENDED INSTRUCTIONS AND GUIDELINES CAREFULLY TO HELP PREVENT PERSONAL ACCIDENT OR INJURY.

CAUTION

DO NOT USE HOT SOLUTION TANKS OR WATER AND ALKALINE SOLUTIONS TO CLEAN GROUND OR POLISHED PARTS. DAMAGE TO THE PARTS WILL RESULT.

WARNING

THE STEERTEK HAS A UNIQUE AXLE. THE KINGPIN IS CRYOGENICALLY INSTALLED IN THE AXLE. THE KINGPIN IS A NON-REPLACEABLE COMPONENT OF THE AXLE ASSEMBLY. DO NOT TRY TO REMOVE THE KINGPIN. DOING SO WILL DAMAGE THE AXLE AND MAY CAUSE LOSS OF VEHICLE CONTROL, PERSONAL INJURY OR PROPERTY DAMAGE. IF THE KINGPIN SHOWS SIGNS OF MOVEMENT, CONTACT HENDRICKSON PRODUCT ENGINEERING - TECH SERVICES.

1. Prepare and polish the kingpin by removing all grease and excess debris using a fine grit (220 grit or higher) emery cloth and parts solvent, see Figures 9-52 through 9-55.



AIRTEK®• SOFTEK® for Blue Bird Buses

FIGURE 9-52



FIGURE 9-53



FIGURE 9-54 KINGPIN BEFORE CLEANING



FIGURE 9-55 KINGPIN AFTER CLEANING



2. Inspect the kingpin for wear or damage. Use a micrometer and measure the upper and lower kingpin in two locations. Positions must be 90° opposed from each other. If the kingpin has less than 1.802" diameter, replacement of the axle is necessary, see Figures 9-56 through 9-59.

Kingpin minimum dimension is 1.802"

FIGURE 9-56



FIGURE 9-57



FIGURE 9-58



FIGURE 9-59





KINGPIN BUSHING REMOVAL

1. Remove the retaining ring for the grease cap.
2. A hydraulic shop press with a minimum forcing capacity of 2.5 tons (or use an arbor press) will be required.

⚠ WARNING

BEFORE APPLYING HYDRAULIC PRESSURE TO ANY TOOLING SET-UP, ALWAYS CHECK TO BE SURE THE PRESS PLATE, ADAPTERS, AND COMPONENTS BEING WORKED ON ARE POSITIONED PROPERLY, I.E. "IN LINE" WITH THE RAM. IMPROPER POSITIONING CAN CAUSE PERSONAL INJURY OR COMPONENT DAMAGE.

⚠ CAUTION

BEFORE APPLYING HYDRAULIC PRESSURE TO REMOVE OR INSTALL THE KINGPIN BUSHING, SUPPORT THE LOWER STEERING KNUCKLE AS SHOWN IN FIGURES 9-60 AND 9-61. IMPROPER SUPPORT TO THE STEERING KNUCKLES CAN CAUSE COMPONENT DAMAGE.

3. Use the grease cap to press out the kingpin bushing and seal. Remove the grease zerk in the grease cap or use a hollow driver, (see Figure 9-60) to press out the kingpin bushing.
4. Install the lower steering knuckle upside down in press. Be sure to support the lower steering knuckle assembly so that it sits in-line with the press, see Figure 9-61.
5. Use the same procedure to remove the kingpin bushing in the upper kingpin connection or the steering arm, see Figures 9-60 through 9-62.
6. Clean the parts and inspect for reassembly, see Figure 9-63.

FIGURE 9-60



FIGURE 9-61

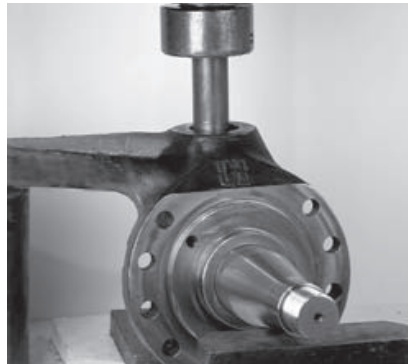


FIGURE 9-62



FIGURE 9-63





STEERING KNUCKLE BORE MEASUREMENT

Complete the following steering knuckle bore inspection and the measurement instructions prior to installing the kingpin bushing.

1. Measure the upper knuckle bore inside diameter at two locations. Always use an inside micrometer or a telescoping gauge when taking a knuckle bore measurement. Some out-of-roundness at the top and bottom of the bore edges is acceptable. Steering knuckle bore diameter is $1.938" \pm 0.003"$
2. Measure the upper and lower bore in two positions and at two locations. The two positions must be 90° opposed from each other, see Figures 9-64 through 9-66. If the average measurement is more than the knuckle bore maximum diameter specification, replace the knuckle.

FIGURE 9-64



FIGURE 9-65



FIGURE 9-66



KINGPIN BUSHING INSTALLATION

1. A hydraulic shop press with a minimum forcing capacity of 5 tons will be required.

WARNING

BEFORE APPLYING HYDRAULIC PRESSURE TO ANY TOOLING SET-UP, ALWAYS CHECK TO BE SURE THE PRESS PLATE, ADAPTERS, AND COMPONENTS BEING WORKED ON ARE POSITIONED PROPERLY, I.E. "IN LINE" WITH THE RAM. IMPROPER POSITIONING CAN CAUSE PERSONAL INJURY OR COMPONENT DAMAGE.

2. Install the lower or upper steering knuckle in the press.
3. Install the kingpin bushing from the machined side (axle side) of the lower steering knuckle using a bushing driver, (see driver specifications in the Special Tools Section of this publication). Press in bushing to a depth of no less than $1\frac{5}{64}"$ (0.236") or 6 millimeters and no more than $\frac{5}{16}"$ (0.32") or 8 millimeters, see Figures 9-67 and 9-69.
4. Following this procedure it is necessary to ream the kingpin bushings to fit the kingpins, (see Kingpin Bushing Reaming Instructions).

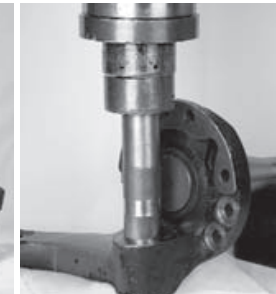
FIGURE 9-67



FIGURE 9-68



FIGURE 9-69





KINGPIN BUSHING REAMING

CAUTION

REAM THE KINGPIN BUSHINGS WITH AN ADJUSTABLE STRAIGHT FLUTE REAMER. (SEE SPECIAL TOOLS SECTION OF THIS PUBLICATION) DO NOT HONE OR BURNISH THE KINGPIN BUSHINGS. HONING OR BURNISHING WILL DAMAGE THE BUSHINGS AND VOID WARRANTY.

WARNING

WHEN INSTALLING STEERING KNUCKLE COMPONENTS IN A VISE IT IS NECESSARY TO PROTECT THE MACHINED SURFACES FROM GOUGES OR MARRING BY USING BRASS JAWS. FAILURE TO DO SO CAN CAUSE PREMATURE PART DAMAGE, DAMAGE TO THE STEERING KNUCKLE COMPONENTS, LOSS OF WARRANTY, LOSS OF VEHICLE CONTROL, CAUSING PERSONAL INJURY OR PROPERTY DAMAGE.

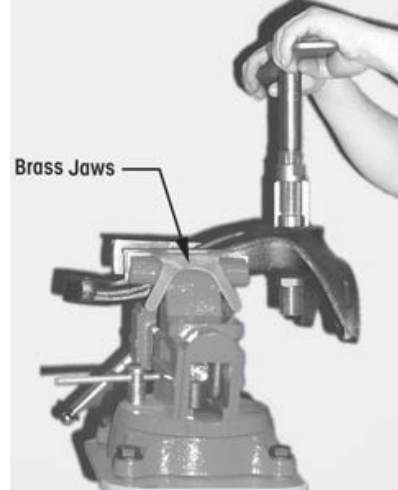
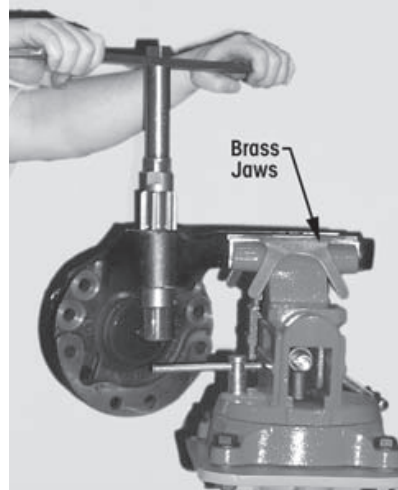
1. Install the lower steering knuckle assembly in a vise with brass jaws.

SERVICE HINT

It is acceptable to mount the knuckle components in a vise either vertically or horizontally when performing the reaming procedure.

2. Install the reamer into the lower steering knuckle until the blades touch the kingpin bushing.
3. Rotate the reamer with light downward pressure. Rotate the reamer smoothly. Do not apply too much pressure, see Figures 9-70 and 9-71.

FIGURE 9-70 LOWER STEERING KNUCKLE IN VISE **FIGURE 9-71** UPPER STEERING KNUCKLE IN VISE



4. Slide the reamer out of the bottom of the steering knuckle assembly. If it is necessary to remove the reamer from the top, rotate the reamer opposite of cutting rotation.
5. Clean and remove all kingpin bushing material from the steering knuckle assembly. Take special attention to remove material from the grease channels and dimples.
6. Clean the 5/8" brake backing plate bolts with a wire wheel and run a tap through the threads of the lower steering knuckle assembly and then flush out with brake cleaner and dry with compressed air.

WARNING

PRIOR TO INSTALLATION ENSURE THAT ALL RESIDUAL LOCTITE® MATERIAL IS REMOVED FROM THE MOUNTING BOLTS AND THE THREAD BORES IN THE UPPER STEERING KNUCKLES, AND NEW LOCTITE 277 OR EQUIVALENT IS APPLIED TO HELP ENSURE THAT THE BOLTS SUSTAIN THE PROPER TORQUE REQUIREMENT. FAILURE TO DO SO CAN CAUSE LOSS OF VEHICLE CONTROL RESULTING IN PERSONAL INJURY OR PROPERTY DAMAGE.



AIRTEK®• SOFTEK® for Blue Bird Buses

NOTE

The Hendrickson Genuine part, socket head cap screw comes with a pre-applied loctite compound.

7. Install the upper and lower steering knuckle on the kingpin.
8. Check for the proper fit by rotating the knuckle assembly back and forth to verify there is no binding on the kingpin, see Figures 9-72 and 9-73.
9. If the bushing is too tight repeat steps 1 through 8 until the proper clearance is achieved.

NOTE

Bushing size is to be 0.001" larger than the kingpin size.

FIGURE 9-72

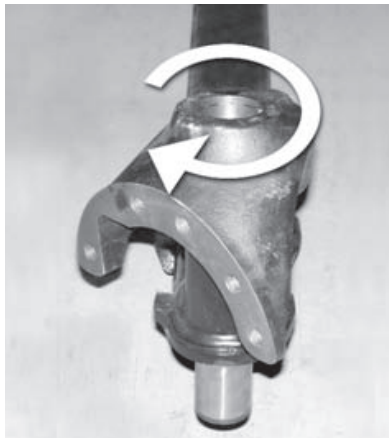


FIGURE 9-73



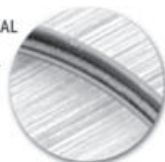
KINGPIN SEAL INSTALLATION

1. Place the steering knuckle assembly in a vise with brass jaws or place on a suitable workbench. The steering knuckle will have the machined surface facing up (axle side up).
2. Lay the kingpin seal into the bore of the steering knuckle. The seal lip should face outward or toward the axle.
3. Use a bushing driver tool and press seal firmly into the steering knuckle assembly.
4. Install the kingpin seal until it makes contact with the kingpin bushing, see Figures 9-74 and 9-75.

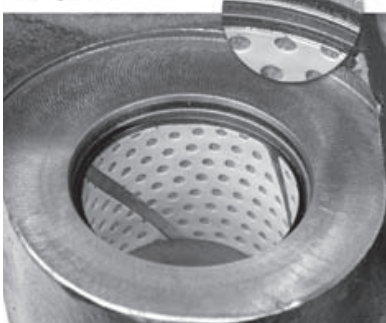
FIGURES 9-74 AND 9-75

MAGNIFICATION OF LIP SEAL

Lip seal faces toward axle.



Magnification of King Pin Bushing and Lip seal installed in steering knuckle.





STEERING KNUCKLE ASSEMBLY

ASSEMBLY

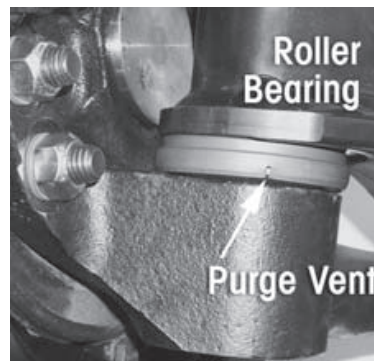
After replacement of the kingpin bushings it is necessary to re-assemble the steering knuckle assemblies. The STEERTEK axle is equipped with two different thrust bearings installed. The composite thrust bearing is installed on the left side of the axle. The roller bearing is installed on the right side of the axle, see Figures 9-76 and 9-77. Do not substitute after-market components when servicing.

1. Install the thrust bearing on the lower kingpin with the seal facing up toward axle (the black seal will designate the top side). The composite thrust bearing is installed on the left side of the axle. The roller bearing is installed on the right side of the axle, see Figures 9-76 and 9-77.
2. Install the shim on the upper kingpin.
3. Pack the bushing dimples on the upper and lower steering knuckles with multi purpose Lithium based grease (NLGI Grade 2) before installation, see Figure 9-76 and 9-77.

FIGURE 9-76



FIGURE 9-77



4. Install the upper steering knuckle on the upper arm kingpin.
5. Install the lower steering knuckle on the lower kingpin and install the old socket head cap screws loose into the top two threaded holes.

SERVICE HINT

The easiest way to achieve this is with the grease caps not installed in the knuckle assemblies. This eliminates back pressure. The assembly can then freely slide up and down on the kingpin. If the grease caps are still installed, remove the grease zerks to avoid creating back pressure. Grease zerks will be re-installed at the end of the procedure.

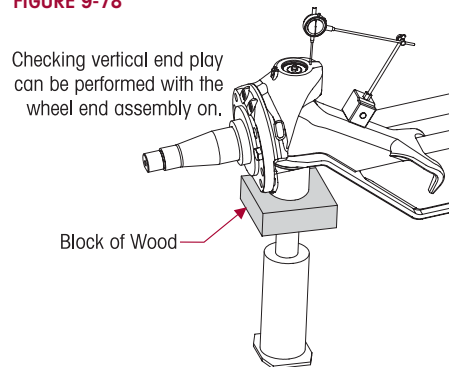
6. Install a bottle jack under the lower knuckle and slightly raise the knuckle until it is possible to thread in the (3) brake backing plate bolts by hand. These are for guide purposes only.
7. Snug the two socket head cap screws.
8. Lower the bottle jack so that all the vertical clearance is on the underside of the axle.
9. Affix a magnetic base dial indicator on the axle and place the tip of the dial indicator on top of the knuckle assembly, see Figure 9-78.
10. Zero the dial indicator.



AIRTEK®• SOFTEK® for Blue Bird Buses

11. Raise the bottle jack until there is no clearance between the knuckle assembly and the bottom of the axle, slightly lifting the axle.
12. Check the reading on the dial indicator. The specification for vertical travel on the steering knuckle during assembly is 0.008" to 0.011".
13. If the clearance is above 0.011", loosen the socket head cap screws and push down on the knuckle assembly until the proper vertical clearance is achieved. Add (0.005") shim if necessary.
14. If the clearance is below the 0.008", loosen the two socket head cap screws and pull up on the knuckle assembly until the proper vertical clearance is achieved. If the 0.008" minimum clearance is unattainable it may be necessary to remove a 0.005" shim.

FIGURE 9-78

**NOTE**

The Hendrickson Genuine part, socket head cap screw comes with a pre-applied loctite compound.

WARNING

PRIOR TO INSTALLATION ENSURE THAT ALL RESIDUAL LOCTITE MATERIAL IS REMOVED FROM THE MOUNTING BOLTS AND THE THREAD BORES IN THE UPPER STEERING KNUCKLE, AND NEW LOCTITE 277 OR EQUIVALENT IS APPLIED TO HELP ENSURE THAT THE BOLTS SUSTAIN THE PROPER TORQUE REQUIREMENT. FAILURE TO DO SO CAN CAUSE LOSS OF VEHICLE CONTROL RESULTING IN PERSONAL INJURY OR PROPERTY DAMAGE.

15. Remove one old socket head cap screw and replace with new socket head cap screw.
16. Remove second socket head cap screw and replace with new socket head cap screw. Tighten both socket head cap screws to 175-200 foot pounds torque.
17. Recheck the vertical clearance with the dial indicator or a 0.010" feeler gauge, see Figure 9-78.
18. Remove the brake spider bolts, they should thread out freely.
19. Remove the bottle jack and continue assembling the wheel ends.

IMPORTANT NOTE

Loctite applied to the three brake spider bolts is a critical procedure to ensure that these bolts sustain the torque requirement of Steering knuckle assembly.

20. Apply loctite to the three brake spider bolts prior to installation into the brake spider. Tighten bolts to 175-200 foot pounds torque.

WARNING

DO NOT GREASE KNUCKLES WITHOUT THE BRAKE SPIDER INSTALLED AND TIGHTENED TO PROPER TORQUE. FAILURE TO DO SO CAN CAUSE COMPONENT DAMAGE RESULTING IN FAILURE AND LOSS OF VEHICLE CONTROL, POSSIBLY CAUSING PERSONAL INJURY OR PROPERTY DAMAGE.

21. Install the tie rod end into the lower steering knuckle arm.
22. Tighten the castle nuts to 185 foot pounds torque then rotate the castle nut to the next castle slot and install cotter pin.
23. Install the drag link into the steering arm and tighten to the vehicle manufacturer's specifications.

AIRTEK® • SOFTEK® for Blue Bird Buses



24. Install new o-rings on the grease caps and lubricate o-rings with grease.
25. Install grease caps and new retaining rings.
26. Install brakes, drums, wheels and tires.
27. Remove jack and safety stands.
28. Grease steering knuckles with the vehicle on the floor.
29. Remove wheel chocks.

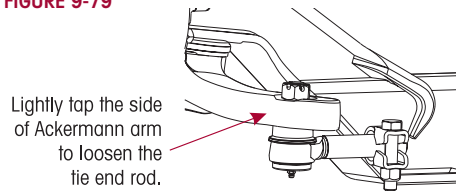
TIE ROD END AND CROSS TUBE

NOTE: Hendrickson supplies different tie rod configurations. Prior to ordering find the part number on the tie rod tube. For additional information see Technical Bulletin SEU-0223 or contact Hendrickson Sales Engineering.

DISASSEMBLY

1. Chock the wheels.
2. Position the steer axle tires straight ahead.
3. Remove the cotter pin and castle nut.
4. Lightly tap the side of the Ackermann arm to loosen the tie rod end from the Ackermann arm, see Figure 9-79.
5. Repeat to steps 3 and 4 to remove the other tie rod end.
6. Remove the cross tube and tie rod ends from the vehicle.
7. Mount the cross tube in a soft jaw vice.
8. Remove the hardware from the clamp on the cross tube.
9. Count the exposed threads on the tie rod end being replaced.
10. Remove the tie rod end from the cross tube.

FIGURE 9-79



WARNING

DO NOT HEAT THE CROSS TUBE WITH A TORCH TO FACILITATE THE REMOVAL OF THE TIE ROD END. THE USE OF SUCH HEAT CAN ADVERSELY AFFECT THE STRENGTH OF THE CROSS TUBE. A COMPONENT DAMAGED IN THIS MANNER WILL RESULT IN LOSS OF WARRANTY, AND CAN RESULT IN THE AND LOSS OF VEHICLE CONTROL, AND POSSIBLE PERSONAL INJURY OR PROPERTY DAMAGE.

11. If the opposing tie rod end is being replaced repeat steps 8 through 10.
12. Inspect the cross tube for dents, cracks, or thread damage. Replace the cross tube if needed.



AIRTEK®• SOFTEK® for Blue Bird Buses

ASSEMBLY

1. Lubricate the new tie rod end threads with Anti-Seize.

NOTE

When installing the cross tube the thread direction of the tie rod ends are as follows:

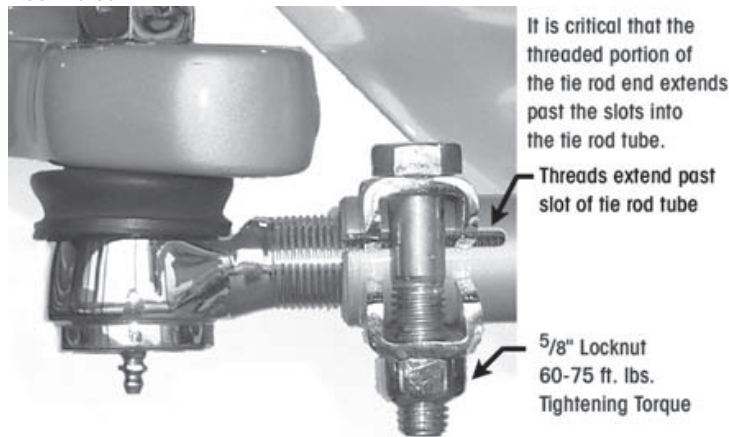
- A right hand threaded tie rod end will be installed into the right side Ackermann arm.
- A left hand threaded tie rod end will be installed into the left side Ackermann arm.

2. Install the new tie rod end into the cross tube, leaving the same amount of threads exposed that were counted on the failed tie rod end prior to removal.

WARNING

THE THREADED PORTION OF THE TIE ROD END MUST EXTEND PAST THE SLOTS INTO THE TIE ROD CROSS TUBE, SEE FIGURE 9-80. FAILURE TO DO SO CAN CAUSE COMPONENT DAMAGE, LOSS OF VEHICLE CONTROL AND POSSIBLE PERSONAL INJURY OR PROPERTY DAMAGE.


FIGURE 9-80



3. Replace the opposing tie rod end if necessary by repeating steps 2 and 3.
4. If replacing opposing tie rod end, it is critical that the cross tube will rotate in the opposing tie rod end.

WARNING

DO NOT HEAT THE CROSS TUBE WITH A TORCH TO ROTATE THE CROSS TUBE IN THE TIE ROD END. THE USE OF SUCH HEAT CAN ADVERSELY AFFECT THE STRENGTH OF THE CROSS TUBE. A COMPONENT DAMAGED IN THIS MANNER WILL RESULT IN LOSS OF WARRANTY, AND CAN RESULT IN THE LOSS OF VEHICLE CONTROL, AND POSSIBLE LOWER STEERING KNUCKLE PERSONAL INJURY OR PROPERTY DAMAGE.

5. Install the cross tube into the Ackermann arms.
6. Tighten the castle nuts to  185 foot pounds torque then rotate the castle nut to the next castle slot and install cotter pin.
7. Grease tie rod ends, see Lubrication Chart for required lubricant in the Preventive Maintenance Section of this publication.
8. Set the toe, (see the Toe Adjustment Procedure in the Alignment & Adjustments Section of this publication).
9. Remove the wheel chocks.

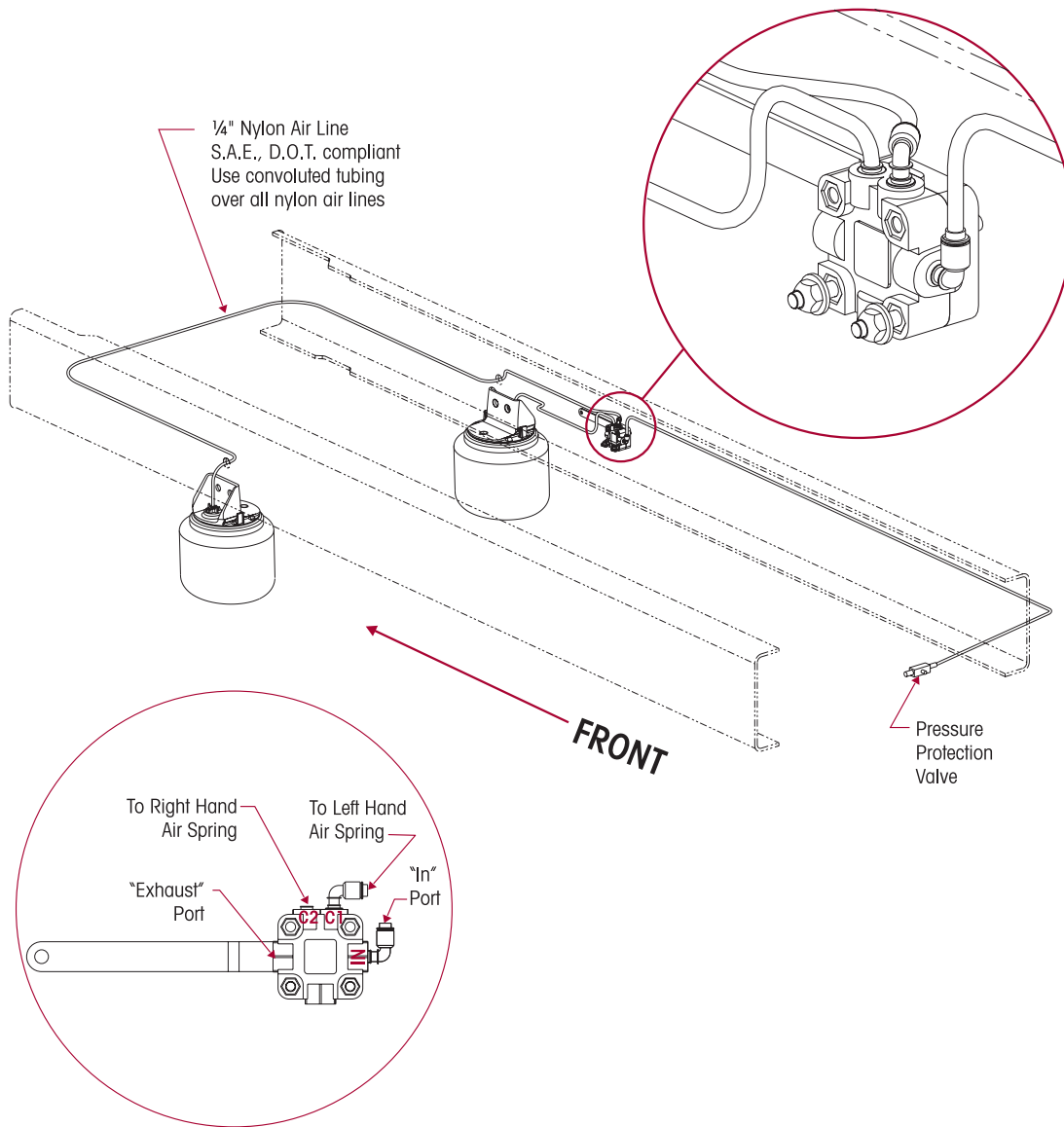


**SECTION 10
Plumbing Diagrams**

166

AIRTEK SINGLE HEIGHT CONTROL VALVE – 10K

When replacing or installing nylon air line tubing into quick-connect fittings it is critical that the end of the air line is cut square. Improper cut of the end of the air line tubing can cause the air line to seat improperly in the quick connect fitting causing air leakage.

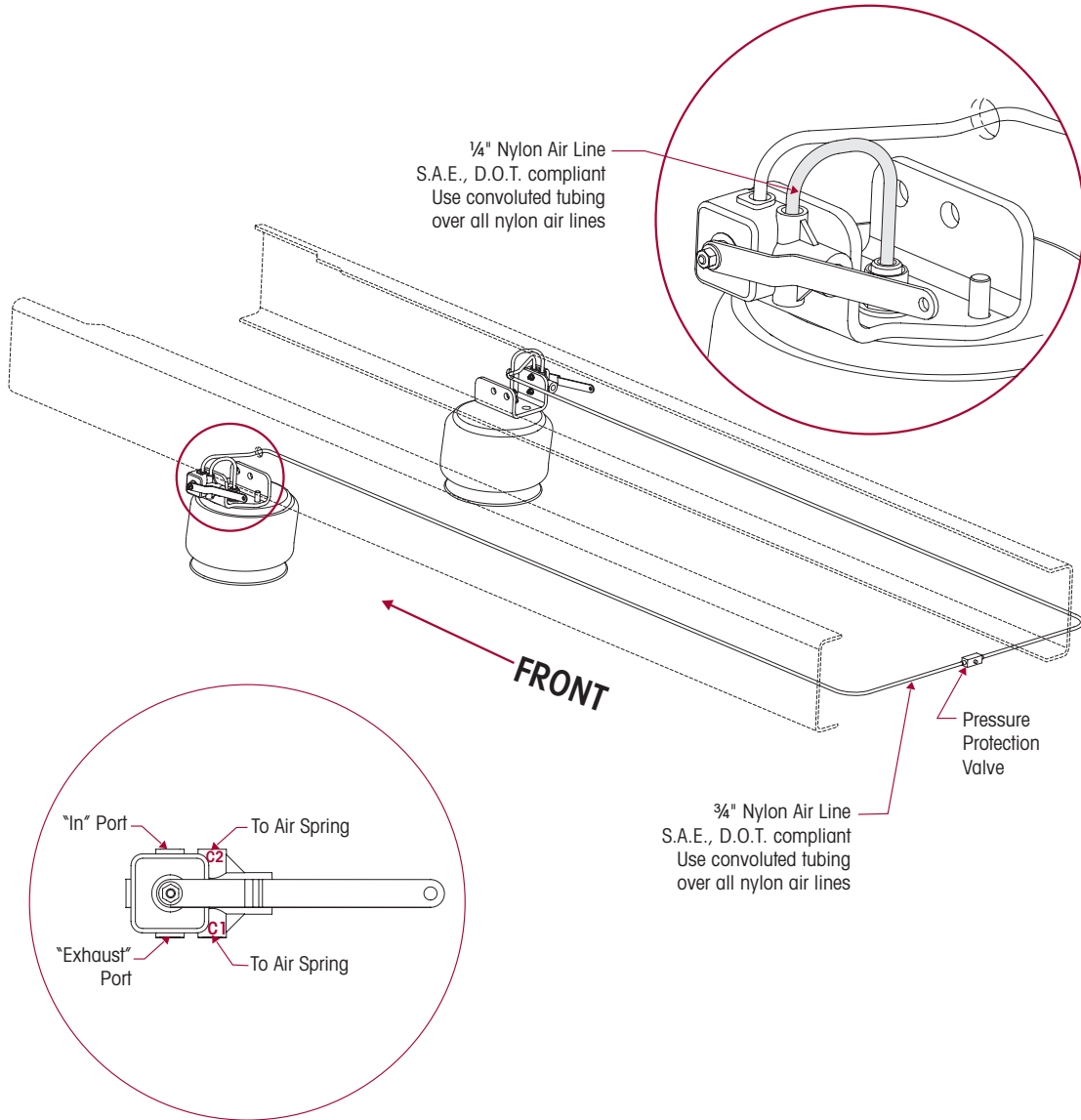




AIRTEK®• SOFTEK® for Blue Bird Buses

AIRTEK DUAL HEIGHT CONTROL VALVES – 14.6K

When replacing or installing nylon air line tubing into quick-connect fittings it is critical that the end of the air line is cut square. Improper cut of the end of the air line tubing can cause the air line to seat improperly in the quick connect fitting causing air leakage.



AIRTEK/SOFTEK

TROUBLE SHOOTING GUIDE

CONDITION	POSSIBLE CAUSE	CORRECTION
Worn or damaged kingpins and kingpin bushings	Dirt in system- contaminated lubricant	Polish and inspect kingpin, replace bushing and seals, then follow specified lubrication procedures
	Incorrect lubricant	Lubricate axle with specified lubricant
	Axle not lubricated at scheduled frequency	Lubricant axle at scheduled frequency
	Incorrect lubrication procedures	Use correct lubrication procedures
	Lubrication interval not compatible with operating conditions	Change lubrication interval to match operating conditions
Vibration or shimmy of front axle during operation	Worn or missing seals	Replace worn or missing seals
	Caster out of specification	Check ride height prior and adjust caster to specification
	Wheels and/or tires out of balance	Balance or replace wheels and/or tires
	Worn shock absorbers	Replace shock absorbers
	Worn thrust washers (if equipped) and rear hanger clamps	Replace thrust washers (if equipped) and rear hanger clamps
Excessive wear on tires or uneven tire tread wear	Broken engine mount	Replace engine mount
	Wheel bearing adjustment	Adjust wheel bearing to the vehicle manufacturers specifications.
	Tires have incorrect air pressure	Adjust tire pressure to manufacturer's specification.
	Tires out of balance	Balance or replace tires
	Incorrect tandem axle alignment	Align tandem axles
	Incorrect toe setting	Adjust toe-in to manufacturer's specification
	Incorrect steering arm geometry	Repair steering system as necessary
	Worn kingpin bushings	Replace kingpin bushings
Vehicle is hard to steer	Excessive wheel bearing end play	Check specified wheel nut torque, replace worn or damaged wheel bearings
	Wheel bearing adjustment	Adjust wheel bearing to the vehicle manufacturers specifications.
	Low pressure in the power steering system	Repair power steering system
	Steering linkage needs lubrication	Lubricate steering linkage
	Steering knuckles are binding	Check vertical clearance
	Incorrect steering ar geometry	Repair steering system as necessary
	Caster out of specification	Check ride height prior and adjust caster to specification
	Tie rod ends hard to move	Replace tie rod ends
Worn thrust bearing	Replace thrust bearing	
Steering gear box internal problem	Perform steering gear trouble shooting procedures per steering gear manufacturing guidelines.	



AIRTEK/SOFTEK

TROUBLE SHOOTING GUIDE (CONTINUED)

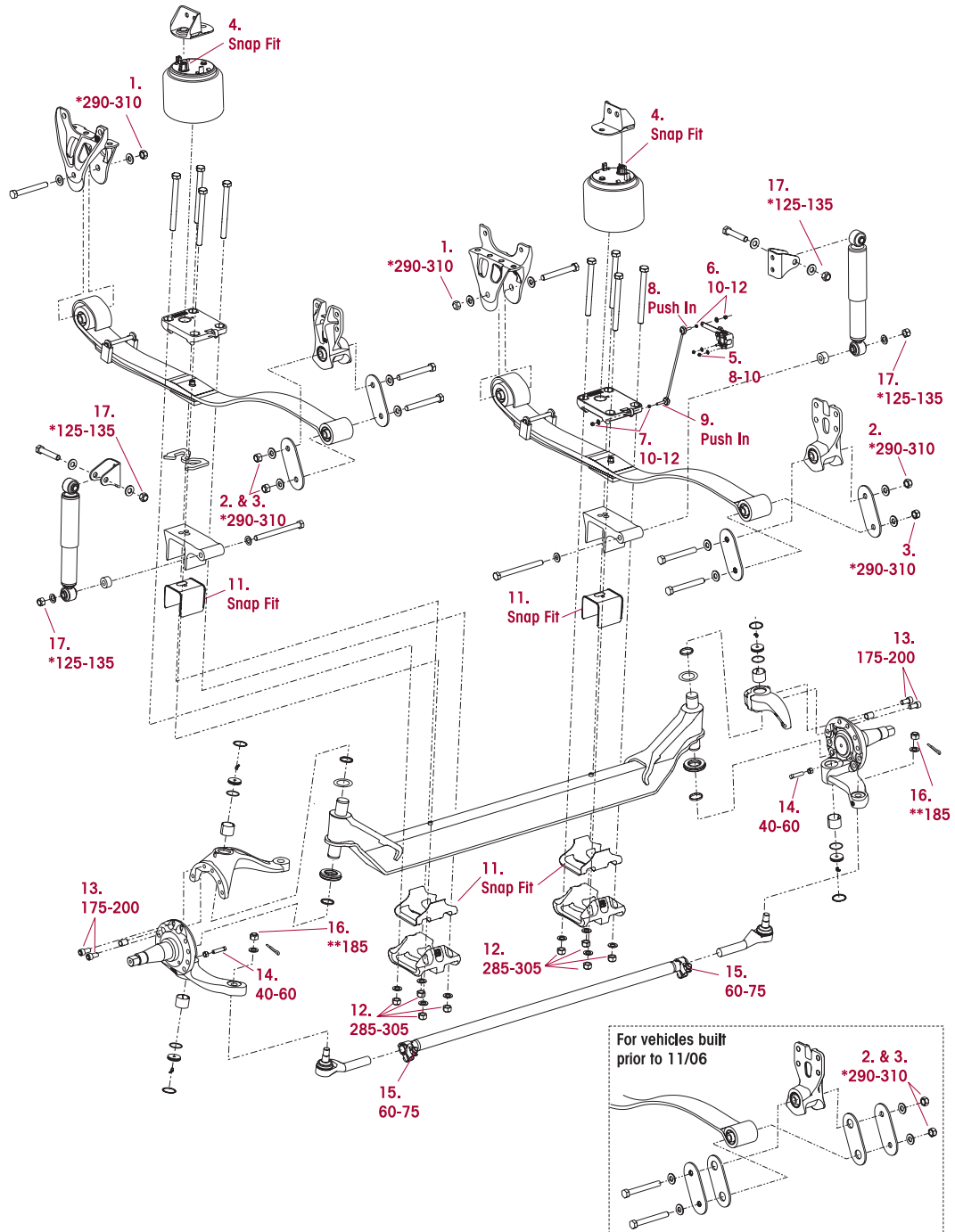
CONDITION	POSSIBLE CAUSE	CORRECTION
Tie rod ends are worn and require replacement	Tie rod ends need lubrication	Lubricate tie rod end. Make sure lubrication schedule is followed.
	Severe operating conditions	Increase frequency of inspection and lubrication intervals
	Damaged boot on tie rod end	Replace tie rod end
Bent or broken cross tube, tie rod end ball stud or tie rod end NOTE: Damaged components require replacement	Pump/gear relief valve pressure setting exceeds system specifications	Adjust power steering system to manufacturer's specified pressure
	Steering gear poppets improperly set or malfunctioning	Check for proper operation or adjust poppets to OEM specifications
	Axle stops improperly set	Set axle stops to OEM specifications
	Severe duty cycle service	Increase frequency of inspection and lubrication intervals
Worn or broken steering ball stud	Drag link fasteners lightened past specified torque	Tighten drag link fasteners to the specified torque
	Lack of lubrication or incorrect lubricant	Lubricate linkage with specified lubricant
	Power steering stops out of adjustment	Adjust steering stops to OEM specifications
Suspension has harsh or bumpy ride	Air spring not inflated	Check air supply to air spring, repair as necessary
	Air spring ride height out of specification	Adjust ride height to proper specification
	Broken or worn leaf spring	Replace leaf spring
	Front suspension overloaded	Redistribute steer axle load
Restricted steering radius	Steering stops not adjusted correctly	Adjust steering stops to achieve correct wheel cut
Vehicle leans	Ride height incorrect	Adjust ride height to specification
	Air spring(s) are not inflated	Repair source of air pressure loss
	Suspension is not torqued correctly at installation	Perform AIRTEK spring hanger retorque procedure. See Tightening Torque Specification Section of this publication
	Leaf spring broken	Replace leaf spring
	Excessive weight bias	Contact the vehicle manufacturer or Hendrickson Tech Services
Vehicle wanders	Caster out of specifications	Check ride height prior and adjust caster to specification
	Incorrect toe setting	Adjust toe to specification
	Fifth wheel not greased	Grease fifth wheel
	Air in the power steering system	Remove air from the power steering systems
	Rear ride height out of adjustment	Adjust ride height to specification
	Front ride height out of adjustment	Adjust ride height to specification





Hendrickson Recommended
Torque Values Provided In Foot Pounds

Blue Bird Vision Buses - 10K Capacity





AIRTEK for Blue Bird Vision Buses – 10K

HENDRICKSON RECOMMENDED TORQUE SPECIFICATIONS				
NO.	COMPONENT	QTY.	SIZE	TORQUE FT./LBS.
1	Front Frame Hanger to Front Leaf Spring Eye	2	M20	*290-310
2	Rear Shackle Bracket to Shackle Plate	2	M20	*290-310
3	Rear Shackle Bracket to Spring Eye	2	M20	*290-310
4	Air Spring	2	Self-Locking	Snap Fit
5	Height Control Valve to Frame	2	¼"	8-10
6	HCV Linkage to HCV Arm	2	⅝"	10-12
7	HCV Linkage to Top Pad	2	⅝"	10-12
8	HCV Linkage Grommet to HCV Arm	1	Grommet	Push In
9	HCV Linkage Grommet to Top Pad	1	Grommet	Push In
10	Spring Center Aligning Dowel Pin (Flat Floor Bus)	2	¾"	***Loose Fit
11	Axle Wrap Liners for Clamp Group	2	Formed	Snap Fit
WARNING: DO NOT ASSEMBLE CLAMP GROUP WITHOUT AXLE WRAP LINERS. FAILURE TO DO SO CAN CAUSE LOSS OF VEHICLE CONTROL, PROPERTY DAMAGE OR PERSONAL INJURY.				
12	Clamp Group Hardware	8	¾"	285-305
WARNING: ENSURE CLAMP GROUP IS ALIGNED PROPERLY PRIOR TO TIGHTENING HARDWARE. FAILURE TO DO SO CAN CAUSE LOSS OF VEHICLE CONTROL, PROPERTY DAMAGE OR PERSONAL INJURY.				
13	Knuckle Attachment Bolt (Socket Head Cap Screw)	4	⅝"	175-200
14	Knuckle / Axle Wheel Stop Bolt	2	⅝" Jam Nut	40-60
15	Tie Rod Tube to Tie Rod Ends	2	⅝"	60-75
16	Tie Rod Ends to Lower Steering Knuckle	2	7/8" Castle Nut	**185
17	Shocks Eye Bolts	2	¾"	*125-135
<ul style="list-style-type: none"> • All hardware ¼" and greater is Grade 8 with no additional lubrication. Frame mount hardware in most cases are Huck style fasteners supplied by the OEM. 				
NOTE: * All hardware information in gray in the matrix denotes recommended torques for fasteners originally supplied by the vehicle manufacturer. If Hendrickson supplied fasteners are used, tighten to Hendrickson torque values, if non Hendrickson fasteners are used, follow torque specifications listed in the vehicle manufacturer's service manual. Hendrickson is not responsible for maintaining vehicle manufacturer's torque values. ** Torque to 185 foot lbs., advance nut to next hex face to install cotter pin. Do not back off nut for cotter pin installation. *** Denote items not shown on illustration.				

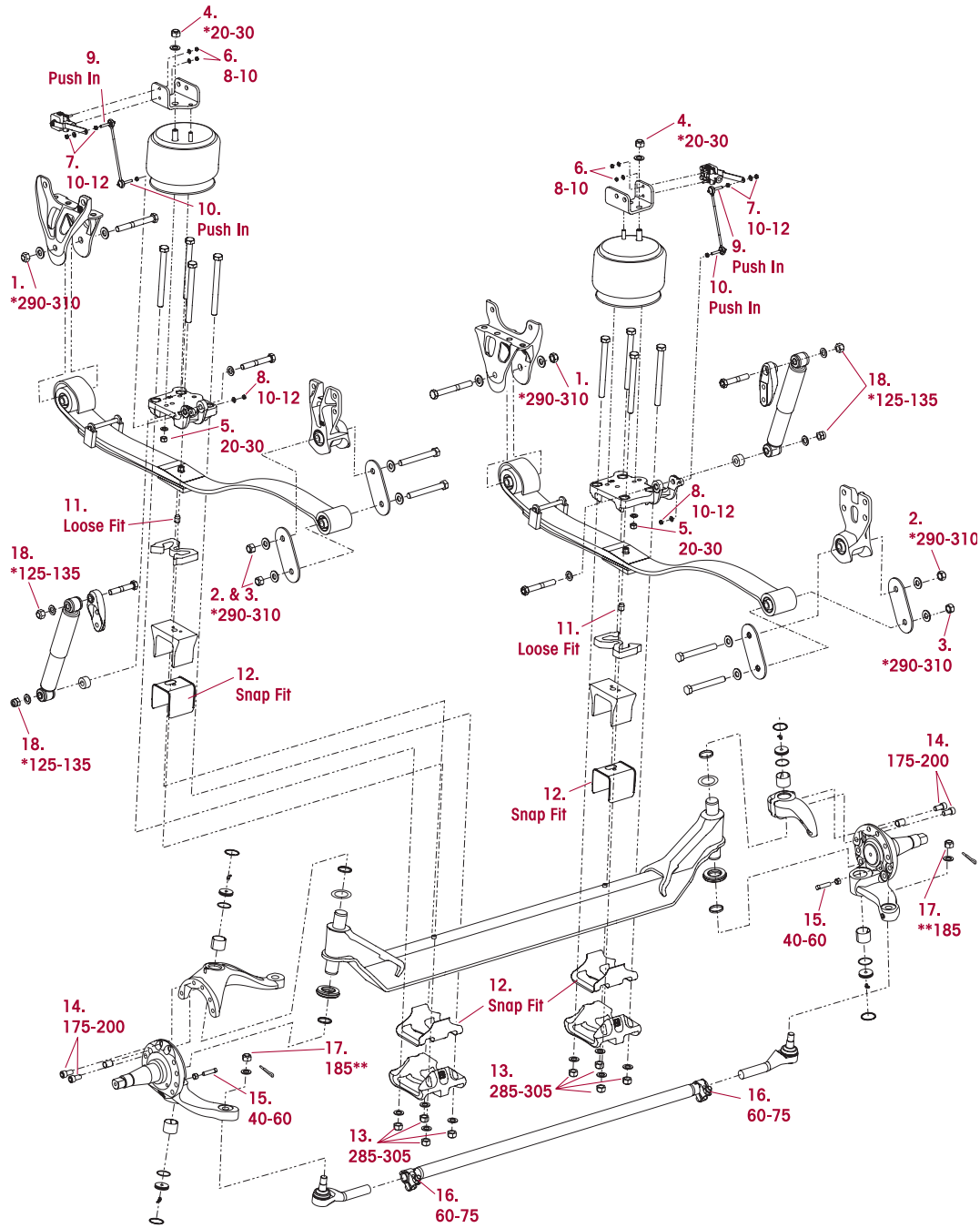
MODEL	AIRTEK		COMFORT AIR	
	RIDE HEIGHT	SHOCK ABSORBER LENGTH	RIDE HEIGHT	SHOCK ABSORBER LENGTH
Blue Bird	From the bottom of the frame to the center of axle	At ride height with a tolerance of ¼"	From the bottom of the frame to the bottom of the main support member.	At ride height with a tolerance of ¼"
Vision 10K	12½"	18 ⅝"	47/8"	22¾"





Hendrickson Recommended
Torque Values Provided In Foot Pounds

Blue Bird All American Buses - 14.6K Capacity





AIRTEK for Blue Bird All American Buses – 14.6K

HENDRICKSON RECOMMENDED TORQUE SPECIFICATIONS				
NO.	COMPONENT	QTY.	SIZE	TORQUE FT./LBS.
1	Front Frame Hanger to Front Leaf Spring Eye	2	M20	*290-310
2	Rear Shackle Bracket to Shackle Plate	2	M20	*290-310
3	Rear Shackle Bracket to Spring Eye	2	M20	*290-310
4	Air Spring to Air Spring Bracket	2	¾"	*20-30
5	Air Spring to Top Pad	2	½"	20-30
6	Height Control Valve to Air Spring Bracket	2	¼"	8-10
7	HCV Linkage to HCV Arm	2	⅝"	10-12
8	HCV Linkage to Top Pad	2	⅝"	10-12
9	HCV Linkage Grommet to HCV Arm	1	Grommet	Push In
10	HCV Linkage Grommet to Top Pad	1	Grommet	Push In
11	Spring Center Aligning Dowel Pin (Flat Floor Bus)	2	¾"	Loose Fit
12	Axle Wrap Liners for Clamp Group	2	Formed	Snap Fit
WARNING: DO NOT ASSEMBLE CLAMP GROUP WITHOUT AXLE WRAP LINERS. FAILURE TO DO SO CAN CAUSE LOSS OF VEHICLE CONTROL, PROPERTY DAMAGE OR PERSONAL INJURY.				
13	Clamp Group Hardware	8	¾"	285-305
WARNING: ENSURE CLAMP GROUP IS ALIGNED PROPERLY PRIOR TO TIGHTENING HARDWARE. FAILURE TO DO SO CAN CAUSE LOSS OF VEHICLE CONTROL, PROPERTY DAMAGE OR PERSONAL INJURY.				
14	Knuckle Attachment Bolt (Socket Head Cap Screw)	4	⅝"	175-200
15	Knuckle / Axle Wheel Stop Bolt	2	⅝" Jam Nut	40-60
16	Tie Rod Tube to Tie Rod Ends	2	⅝"	60-75
17	Tie Rod Ends to Lower Steering Knuckle	2	⅞" Castle Nut	**185
18	Shocks Eye Bolts	2	¾"	*125-135
<p>• All hardware ¼" and greater is Grade 8 with no additional lubrication. Frame mount hardware in most cases are Huck style fasteners supplied by the OEM.</p>				
<p>NOTE:</p> <p>* All hardware information in gray in the matrix denotes recommended torques for fasteners originally supplied by the vehicle manufacturer. If Hendrickson supplied fasteners are used, tighten to Hendrickson torque values, if non Hendrickson fasteners are used, follow torque specifications listed in the vehicle manufacturer's service manual. Hendrickson is not responsible for maintaining vehicle manufacturer's torque values.</p> <p>** Torque to 185 foot lbs., advance nut to next hex face to install cotter pin. Do not back off nut for cotter pin installation.</p>				

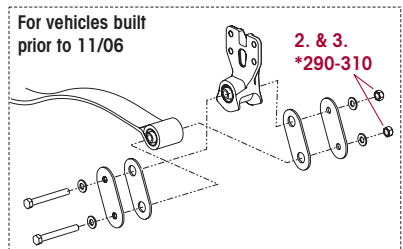
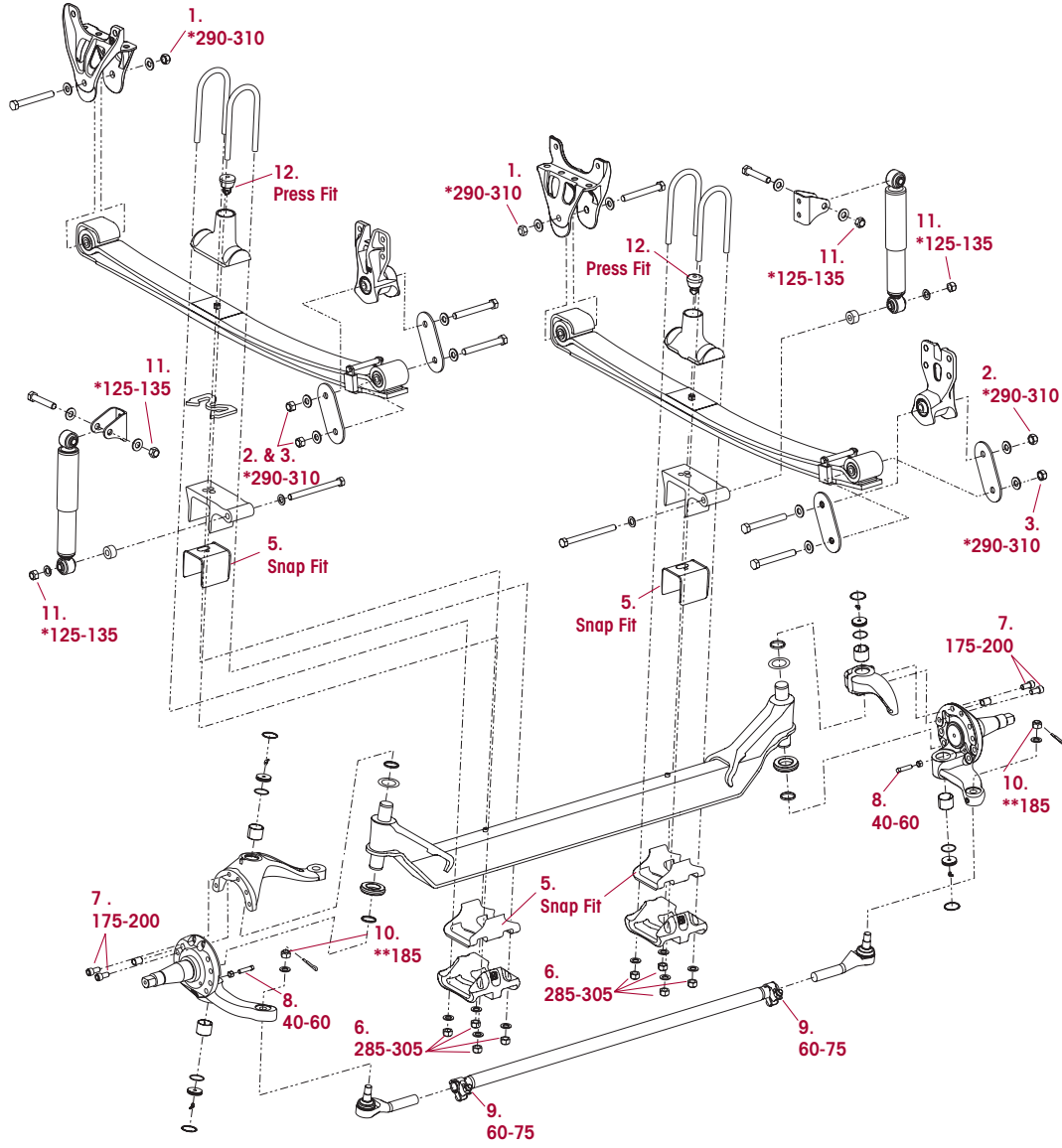
MODEL	AIRTEK		COMFORT AIR	
	RIDE HEIGHT	SHOCK ABSORBER LENGTH	RIDE HEIGHT	SHOCK ABSORBER LENGTH
Blue Bird	From the bottom of the frame to the center of axle	At ride height with a tolerance of ¼"	From the bottom of the frame to the bottom of the main support member.	At ride height with a tolerance of ¼"
All American Front Engine Model	14⅞"	17¼"	4⅞"	22¾"
All American Rearv Engine Model	14⅞"	17 ¹⁵ / ₃₂ "		





Hendrickson Recommended
Torque Values Provided In Foot Pounds

Blue Bird Vision Buses - 8K/10K Capacity





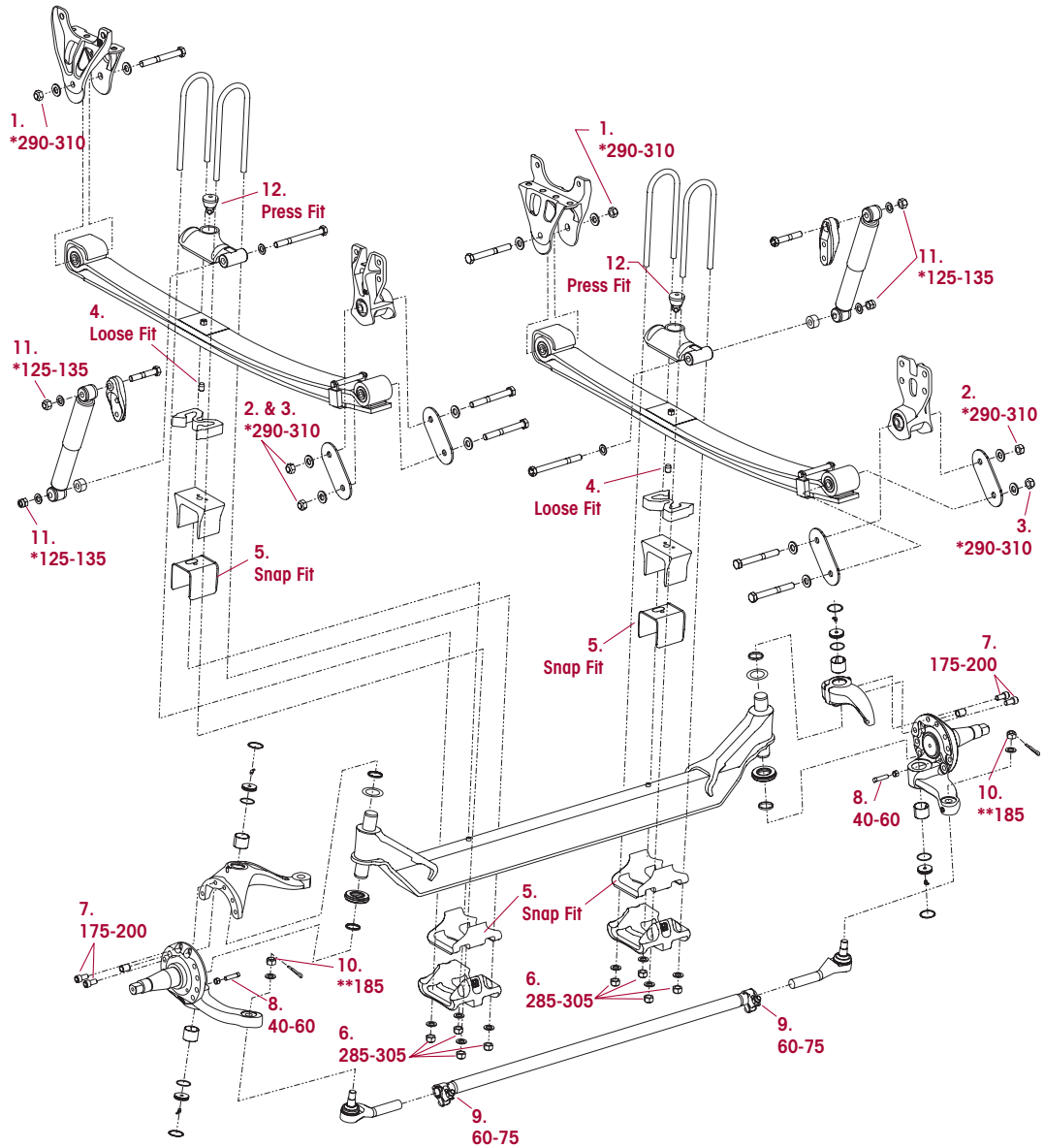
SOFTEK for Blue Bird Vision Buses – 8K/10K

HENDRICKSON RECOMMENDED TORQUE SPECIFICATIONS				
NO.	COMPONENT	QTY.	SIZE	TORQUE FT./LBS.
1	Front Frame Hanger to Front Leaf Spring Eye	2	M20	*290-310
2	Rear Shackle Bracket to Shackle Plate	2	M20	*290-310
3	Rear Shackle Bracket to Spring Eye	2	M20	*290-310
4	Spring Center Aligning Dowel Pin (Flat Floor Bus)	2	¾"	***Loose Fit
5	Axle Wrap Liners for Clamp Group	2	Formed	Snap Fit
WARNING: DO NOT ASSEMBLE CLAMP GROUP WITHOUT AXLE WRAP LINERS. FAILURE TO DO SO CAN CAUSE LOSS OF VEHICLE CONTROL, PROPERTY DAMAGE OR PERSONAL INJURY.				
6	Clamp Group Hardware	8	¾"	285-305
WARNING: ENSURE CLAMP GROUP IS ALIGNED PROPERLY PRIOR TO TIGHTENING HARDWARE. FAILURE TO DO SO CAN CAUSE LOSS OF VEHICLE CONTROL, PROPERTY DAMAGE OR PERSONAL INJURY.				
7	Knuckle Attachment Bolt (Socket Head Cap Screw)	4	⅝"	175-200
8	Knuckle / Axle Wheel Stop Bolt	2	⅝" Jam Nut	40-60
9	Tie Rod Tube to Tie Rod Ends	2	⅝"	60-75
10	Tie Rod Ends to Lower Steering Knuckle	2	⅞" Castle Nut	**185
11	Shocks Eye Bolts	4	¾"	*125-135
12	Rubber Axle Stop	2	—	Press Fit
<ul style="list-style-type: none"> All hardware ¼" and greater is Grade 8 with no additional lubrication. Frame mount hardware in most cases are Huck style fasteners supplied by the OEM. 				
NOTE: <ul style="list-style-type: none"> * All hardware information in gray in the matrix denotes recommended torques for fasteners originally supplied by the vehicle manufacturer. If Hendrickson supplied fasteners are used, tighten to Hendrickson torque values, if non Hendrickson fasteners are used, follow torque specifications listed in the vehicle manufacturer's service manual. Hendrickson is not responsible for maintaining vehicle manufacturer's torque values. ** Torque to 185 foot lbs., advance nut to next hex face to install cotter pin. Do not back off nut for cotter pin installation. *** Denote items not shown on illustration. 				



Hendrickson Recommended
Torque Values Provided In Foot Pounds

Blue Bird All American Buses - 13.2K/14.6K Capacity





SOFTEK for Blue Bird All American Buses – 13.2K/14.6K

HENDRICKSON RECOMMENDED TORQUE SPECIFICATIONS

NO.	COMPONENT	QTY.	SIZE	TORQUE FT./LBS.
1	Front Frame Hanger to Front Leaf Spring Eye	2	M20	*290-310
2	Rear Shackle Bracket to Shackle Plate	2	M20	*290-310
3	Rear Shackle Bracket to Spring Eye	2	M20	*290-310
4	Spring Center Aligning Dowel Pin (Flat Floor Bus)	2	¾"	Loose Fit
5	Axle Wrap Liners for Clamp Group	2	Formed	Snap Fit
WARNING: DO NOT ASSEMBLE CLAMP GROUP WITHOUT AXLE WRAP LINERS. FAILURE TO DO SO CAN CAUSE LOSS OF VEHICLE CONTROL, PROPERTY DAMAGE OR PERSONAL INJURY.				
6	Clamp Group Hardware	8	¾"	285-305
WARNING: ENSURE CLAMP GROUP IS ALIGNED PROPERLY PRIOR TO TIGHTENING HARDWARE. FAILURE TO DO SO CAN CAUSE LOSS OF VEHICLE CONTROL, PROPERTY DAMAGE OR PERSONAL INJURY.				
7	Knuckle Attachment Bolt (Socket Head Cap Screw)	4	⅝"	175-200
8	Knuckle / Axle Wheel Stop Bolt	2	⅝" Jam Nut	40-60
9	Tie Rod Tube to Tie Rod Ends	2	⅝"	60-75
10	Tie Rod Ends to Lower Steering Knuckle	2	⅞" Castle Nut	**185
11	Shocks Eye Bolts	4	¾"	*125-135
12	Rubber Axle Stop	2	—	Press Fit

- All hardware ¼" and greater is Grade 8 with no additional lubrication.
Frame mount hardware in most cases are Huck style fasteners supplied by the OEM.

NOTE:

* All hardware information in gray in the matrix denotes recommended torques for fasteners originally supplied by the vehicle manufacturer. If Hendrickson supplied fasteners are used, tighten to Hendrickson torque values, if non Hendrickson fasteners are used, follow torque specifications listed in the vehicle manufacturer's service manual. Hendrickson is not responsible for maintaining vehicle manufacturer's torque values.

** Torque to 185 foot lbs., advance nut to next hex face to install cotter pin. Do not back off nut for cotter pin installation.



AIRTEK for Blue Bird Buses

FRONT AIR MODULE SUSPENSION ALIGNMENT SPECIFICATION

CAMBER ¹	DESIGN SPECIFICATION	RANGE	
		MINIMUM	MAXIMUM
LEFT	0.00° ± 1.0°	-1.0°	+1.0°
RIGHT	- 0.25° ± 1.0°	-1.25°	+0.75°
CROSS	Max 2.0°	—	—

CAMBER NOTES:

¹ The camber angle is not adjustable. Do not bend axle or otherwise try to adjust camber. If found out of specification, notify Hendrickson Tech Services for further information.

CASTER ^{1,2}	DESIGN SPECIFICATION	RANGE			
		10K		14.6K	
		MINIMUM	MAXIMUM	MINIMUM	MAXIMUM
LEFT	4.1° ± 1°	+3.1°	+5.1°	+3.1°	+5.1°
RIGHT	4.1° ± 1°	+3.1°	+5.1°	+3.1°	+5.1°
CROSS ³	Max 1.0°	—	—	—	—

CASTER NOTES:

- ¹ Caster is determined with the vehicle at specified ride height for air suspension or at rated load for mechanical suspension systems. It is critical that the vehicle front and rear ride height is within specifications prior to performing a caster measurement or adjustment. See Hendrickson ride height specifications and procedure.
- ² In most cases actual vehicle caster is defined with the frame rails at zero slope. Refer to the vehicle manufacturer's specifications for correct frame rail slope. (Both the alignment surface and the vehicle's frame rails should be level during execution of alignment procedures). For vehicles with a positive frame rake (higher in rear) add the frame slope (in degrees) to the caster reading to determine true vehicle caster.
- ³ **The cross caster angle is not adjustable** – Do not bend axle or otherwise try to adjust cross caster. If found out of specifications notify Hendrickson Tech Services for further information. Changes to caster can be attained by using caster shims as provided by the vehicle manufacturer or chassis and body manufacturer. Caster shims must match, side to side, to reduce uneven loading to the suspension components. **The use of two different angle caster shims will not correct cross caster.**
- ⁴ **Example of caster adjustment:** 2.5° RH/3° LH, would require one, 1.0 shim on each side to increase caster and achieve 3.5° RH/4.0° LH, which is in specification. Do not attempt to use uneven shims.

Hendrickson recommends following TMC² practices:

	DESIGN SPECIFICATION ¹	RANGE	
		MINIMUM	MAXIMUM
TOTAL TOE²	1/16" ± 1/32" (0.06" ± 0.03")	1/32" (0.03")	3/32" (0.09")

TOE-IN NOTES:

- ¹ Toe-in is to be set and adjusted in the normal vehicle unladed configuration. Actual vehicle curb weight on the ground. Toe should be checked at the tires front and rear tread center, at a distance above ground equal to the tire's rolling radius.
- ² In most instances total toe is set by the vehicle manufacturer or body builder. Consult the vehicle manufacturer for specifications.



SOFTEK for Blue Bird Buses

FRONT AIR MODULE SUSPENSION ALIGNMENT SPECIFICATION

CAMBER ¹	DESIGN SPECIFICATION	RANGE	
		MINIMUM	MAXIMUM
LEFT	0.00° ± 1.0°	-1.0°	+1.0°
RIGHT	- 0.25° ± 1.0°	-1.25°	+0.75°
CROSS	Max 2.0°	—	—

CAMBER NOTES:

- ¹ The camber angle is not adjustable. Do not bend axle or otherwise try to adjust camber. If found out of specification, notify Hendrickson Tech Services for further information.

CASTER ^{1,2}	DESIGN SPECIFICATION	RANGE			
		8K/10K		13.2K/14.6K	
		MINIMUM	MAXIMUM	MINIMUM	MAXIMUM
LEFT	4.5° ± 1°	+3.5°	+5.5°	+3.5°	+5.5°
RIGHT	4.5° ± 1°	+3.5°	+5.5°	+3.5°	+5.5°
CROSS ³	Max 1.0°	—	—	—	—

CASTER NOTES:

- ¹ Caster is determined with the vehicle at specified ride height for air suspension or at rated load for mechanical suspension systems. It is critical that the vehicle front and rear ride height is within specifications prior to performing a caster measurement or adjustment. See Hendrickson ride height specifications and procedure.
- ² In most cases actual vehicle caster is defined with the frame rails at zero slope. Refer to the vehicle manufacturer's specifications for correct frame rail slope. (Both the alignment surface and the vehicle's frame rails should be level during execution of alignment procedures). For vehicles with a positive frame rake (higher in rear) add the frame slope (in degrees) to the caster reading to determine true vehicle caster.
- ³ **The Cross caster angle is not adjustable** – Do not bend axle or otherwise try to adjust cross caster. If found out of specifications notify Hendrickson Tech Services for further information. Changes to caster can be attained by using caster shims as provided by the vehicle manufacturer or chassis and body manufacturer. Caster shims must match, side to side, to reduce uneven loading to the suspension components. **The use of two different angle caster shims will not correct cross caster.**
- ⁴ **Example of caster adjustment:** 2.5° RH/3° LH, would require one, 1.0 shim on each side to increase caster and achieve 3.50° RH/4.00° LH, which is in specification. Do not attempt to use uneven shims.

Hendrickson recommends following TMC² practices:

	DESIGN SPECIFICATION ¹	RANGE	
		MINIMUM	MAXIMUM
TOTAL TOE ²	1/16" ± 1/32" (0.06" ± 0.03")	1/32" (0.03")	3/32" (0.09")

TOE-IN NOTES:

- ¹ Toe-in is to be set and adjusted in the normal vehicle unladed configuration. Actual vehicle curb weight on the ground. Toe should be checked at the tires front and rear tread center, at a distance above ground equal to the tire's rolling radius.
- ² In most instances total toe is set by the vehicle manufacturer or body builder. Consult the vehicle manufacturer for specifications.

Reference Material

This technical publication covers Hendrickson Truck Suspension's recommended procedures for our parts/products. Other components play a major role in overall performance and Hendrickson recommends you follow the specific vehicle manufacturer's recommendation for care and maintenance. Some recommended procedures have been developed by The Technology & Maintenance Council (TMC) and Hendrickson supports these recommendations. We have compiled a list of these below.

TMC

To obtain copies of the following RP's, video's, or charts, contact TMC at:

TMC/ATA
2200 Mill Road
Alexandria, VA 22314

Phone: 703-838-1763
website: tmc.truckline.com
online ordering: www.truckline.com/store

Important References

TMC RP 214B	Tire/Wheel End Balance and Runout
TMC RP 216	Radial Tire Conditions Analysis Guide
TMC RP 219A	Radial Tire Wear Conditions and Causes
TMC RP 222A	User's Guide To Wheels and Rims
TMC RP 230	Tire Test Procedures for Tread wear, Serviceability, and Fuel Economy
TMC RP 514	Pre-Alignment Inspection
TMC RP 618	Wheel Bearing Adjustment Procedure
TMC RP 620B	Front End Alignment Steering Geometry
TMC RP 708A	Trailer Axle Alignment
TMC RP 642	Guidelines For Total Vehicle Alignment
TMC RP 644	Wheel End Conditions Analysis Guide
TMC RP 645	Tie Rod End Inspection and Maintenance Procedure

Video's

TMC T0326	Wheel End Maintenance
TMC T0372	Tire Pre-Trip Inspection Guidelines

Other


TMC T0400	Wheel bearing Adjustment Procedure Wall Chart
-----------	---

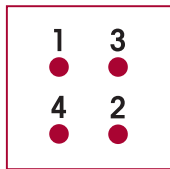


Technical Procedure Publication Quiz

- 1) What three items have the greatest influence on tire wear?
 - a) Toe
 - b) Air Pressure
 - c) Camber
 - d) Thrust Angle
- 2) Caster may be increased or decreased using shims or wedges.
True or False
- 3) Cross caster may be changed using shims or wedges.
True or False
- 4) You may bend a STEERTEK axle to correct for improper camber settings.
True or False
- 5) In an unladen vehicle the correct toe setting for the STEERTEK axle is?
 - a) 0 to negative $\frac{1}{8}$ "
 - b) 0 to negative $\frac{1}{16}$ "
 - c) 0 to positive $\frac{1}{32}$ "
 - d) $\frac{1}{16}$ " \pm $\frac{1}{32}$ "
- 6) When reducing wheel cut on the STEERTEK axle it is necessary to check the steering gear box poppets.
True or False
- 7) The torque requirement for the front and rear spring hanger eye bolts are the same.
True or False
- 8) When servicing the clamp group a technician should always replace the following items.
 - a) Hex bolts/U-bolts (Grade 8) and nylon locknuts (Grade C).
 - b) Bottom axle wrap liner.
 - c) Upper axle wrap liner, if removed.
 - d) All of the above.
- 9) What is the clamp group final torque?
 - a) 500-550 foot pounds.
 - b) 290-310 in. pounds.
 - c) 285-305 foot pounds.
 - d) 240-275 foot pounds.



10) What is the  torque sequence for the clamp group? See Figure below.



- a) 1,3,2,4
- b) 1,4,2,3
- c) 1,2,3,4
- d) The torque sequence does not matter.

11) For a vehicle equipped with a STEERTEK axle it is an acceptable practice to tow using a tow chain wrapped around the axle.

True or False.

12) The front leaf spring eye bushing is non serviceable

True or False

13) To remove the STEERTEK knuckle you must.

- a) Drive the kingpin out of the axle bore.
- b) Remove the locking pins before driving the kingpin out.
- c) Remove the two 5/8" socket head cap screws and separate the knuckle assembly.
- d) None of the above.

14) What is the maximum allowable specification for lateral movement of the steering knuckle?

- a) 0.001"
- b) 0.075"
- c) 0.030"
- d) 0.015"



15) When the AIRTEK ride height is checked, it is not necessary to cycle the leveling valve before check the ride height.

True or False

16) Worn kingpins are easily removed and replaced.

True or False

17) The lower shock eye bolt mounting torque per the vehicle manufacturer is:

- a)  125-135 foot pounds.
- b)  225-255 foot pounds.
- c) not critical
- d) none of the above

18) Although the AIRTEK/SOFTEK is low maintenance, it is recommended to do a visual inspection on the axle and suspension every _____ miles.

- a) 100,000 or 1 year
- b) 25,000 or 6 months
- c) Never



- 19) When replacing the rear spring $\frac{3}{4}$ " length hanger bolts, the new bolts should be installed:
- a) From the outboard side to inboard side for AIRTEK 10K and SOFTEK 8K/10K
 - b) It does not matter what direction the bolts are facing
 - c) From the inboard side to outboard side for AIRTEK 14.6K and SOFTEK 13.2K/14.6K
 - d) Both a and c
- 20) The STEERTEK axle combined with the clamp group and stiff front spring limb help to make the AIRTEK torsionally rigid and reduce body roll.
True or False
- 21) How many grease points are there on the STEERTEK axle?
- a) 2
 - b) 6
 - c) 8
 - d) None
- 22) It is acceptable to replace a failed shock absorber with any brand that will fit.
True or False
- 23) A shock that is misting is classified as a leaking shock and should be replaced immediately.
True or False
- 24) Prior to performing a total vehicle alignment the following components must be inspected.
- a) Front and rear spring mounts
 - b) Steer axle tires
 - c) Ride height
 - d) All of the above
- 25) Wheel bearing adjustment has no impact on tire wear.
True or False
- 26) When the clamp group is disassembled the use of a cutting torch is acceptable to help remove seized bolts and nuts.
True or False
- 27) Prior to steering knuckle re-assembly it is critical that residual Loctite be removed and re-applied from the upper kingpin connection.
True or False
- 28) AIRTEK is available exclusively with the STEERTEK axle.
True or False
- 29) To heat test a shock absorber you should drive a vehicle at moderate speeds for fifteen minutes.
True or False



- 30) If the kingpin bushing is worn, then both bushings on that knuckle need to be replaced.
True or False
- 31) The unique packaging of the steering knuckle will allow up to _____ degrees of wheel cut on the STEERTEK axle.
 - a) Maximum of 50°
 - b) 32°
 - c) 87°
 - d) None of the above
- 32) A pre-alignment inspection reveals a tie rod end is worn out of specification. What is the correct action needed to complete the alignment.
 - a) Fill the tie rod with grease to absorb excessive play.
 - b) Replace the tie rod and reset toe before alignment.
 - c) Perform alignment and then replace tie rod end and reset toe.
 - d) Align vehicle and do not repair tie rod end.
- 33) The seal on the thrust bearings are installed facing down.
 - a) True
 - b) False
 - c) Doesn't matter
- 34) When servicing tie rod ends it is not necessary to have the part number located on the tie rod tube to order tie rod service kits.
True or False

CERTIFICATE

Hendrickson will provide a personalized AIRTEK/SOFTEK Technical Procedure Quiz Achievement Certificate to candidates scoring 80% or higher on the test. Simply complete the test and fill in the enclosed answer sheet or on a separate sheet with the return address, name, phone number, and company name as it will appear on the award to:

Hendrickson
 ATTN: Truck Marketing Test Quiz Assessment
 800 S. Frontage Road
 Woodridge, Illinois 60517



www.hendrickson-intl.com



Truck Suspension Systems
800 South Frontage Road
Woodridge, IL 60517-4904 USA

630.910.2800
Fax 630.910.2899

