

Commercial Rear-Entry Guide

2-5-24



Commercial Rear-Entry

V3

VA

The BraunAbility Commercial Rear-Entry built on the Chrysler Voyager is the culmination of over 50 years experience in wheelchair accessibility in commercial and public transportation. The rear-entry conversion is a passenger-friendly as well as a cost-efficient mobility solution for many commercial transportation providers.

The Chrysler Commercial Rear-Entry has multiple seating options available to accommodate passengers and wheelchair users. Depending on the options you select, you'll have the flexibility in seating and wheelchair configurations to meet all your customers' needs. Two floorplans available - V3 long floor and VA short floor.

Safety has always been a top priority at BraunAbility. The Chrysler Commercial Rear-Entry has been crash tested and certified to meet or exceed all applicable requirements of the Federal Motor Vehicle Safety Standards (FMVSS) and is backed by our three-year limited warranty.

- **Seating options: Up to 7 passengers*, configurations up to 2 wheelchair positions**
- **Radius floor provides rounded floor for easier transition for wheelchair passenger to front**
- **New OEM Tier 1 ramp latching system minimizing movement and ramp noise**
- **Weather Tech mats provides enhanced floor protection and sound deadening benefits**

* With optional 2nd row 3-passenger bench seat and optional 3rd row 2-passenger folding bench seat

Standard Features

- 2022-2024 Chrysler Voyager
- FTA Buy America compliant
- ADA, FMVSS and CMVSS compliant
- Meets/exceeds Altoona test requirements
- CARB compliant
- 56" rear door opening
- Lowered floor section, aft of 1st row seats
- 34" wide manual ramp with 1,000 lb capacity
- Remount OEM quad seats - Flip & Fold **V3**
- ADA commercial flooring
- Q'STRAIT wheelchair securement tie-downs - QRT MAX Slide-n-Click
- Transmission interlock
- ADA ramp lighting
- Emergency exit release for rear hatch
- Back-up alarm

Optional Features

- Simple Stow™ Ramp **VA**
- 2nd row 3-passenger OEM bench remount **VA**
- 2nd row 3-passenger aftermarket bench **VA**
- 3rd row 2-passenger foldaway seat
- Vinyl cover kits for OEM seats
- DOT kit
- Additional wheelchair securement belts: Q'STRAIT QRT Deluxe, QRT MAX, QRT 360
- Additional set of lap and shoulder belts



V3 Shown



Commercial Rear-Entry Features

V3

VA

BraunAbility Commercial Rear-Entry built on: ▶

2023-2024 Chrysler Voyager LX

2023-2024 Chrysler Pacifica 27W

2023-2024 Chrysler Grand Caravan (Canada)

See back of this guide for vehicle requirements.

- ADA, FMVSS, CMVSS Compliant
- FTA Buy America Compliant Option Available
- Meets or Exceeds Altoona Test Requirements
- CARB Compliant
- ADA Compliant Interlock
- ADA Compliant Ramp & Door Entrance Lighting



◀ Manual Door ▶

ADA-compliant manual rear door with 56" vertical opening.

◀ Lowered Radius Floor ▶

The rear floor is lowered from the rear door to just behind the front seats and provides a choice of two wheelchair positions. The radius floor provides for easier transition for wheelchair passengers over axle. Available in two floor lengths - V3 Long and VA short floors.

◀ Manual Folding Ramp ▶

The standard low-angle 34" wide aluminum foldout ramp (1,000 lb capacity) makes it easy to load and unload wheelchair users. Optional Simple Stow™ ramp available on VA, see options page.

◀ Ramp Latching System ▶

This Tier 1 component minimizes metal-on-metal movement and ramp noise.



◀ 2nd Row OEM Remount Flip & Fold Seating V3 ▶

The Voyager Commercial RE comes standard with 2nd row OEM remounted (quad) flip & fold seats, which when folded up provides for 2 wheelchair positions. Center bench seat options are available VA, which only allow for 1 wheelchair position in the rear. See options page for other seating options.



◀ Custom Sculpted Mats ▶

The heavy-duty custom fitted Weather Tech mats offer enhanced floor protection and sound deadening benefits.



Q'STRAIT Wheelchair/Occupant Securement System

One standard belt system included.

◀ ADA-Compliant Ramp and Door Entrance Lighting ▶

Emergency Rear Hatch Release ▶



Commercial Rear-Entry Dimensions

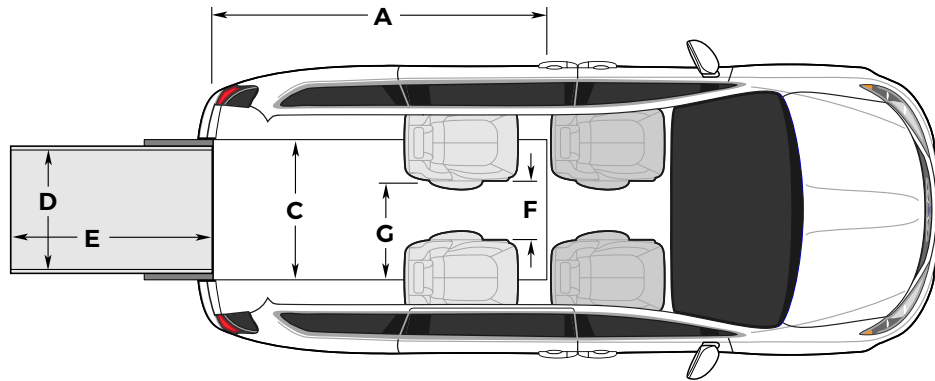

V3

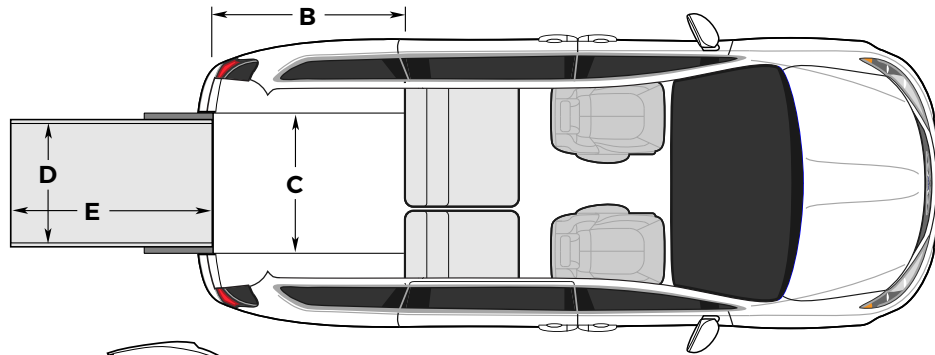

VA

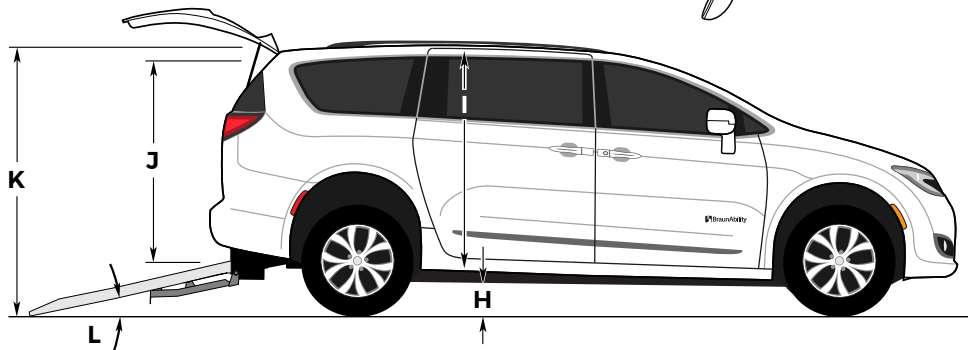

Ramp Capacity
1,000 lbs.

All dimensions are for reference only.

		Foldout Ramp V3 & VA	Simple Stow™ Ramp Option - VA
Lowered floor length V3	A	98"	-
Lowered floor length VA (behind 2nd row bench)	B	54.625"	59.75"
Lowered floor width	C	34.25"	34"
Ramp width (usable clear opening)	D	34"	33"
Ramp length	E	60"	51.125"
OEM mid-row seats V3 (both unfolded)	F	15.25"	-
OEM mid-row seats V3 (one folded up)	G	23.5"	-
Ground clearance at muffler (lowest point - loaded)	H	5"	5"
2nd row wheelchair location interior height V3	I	56"	-
Entrance height	J	56"	56"
Overall vehicle height (hatch closed - unloaded)	K	75"	75"
Ramp angle*	L	10°	12°

Due to manufacturing tolerances both with the OEM vehicle and the conversion components, all dimensions may vary slightly from those shown.

* Ramp angle may vary based on chassis trim level and other environmental factors - measured with a 250 lb approximated wheelchair passenger load at the center of the ramp

Commercial Rear-Entry Options

V3

VA



◀ VA

Simple Stow™ Ramp



Allows easy access to luggage and cargo when the ramp is not in use. Ramp stows flat on floor when not in use. Stows vertically when a wheelchair passenger is secured in vehicle. VA only.



◀ VA

2nd Row OEM 3-Passenger Bench Seat - with Floor Filler



Makes center wheelchair position unusable. Seat backs fold down for access to rear wheelchair position tie-downs.



◀ VA

2nd Row Freedman 3-Passenger Bench Seat - with Floor Filler



Makes center wheelchair position unusable. Seat backs fold down for access to rear wheelchair position tie-downs.



◀ 512087K

3rd Row Freedman 2-Passenger Folding Bench Seat



Seat folds up when not in use to make room for wheelchair location.



510038K

Vinyl Seat Covers

1st row driver and passenger seats - black.

512246K

Vinyl Seat Covers

For V3 2nd row Flip & Fold seats - black.

513190K

Cloth Seat Covers

For V3 2nd row Flip & Fold seats - black.

510043K

Vinyl Seat Covers

For VA 2nd row OEM 3-passenger bench seat.

Commercial Rear-Entry Options

V3

VA



- ◀ **VPM20011N DOT Package**
(5# Fire Extinguisher, 10 First Aid Kit, Triangle Flare Kit, Body Fluid Kit)

512615K CSA-D409 Package (for Canadian Use)



Q'STRAIT

- ◀ **512611K Extra Retractors and Belts - QRT MAX - 4 Retractors, Lap & Shoulder Belt**

512205K Swap Standard QRT MAX for QRT Deluxe - 4 Retractors, Lap & Shoulder Belt

512612K Extra Retractors and Belts - QRT Deluxe - 4 Retractors, Lap & Shoulder Belt

512206K Swap Standard QRT MAX for QRT 360 - 4 Retractors, Lap & Shoulder Belt

512613K Extra Retractors and Belts - QRT 360 - 4 Retractors, Lap & Shoulder Belt

512210K QRT Electric Max Retractors

512211K QRT Electric Deluxe Retractors

512212K QRT Electric 360 Retractors

510205K Inflatable Compact Spare Tire - Mounted in OEM Sidewall Storage Location

512245K High Conspicuity Ramp Tape Kit

- ◀ **512767 OEM Running Board Kit - Black Only**



Vehicle Information

V3

VA

2023-2024 Voyager LX. 2023-2024 Pacifica 27W. 2023-2024 Grand Caravan (Canada).
No Safety Sphere.

Before ordering or drop-shipping a vehicle, we strongly recommend contacting BraunAbility® for guidance in deriving payload capacities and selecting equipment and seating options before you purchase the vehicle.

BraunAbility will only convert 2023-2024 Chrysler Voyager LX, 2023-2024 Chrysler Pacifica 27W and 2023-2024 Chrysler Grand Caravan (Canada) with 50,000 or less miles. Customer supplied chassis will incur a charge (see pricing page). Vehicles must be in sound condition and must never have been involved in an accident. All vehicles are inspected and subject to acceptance/rejection upon arrival at the BraunAbility plant.

BraunAbility Drop Ship Code T7305

Safety has always been a top priority at BraunAbility. The Chrysler Commercial Rear-Entry has been crash tested and certified to meet or exceed all applicable requirements of the Federal Motor Vehicle Safety Standards (FMVSS) and is backed by our 3 year/36,000 mile limited and 5 year/unlimited mile rust-through metal protection on every vehicle that leaves the factory. Add to this the original Chrysler warranty for unconverted parts and a nationwide dealer network, and you can rest assured BraunAbility will be there to support you no matter where your travels take you.

Wheelchair securement belts and track are by **Q'STRAIT**.



braunability.com

800.488.0359

ISO 9001:2015

631 West 11th Street, Winamac, IN 46996, USA

