

## Chassis Frame Overview

The Blue Bird Vision's chassis frame consists of two main C-channel rails which run the entire length of the bus, and several different kinds of cross members located at strategic intervals. This ladder-like structure forms the backbone of the vehicle's chassis. The exact number and placement of cross members varies according to body length and locations of doors and other equipment. Front and rear bumper brackets are mounted directly to the ends of the main frame rails. Tow hooks are also mounted at both ends.

The Vision's body assembly is mounted to the chassis's main frame rails by a system of bolted-on clamps, angled brackets, and rubber and spring isolators. Square rubber pads are clamped at floor-to chassis contact points to help minimize vibration and metal fatigue.

## Maintenance Overview

The Vision's frame was developed under stringent accelerated wear and fatigue testing to ensure robust performance and long life. The major structural components of the frame should not require servicing under normal conditions. However, they should be included in routine visual inspections. The body-to-chassis attachment points should be regularly inspected and tightened.

- Inspect frame rails and cross members for signs of cracks, vibration, or loose fittings any time work is being performed under the bus, at regular inspection intervals of 3 months. Watch for telltale signs of possible structural damage, such as cracked paint, vibration residue around joints and fasteners, and/or corrosion.
- Check for deteriorated, shifting or missing tie-down pads. Replace if needed.
- After the first 1000 miles of operation and at 3 month intervals thereafter, tighten all body tie-down points to the torque value appropriate for each type of tie-downs.

## Huck Fasteners

Frame members and many related components are assembled using special Huck Spin fasteners which provide extremely secure and fatigue-resistant permanent joints. A Huck fastener consists of a threaded pin onto which a collar is permanently swaged under high mechanical pressure.

Huck Spin fasteners require special tools for assembly and should not be considered serviceable items under normal circumstances. However, damage due to collision or extreme operating conditions may require replacement of a part which is assembled with Huck fasteners. If the need for such a repair is determined, contact your Blue Bird Distributor or Blue Bird Customer Service for consultation.

# Chassis Frame

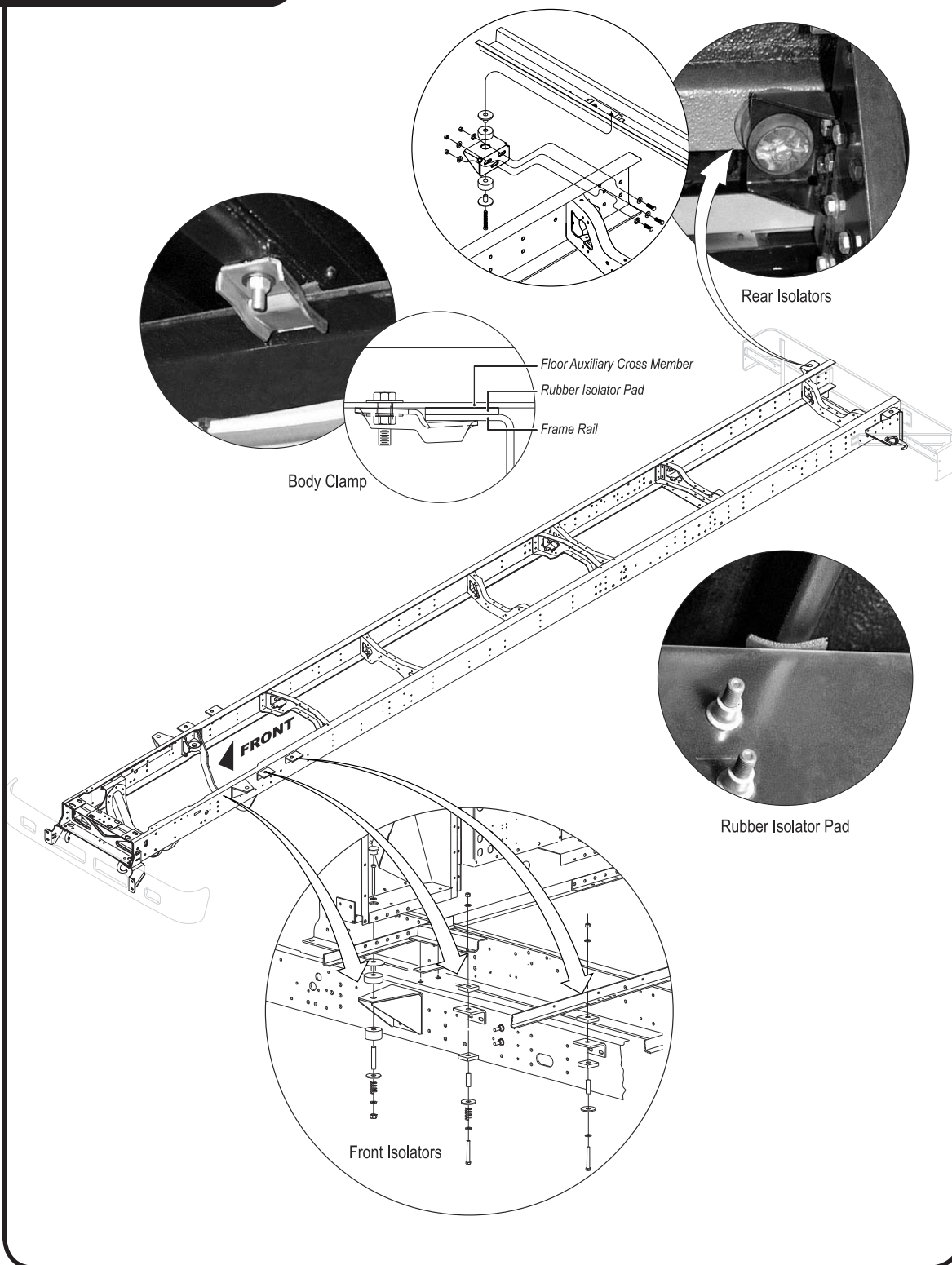



**Removal/Replacement**

Although normally meant to be a permanent attachment, a Huck fastener may be successfully removed as follows:

1. Inspect the joint thoroughly and take all safety measures and precautions to ensure that all components, which are affected on both sides of the fastener, are fully supported.
2. Cut along the length of one side of the collar using one of these methods:
  - Drilling: Using a drill bit slightly larger than the nut's wall thickness, drill along the length of the collar, parallel to and against the side of the pin.
  - Grinding: Using a grinding/cutting wheel on a high-speed rotary tool, cut along the length of the collar.
  - Chiseling: Using an air hammer equipped with a chisel blade, cut the collar on one side of its length.
  - Torch: Using an oxy-acetylene cutting torch, cut the collar along one side of its length.

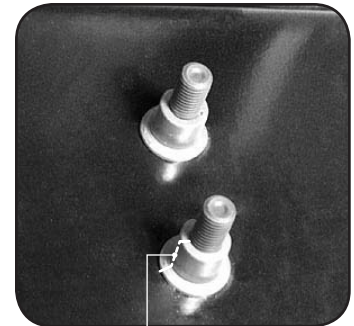

*Huck Fastener  
Removal requires cutting along length of swaged collar.*

**WARNING** Whenever using a cutting torch to cut a Huck fastener collar, ensure that the torch does not also damage the mounted brackets or parts. If the fastener to be cut is in proximity to any part that may be damaged by the conducted heat of the cutting operation, use another method to remove the collar.

3. After drilling, use a cold chisel to break the collar or to spread it enough to allow removal. Remove the threaded bolt, using a hammer to tap it out if necessary.
4. Discard all parts of the removed Huck fastener. Do not attempt to re-use the bolt. Removed Huck fasteners must be replaced with appropriately-sized grade 8 bolts lock nuts, using hardened washers on both sides.

huckspin				grade 8 bolt, washers, nut						
Blue Bird Part Number	Huck Number	Nominal Length	Grip Range	Blue Bird Part Number	Nominal Length	Thread	Flat Washer	Nut	Locking Nut	Material Thickness
1636943	10	2.25	0.43–0.90	0803239	1.5	½–13	1003045	½–20	0850800	0.25–0.75
1636943	10	2.25	0.43–0.90	0803148	1.75	½–13				0.50–1.00
1636950	16	2.60	0.85–1.25	0803148	1.75	½–13				0.50–1.00
1636943	10	2.25	0.43–0.90	0959542	1.75	½–20				0.50–1.00
1636950	16	2.60	0.85–1.25	0959452	1.75	½–20				0.50–1.00
1636950	16	2.60	0.85–1.25	0803205	1.75	½–13				0.75–1.25
1746817	20	2.85	1.09–1.50	0803205	2.00	½–13				0.75–1.25

## Body Tie-down Clamps and Angles

At most places where a joint between two adjacent body floor sections crosses the main frame rails, body tie-down clamps secure the body to the main frame rails. The clamps bolt to the floor joint body bar angles and, when tightened, clamp against the inboard edge of the frame rail's upper flange.

Wherever equipment mounted between the main frame rails prevents the use of a body tie-down clamp (for example, in the area of the rear mounted fuel tank), body tie-down angles are bolted to the outboard side of the frame rail and to the floor joint body bars.

### Inspection/Adjustment

All body tie-down clamps and angles should be checked for proper tightness after the first 1000 miles of operation and every three months thereafter. Tighten to 37–41 ft. lbs. (50–56 Nm).

## Rubber Mounting Pads

At each location where an Auxiliary Floor Cross Member crosses the main frame rails, a small square rubber pad is clamped between the body floor and the chassis rail. These pads help minimize vibration and fatigue.

### Inspection/Replacement

Loss of the rubber pads can result in an airspace and subsequent loosening of the associated tie-down clamp(s) or angle(s). Wherever the rubber pads have deteriorated or fallen out, they should be replaced as follows:

1. Prepare the bus for working underneath according to the precautions in Chapter 1.
2. Loosen the tie-down clamp bolt(s) near the damaged or missing rubber pad.
3. Using an appropriate jack positioned on the Auxiliary Cross Member, raise the body floor only sufficiently to replace the pad.

**CAUTION** *Raise the body bar with the jack only the minimum distance required, to insert the new pad and its plastic push in retainer. Do not overstress the body. If undue resistance is encountered, loosen more body tie-down points in the vicinity of the repair.*

4. After replacing the pad, retighten all body clamps that were loosened to 37–41 ft. lbs. (50–56 Nm).



## Body Mount Isolators

To accommodate the greater expansion and movement stresses at the far ends of the body mount system, the body tie-down points in these areas are mounted to isolators which minimize vibration, and help prevent fatigue.

On each side of the bus, the front end of the body and the bottom of the firewall box are attached to the frame rails by three different arrangements of isolators using rubber disks, rubber blocks, and coil springs.

The rearmost body tie-down points on each side of the frame are mounted on rubber disc isolators. Under normal operating conditions, these isolators should not need replacement, although severe operating conditions may shorten their life.

## Inspection/Adjustment

The isolator mounts should be visually inspected for damage and checked for tightness at the same times as the tie-down clamps and angles (after the first 1000 miles of operation and every three months thereafter).

## Rear Rubber Isolator Replacement

The top half of the rubber isolator is molded to a steel sleeve, which passes through the mounting bracket. Therefore, removal is simplified by unbolting the isolator mounting bracket from the frame rail: The frame side of the mounting bracket is slotted to allow proper seating of the isolator against the floor before tightening the bracket to the frame.

1. Loosen the 3 bolts, which fasten the isolator bracket to the chassis frame.
2. Remove the bolt, which passes through the isolator.
3. Replace the isolator and loosely assemble the parts back in place. Torque the isolator bolt to 54–58 ft. lbs. (73.2–78.6 Nm).
4. Torque the bracket bolts to 70–80 ft. lbs. (95–108.5 Nm).

## Front Floor Mount Rubber Block Isolators

Each of the two front floor tie-down isolator mounts on each side of the frame use two .66" thick x 2.5" square rubber blocks above and below their frame mount angle bracket. These mounts should be tightened to 52-56 ft lbs (70.5-75.9 Nm).

## Firewall Box Mount Rubber Disc Isolators

The frontmost tie-down isolator mounts, one on each side of the frame, use rubber disc isolators, and attach the floor of the firewall box to large gusseted brackets on the frame rails. On these mounts, the nuts are on the underside, and the bolt heads are accessible through access plugs on the floor of the firewall box, inside the bus. Tighten these mounts to 52-56 ft lbs (70.5-75.9 Nm).

## Front Body Tie-Downs

62

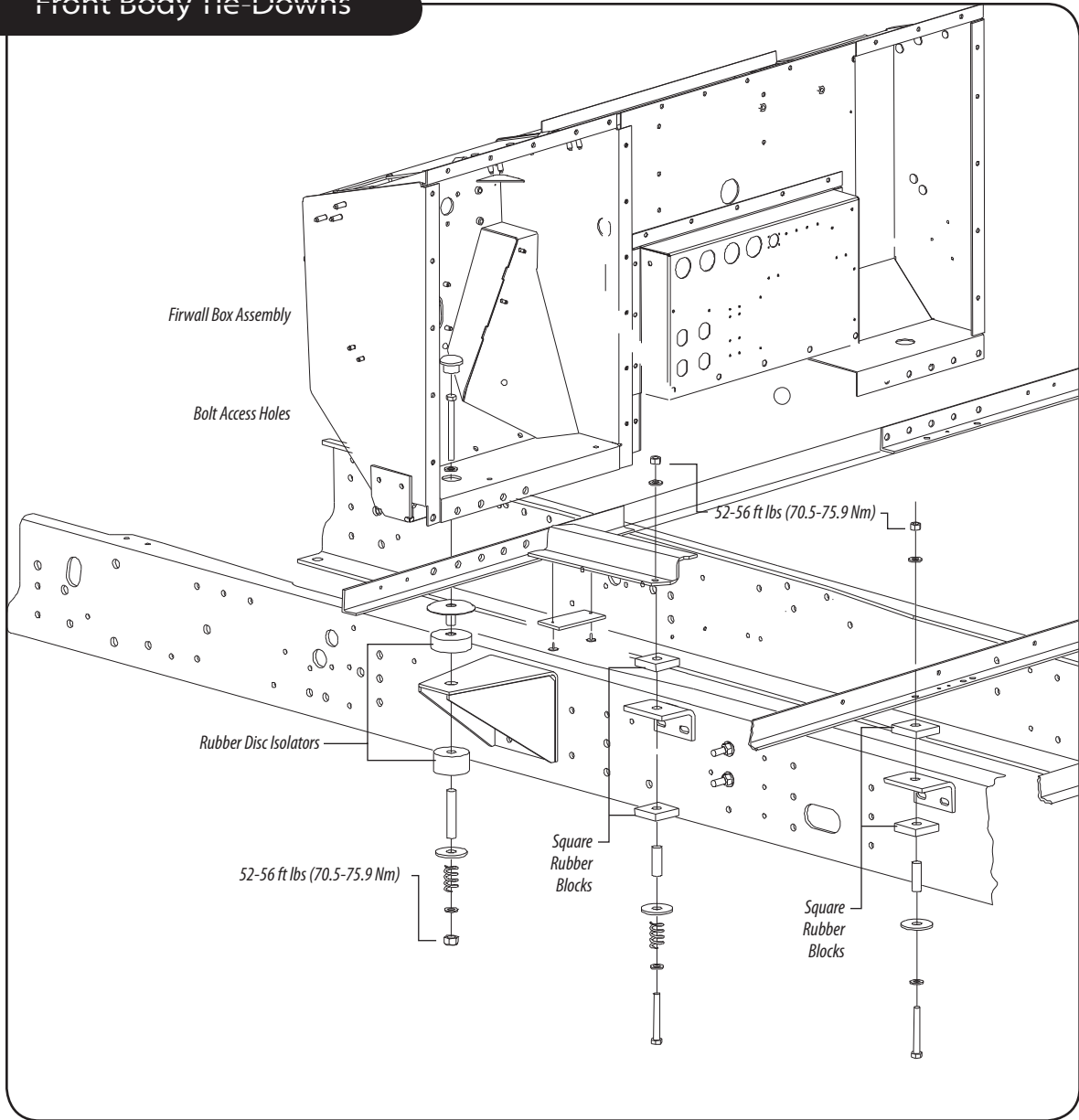

0073783F